

Advanced Optical Communications
Prof. R. K. Shevgaonkar
Department of Electrical Engineering
Indian Institute of Technology, Bombay

Lecture No. # 19
Laser - V Plus Photo Detector

In the last lecture, we saw functioning of two commonly known lasers, the ruby laser and the helium neon laser; also we studied the functioning of the semiconductor laser, which is called the laser diode. So, we saw that if we have the p n junction like an LED, and if we do some polishing, so that there is a positive feedback of the photons, which are generated inside the p n junction. Then the device can be converted in to the laser diode. We also saw that the operation of laser diode is rather more complex.

The characteristics of laser diode has a break that means, this device is more suited for switching kind of action, and that is the reason the laser diode is normally used for digital modulation; whereas, the LEDs are preferred for the analog modulation. We also saw that we require a better temperature control for operation of the laser diode. So that the threshold current can be adjusted, and then we also saw the different time scales involved like the spontaneous lifetime of the carriers, stimulated lifetime of the carriers and the photon lifetime, which essentially has effect on the rate of modulation, which the device can undergo.

In this lecture, let us now try to see some other characteristics of the laser diode, and one of the important characteristics is a noise performance of laser diode; that means when we get the light output from the lasers, the optical power does not remain absolutely steady. There are always some fluctuations in the output power, and these fluctuations get reflected in the form of noise, when we try to detect the signal on the other side. So here, we try to see, what are the different mechanisms, which contribute to the noise into the optical system? So, there are various phenomena, which essentially contribute to the noise. The first one is what is called the reflection noise.

(Refer Slide Time: 03:03)

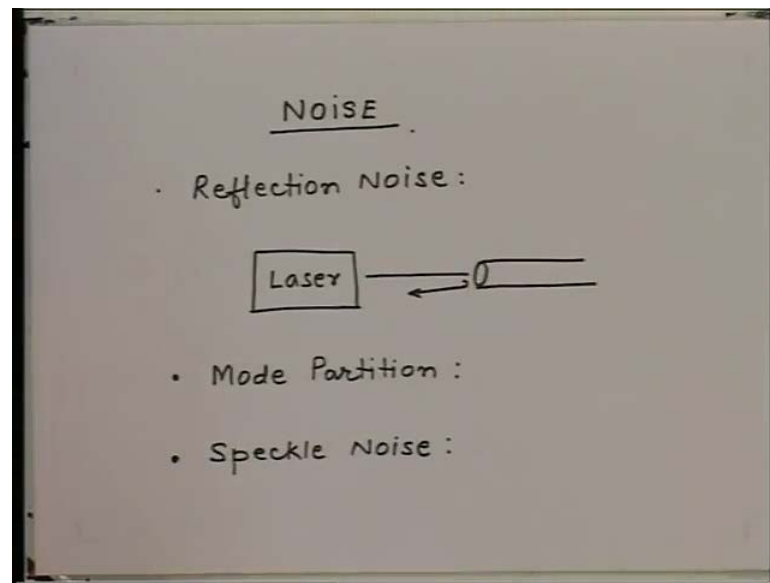

(No audio from 03:01 to 03:16)

So, as the name suggests, this is something to do with the reflection of the signal. So, we can see laser emits the light; the light comes in the form of some kind of a beam. When this light is coupled to the optical fiber, then due to (()) reflection a part of the light is reflected from the tip of the optical fiber. So, you see that whatever light is going from the laser to the optical fiber, the part of this light is reflected back. Now, if the tip of the optical fiber is perfectly aligned with beam, then the reflection from the tip of the optical fiber straight goes back inside the resonant cavity of the laser. So, we now having some kind of a feedback signal, which is coming from the tip of the optical fiber and the phase of this signal depends upon the distance of the tip of the optical fiber from the laser.

So, that means we are having a feedback for which the phase depends upon the separation. And note here since we are talking about a wavelength here which is of the order of a micron, a separation over a distance of of fraction of a micron changes the phase of this signal substantially. So, now because of thermal variation not because of vibrations, if the tip of the optical fiber even varies in position by fraction of a micron, the phase of the reflected signal changes substantially and this signal when it goes inside the resonant cavity, this essentially affects the amplification process. You got now this phase which is reaching here may give you a positive feedback or may try to cancel the signal, which is generated inside. As a result, the gain of this system will depend upon the phase of this signal, which is returned from the tip of the optical fiber.

So, because of the temperature variations or fluctuations on the tip of the optical fiber over the scale of about fraction of micron, the output power of the laser also will fluctuate by small amount; that noise is what is called the reflection noise. The second noise is what is called the mode partition noise. Now, we have seen that in a typical laser, there are many frequencies which get amplified. So, you are having a amplification spectrum and within that, those frequencies will satisfy the phase condition on from the reflecting mirrors, these are the frequencies essentially get amplified inside the laser cavity. So, we do not get a single frequency generation from a laser. We get essentially a set of frequencies generated by a practical laser.

(Refer Slide Time: 06:50)

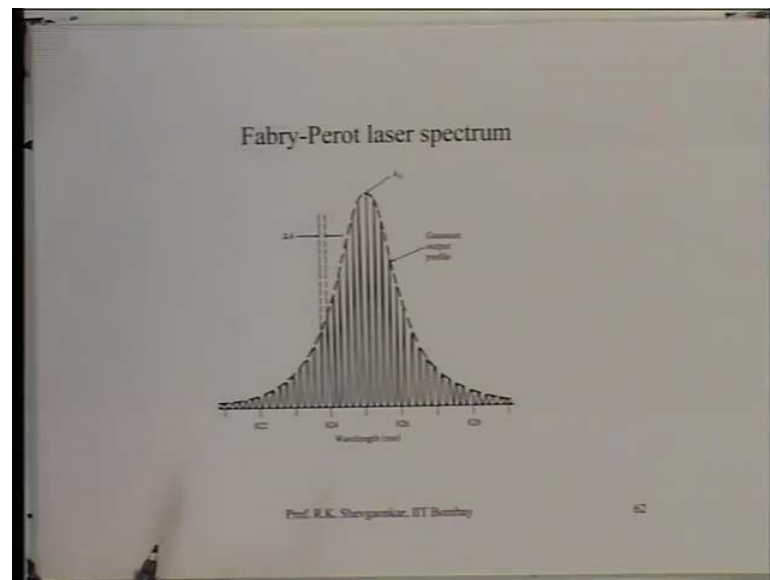

And we had seen earlier, there a typical spectrum of semiconductor laser would look something like this. So, you are having a gain spectrum which is here and these are the frequencies, which essentially are emitted by the laser; because these are the frequencies which do satisfy the phase condition inside the resonant cavity. So, if we expand this spectrum little bit, the separation between these lines typically if the order of about 10th of a nanometer, this width will be typically of the order of about 2 to 3 nanometer. So, you have about twenty thirty lines which are present inside the spectrum.

But what will notice says is **the** this spectrum which you are seen here is an average spectrum. Every line does not have at every instant of time this amplitude. So, if we consider all set of frequencies which are generated by the laser and if we take the average value of the power in each frequency, then we will generate this function which

will be the gain function. But every instant of time if you see inside the laser, every line does not have this profile.

(Refer Slide Time: 08:11)

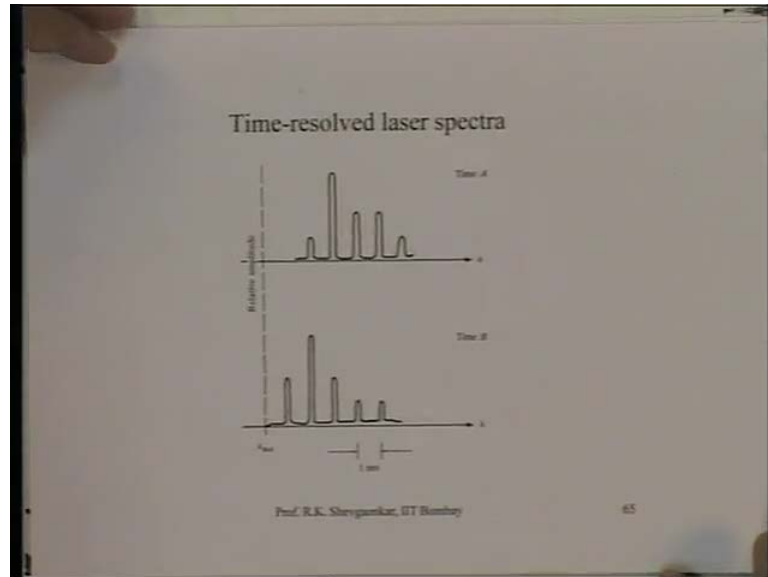

So, we may get a spectrum at some instance of time which might look like this; that means this frequency has more power compared to this frequency. At some other instant of time, the spectrum may change to this. So, what do you find here is that though the average spectrum (Refer Slide Time: 06:50) of the laser looks something like that, the power varies in each of these frequencies as a function of time. So, the total power remains constant inside this. But the distribution of power among different frequencies keeps varying as a function of time, which again contributes to the variation; because various frequencies travel differently inside optical fiber.

So, they essentially contribute to the noise. This noise is what is called the mode partition noise that (Refer Slide Time: 03:03) the power is distributed among different modes of the optical cavity and the power keep fluctuating as a function of time. The third noise is what is called the speckle noise. Now, since large numbers of frequencies are generated inside a laser and when the laser is coupled to the optical fiber, all this frequency essentially get guided inside the optical fiber and then since they travel with different velocity, because of dispersion inside the optical fiber.

(Refer Slide Time: 10:03)

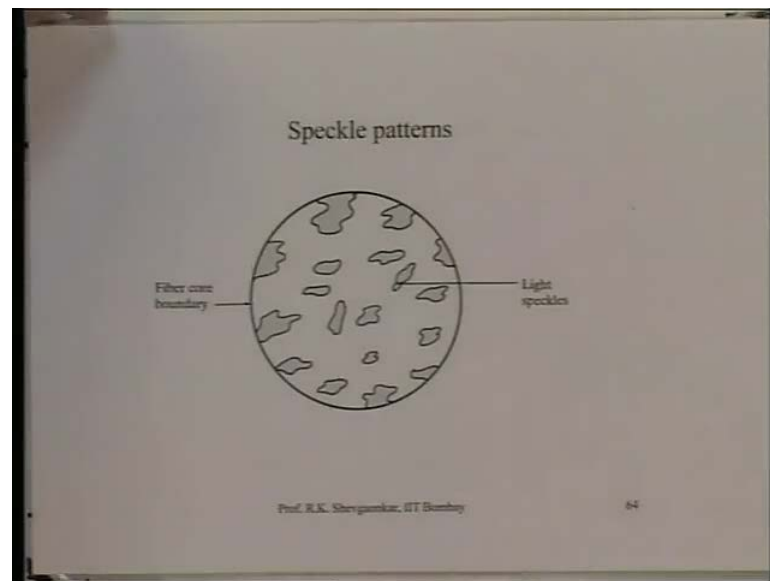

When we reach to the other side of the optical fiber, we essentially see the interference of the fields in different frequencies. So, typically we see the interference phenomena also; this is the cross section of the optical fiber. Somewhere you have the white spots, where you have constructive interference; somewhere we have dark spots, which are due to destructive interference on different fields. So, typically we generate a pattern in the cross sectional plane of the optical fiber with the white and dark spots. This pattern is what is called the speckle pattern. So, wherever we are having a coherent light, speckle phenomena is an integral part of it; because wherever we have the coherent radiation, we have these interference phenomena.

And when we have interference phenomena, somewhere we have destructive interference; somewhere we have constructive interference and because of that we see this bright and dark spots. Note however that the total power which is over this cross section remains constant, the speckle pattern is nothing but a redistribution of the power in the cross sectional plane of the optical fiber. But what happens is that when the light is received on the detector from the optical fiber, the detector does not have absolutely uniform response to all the points in the cross section.

So, these regions where we have dark spots, less power is received by the detector; whereas, in these regions where you have bright region, you get more power. Normally, it should not matter because since the whole power is remaining constant. As long as the total power is collected, the power should not fluctuate as the function of time. However what happens is that because of the temperature variations, different frequencies undergo

different phase changes and as a result, these constructive and destructive interference phenomena keep changing slowly as a function of time. So, the pattern essentially keeps slowly varying as a function of time.

So, a location where you have a dark spot, after sometime this may become bright and this may become dark and so on. So, if the detector response was absolutely uniform, again it would not matter; you would get the total light output. But since the detector response is not absolutely uniform, this variation of light intensity in the cross sectional plane gets slowly varying time component; because the optical power falling on the detector, now varies at different locations in this cross sectional plane. And therefore, the current which flows in to the photo detector slowly varies as a function of time; this is what is called the speckle noise.

So, in practice we have the noises associated with lasers. The reflection noise, the mode partition noise and the speckle noise and also we have seen that because of relaxation oscillations, we may get some variation in the pulse shape that will also contribute to the noise. So, these effects when we **we** will discuss or we will make use of, when we investigate the system part of the optical communication link. Having understood this now, let us now have a comparison between the two optical sources which are available for optical transmission.

(Refer Slide Time: 14:05)

Fiber Optic Transmitter	
<ul style="list-style-type: none">• LED<ul style="list-style-type: none">– Low cost– Low power– Poor power launching– Spectral width 30nm– Short distance– Intensity modulation	<ul style="list-style-type: none">• LASER<ul style="list-style-type: none">– More expensive– High power– Efficient launching– Spectral width 1-2 nm– Good for long haul communication– Coherent communication– ASK, FSK, PSK modulation– Non-linear applications

Prof. R.K. Shrivastava, IIT Bombay 66

So, if we consider a typical optical transmitter, there are now two possibilities; either we can use the LED or we can use the laser diode. So, here the brief comparison of this two

sources. LED is relatively low cost; but it also gives very low power; because as we saw earlier, its efficiency very **very** small. So, the kind of currents which we can manage the power emitted by the LED is rather small. It has a poor power launching efficiency; because as we saw LED is not a directional device. So, especially for the single mode optical fibers, the power launched is relatively low. Also LED has very large spectral width, it could range from about 30 nanometer to 70 to 100 nanometer and consequently it has very large dispersion.

And therefore, the LED transmitters can be used for the short distance communication and since the light is incoherent emitted by the LED, only modulation which is possible in this case is the intensity modulation or the amplitude modulation; whereas, if we go to the laser diode, then the scenario is completely changed. Firstly, the laser diode is relatively more expensive; but it can give you high power, which is useful for long distance communication; also the laser diode gives radiation, which is in the form of a beam. So, we can have a much better launching efficiency inside the single mode optical fiber and also the spectral width of laser diode is of the order of about 1 to 2 nanometers, which is about factor of 50 lower compared to the LED.

So, the dispersion for the laser diode sources also is reduced in the same proportion. So, this transmitter is the one which should be used for long distance communication. So, this device is very good for the long haul communication; whereas, the LED is a device which should be essentially used for the short distance communication. Also the laser diode provides the opportunity to make an optical link, which is based on the coherent communication principle and we can use the modulations not necessarily intensity modulation or the amplitude modulation. But we can use amplitude shift keying, phase shift keying, frequency shift keying; all these are possible because now the spectral width of the source has become very small.

And also since the power is large, there are some interesting phenomena which are what are called the non-linear effects inside the optical fiber. They get induced and they can be used for variety of applications inside the optical communication. So, laser diode essentially opens up lot more applications compared to LED. But as we mentioned, LED being linear device whenever we talk about the analog modulation, LED is still a better choice; whereas for long distance digital communication, the laser diode will be the better device. As the time is progressed, one more thing which happen in the laser technology and that is though the spectral width of the (Refer Slide Time: 06:50) typical

laser diode is of the order of about 1 to 2 nanometers, still this spectral width is large; because now we are talking about the communication distances, which are of the order of about 1000s of kilometers.

So, any device which can have a spectral width smaller is always preferred. So, from LED when we went to laser diode, we decrease the spectral width from about 30 nanometer or 50 nanometer to about 1 to 2 nanometer; but even 1 to 2 nanometer spectral width is large. So, what is now done is that the spectrum of the laser diode is further clean means all these frequencies which are present here; if we create a mechanism, by which only one or two frequencies of the spectrum are the one which are finally emitted by the laser diode. Then we will have much purer spectrum or much narrower spectral width and then that device would be far better for the long distance communication.

So, in this case as we have seen that the feedback is taking place by the mirrors, which are on each side of the resonant cavity. So, essentially we are having a **lumped** feedback. The photon travels up to the end of the cavity and from the end of the cavity, it get reflected back. While discussing the optical fiber, we have seen the phenomena what is called the mode coupling. We have seen that if you are having perturbations inside the optical fiber and if the period of the perturbation is equal to the beat length of the two modes, then there is a strong coupling between the two modes. Precisely, these phenomena now we can use for selectively coupling the frequencies, which are travelling in the opposite directions.

So, instead of having a region, where the light generation takes place or amplification takes place and the mirrors over which the feedback take place, suppose we create a structure where the feedback is all through and the wave, which are travelling in the opposite direction for certain frequencies, they have a strong interaction and this interaction will decide upon the perturbation, which you are having in to that region. Then one can satisfy this condition of strong coupling only for very selective frequencies inside the spectrum. So, since we are now doing the coupling of the mode, which are travelling in the opposite directions and not the feedback at the ends. Essentially, now the feedback mechanism is distributed inside the cavity and therefore, we call this laser as a distributed feedback laser.

(Refer Slide Time: 21:35)

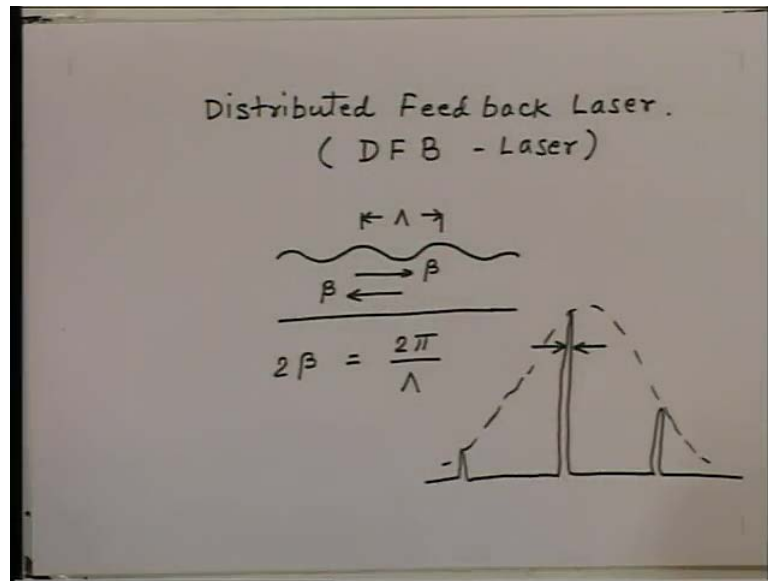

So, the most recent lasers which are used for optical communication are what are called the distributed feedback lasers or in short, it is called the DFB laser. So that I mentioned the idea here is follows; initially, we had a region where the amplification was taking place. So, let us say now that active region does not have a flat surface like this; well it is having a variation which is something like that. So, we have two waves which are propagating in this direction and both the waves are having let us say the phase constant beta; then this perturbation period lambda capital lambda. We will have a strong coupling between these two fields.

If the difference between the two propagation constant and see they are travelling in the opposite direction, that will be equal to 2 beta that will be equal to 2 pi divided by lambda. So, essentially what we get from here that if 2 beta is equal to 2 pi divided by capital lambda, then these two modes will get very strongly coupled or in other words, they will be a feedback from these two modes from one to another. So, now from here essentially we can find out the wavelength, for which there will be a strong coupling. So, out of these frequencies (Refer Slide Time: 06:50) which are supported by the intrinsic gain function of your laser diode.

If we create this perturbation inside the p n junction, there only very few frequencies essentially would satisfy this **condition the** feedback condition of the distributed nature. And therefore, the whole spectrum now will not show amplification; but very few lines in this will show the amplification. So, by proper choice if I make sure that only this line shows amplification or then next one line will be this will show amplification and this

will show amplification; essentially I have created only a single line generated by the laser. So, instead of a spectrum which was originally generating lot of lines, now the spectrum which will be created by the laser may look something like this.

Now, since these amplitudes are much smaller compared to this amplitude, the laser essentially has emitted a frequency which is this frequency. So, now the spectral width has effectively become this, which is very, very small and this spectral width could be in frequency terms, it could be of the order of few hundred megahertz or gigahertz; that means, now the laser spectrum has become very, very clean or now we can say that this laser can be treated more like a monochromatic light emitter. Note here that when we talk about dispersion, we found that the whole transmission process can be visualized as the multichannel transmission; because there are large number of frequencies, which are present inside the source.

Each frequency travel with different velocity and because of there is a pulse broadening. Also we had seen that since the spectrum is much larger for the intrinsic source compared to the modulation frequency, the spectrum is completely washed out. And we do not have information about modulating signal inside the spectrum. The scenario now can be completely changed; because if this width becomes few hundred megahertz and if we use the data rate which is typically of the order of about few gigahertz, then the side band separation now will be much more than this width or in other words, now the spectrum can very clearly see the side bands of the modulated signal.

And if that happens, then one can use all the techniques which are used for the sophisticated communication like synchronous detection systems, coherent detection systems. They all can be employed now; because the spectrum of the modulated signal is clearly visible. So, infact that DFB laser has changed the scenario of high speed optical communication completely; because now we do not have to treat. This is just like a source of power generation. We can actually employ all the sophisticated communication techniques to improve the performance of the optical communication.

So, DFB laser is one of the very important components, which is emerged in last decade; which has made the long distance communication possible with all sophisticated techniques employed in the transmission of the information. So, this essentially completes the discussion on the optical sources. So, let us take a recap what we have discussed up till now in the sources. Right from the beginning, we identified the

characteristics which we are looking for an optical source. We saw that for optical communication, the good source should have as low spectral width as possible from dispersion point of view and it should be efficient. So, that the light can be generated and guided effectively inside the optical fiber.

We also saw that among various possibilities, the semiconductor based devices are preferred; because they have a better integration capability with the electronic circuitry. With that, essentially we went to the semiconductor base device what is called the p n junction. And original form the p n junction is what is called the light emitting diode to identify the materials, which are what are called the direct band gap materials. If you create a p n junction out of it and if you have a forward bias, the electron holes will recombine and the light will get generated. And intrinsically, the light is incoherent; because when the photon is bound, it does not have any history.

So, you see the photons will start moving in different directions. Also we have a very wide band of frequencies which are generated by LEDs. And then by using some innovative ideas, essentially we converted this LED in to a device what is called laser diode, which can give a much better quality light from optical communication view point; that means, it could give the spectrum which was narrower compared to LED by factor of 20 to 50. And also it could generate the power much more efficiently and could launch the power inside especially the single mode optical fiber much more efficiently and then we saw the comparison between these two devices.

And then we saw the special device, which is improved version of the simple laser diode what is called the distributed feedback laser diode, which has a spectral width much **much** lesser compared to normal laser diode. And with this device, then one can employ all sophisticated modulation techniques, which are spectrum based. And one does not have to depend only upon the amplitude modulation as we could do with LED. So, we can do the modulation, which is amplitude shift keying or phase shift keying or frequency shift keying and the communication system performance can be increased by orders of magnitude. With this understanding, now let us go to the other end of the optical fiber, where the light detection process takes place.

Say, as we have seen that the light generated by this optical sources or transmitters, they are guided inside the optical fiber. Light travels inside the optical fiber over hundreds of kilometers and finally when it reaches to the other end of the fiber, this again has to be

converted back in to the electronic form. So, now we are looking for a process, which is the opposite process of the light generation; that is we have light and we want to get now the electric current or the voltage, which is related to the light which is coming from an optical fiber. So, before we get in to this, let us first sort of characterize or let us spell out what are the characteristics we are looking for this device.

(Refer Slide Time: 32:50)

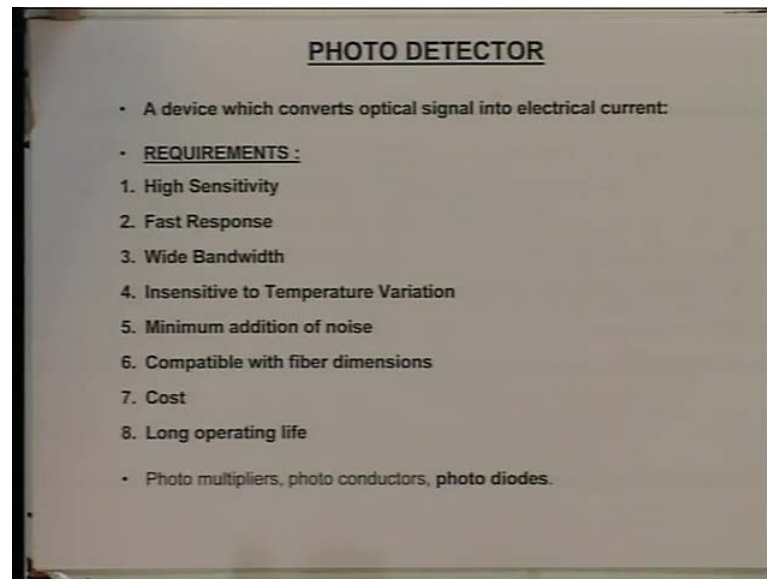

So, firstly this device is we call as the photo detector; that is the device which detects the light; that mean it converts the optical signal in to the electrical current. So, the photo detector is a device, which converts optical signal in to the electrical current. And as we can see that we should have a essentially signal wise, this current should be a replica of the optical signal that means whatever is the time variation we have in the optical signal, it should get faithfully reproduced inside the corresponding electrical signal, so that the information is required on the other side faithfully. So, for a general photo detector, we have some requirements; very first requirement for photo detector is it should have a very high sensitivity.

Now, note the light which is typically generated inside the optical transmitter is of the order of about milli watt, may be 10 milli watt. If you consider a distance of 100 kilometer and fiber has let us say a loss of about 0.3 db per kilometer, typically signal will undergo a loss of about 30 db. So, if I consider one milli watt of power transmitted by the transmitter and there is a loss, which is 30 db; that means factor of thousand. The power which is received on the other side of the optical fiber is one microwatt. So, we are essentially talking about very small powers on the detector sight of the optical fiber.

And that is the reason we should be able to detect that the small power and this device should have a very high sensitivity; that mean you should be able to respond to the very low optical intensities.

Secondly, the device whatever this device we are talking about, it should be able to respond to the variation of the optical signal at a fast rate. So, that we have a faithful reproduction of the signal on the electrical sight. So, the device should have a fast response. The third thing which is not very obvious is that this device should have a wide bandwidth. Now, note when we are talking about the optical transmitters or optical sources, we wanted the bandwidth of the device to be as narrow as possible from the dispersion point of view. Here, however we are saying the opposite that this device should have a large bandwidth. The reason for this is that once the detector is connected to the optical fiber, it essentially is going to respond to the light which is emerging from the optical fiber.

So, since other light is not present there, whatever light comes from the optical fiber that is the light, which is detected by the detector; so, transmitter side we had a requirement for narrow spectral width; because the dispersion would be low, if we take narrow spectral width. But for on the receiver side, the requirement is not there. Secondly, suppose we change the wavelength on the transmitter side, since there is no frequency selectivity required greatly on the detector side. It will not be essential to change the detector, if we change the transmitter. So, if you provide a detector which can respond to over a very wide band, then even if we change the transmitter wavelength or transmitter frequency, the same detector can be used.

So, that is the reason we preferred to have the detector with a bandwidth as large as possible. So that, it need not require any change, even if the transmitter frequency has changed; also this device should be insensitive to temperature variation. We will see later that the kind of detection we are talking about here. It gives you the current which are very very small and they could be comparable to the thermal currents and therefore, you may have a variation in this current; because of temperature variations. So, we want to reduce the effect of temperature variation on this device. Also we will see later on that detection process is not a steady or deterministic process; it is more like a statistical process.

So, whenever we have the light detection, you have some noise generated or you have some fluctuation in the current, which is coming out of a photo detector; that contribution should be as small as possible. Also should be compatible with the fiber dimensions and cost and long operating life; these are always requirements for any electronic components. So, firstly if we consider the first few requirements, you may have many choices; you may get take a photo multiplier or you may consider a photo conductor. But if we consider these later choices, it should be compatible with the fiber dimensions. It should be compatible with the electronic circuitry. We again are guided by the semiconductor based devices and then we get a device what is called the photo diode again.

So, it is again a p n junction made of semiconducting material and now, this junction is used exactly for the reverse operation than what was happening in the LED. So, in the LED, we were injecting the current; recombination was taking place; light was generating. Here, what we want to do is we want to absorb the light inside the semiconducting material, which will generate electron hole pairs. If we create a mechanism to collect the electron hole pairs, then we can have current and these current characteristics will be related to the incident light. So, again is interesting that the same p n junction now can be used for the photo detection also. So, here are certain characteristics of the materials, which can be used for photo detection.

(Refer Slide Time: 40:13)

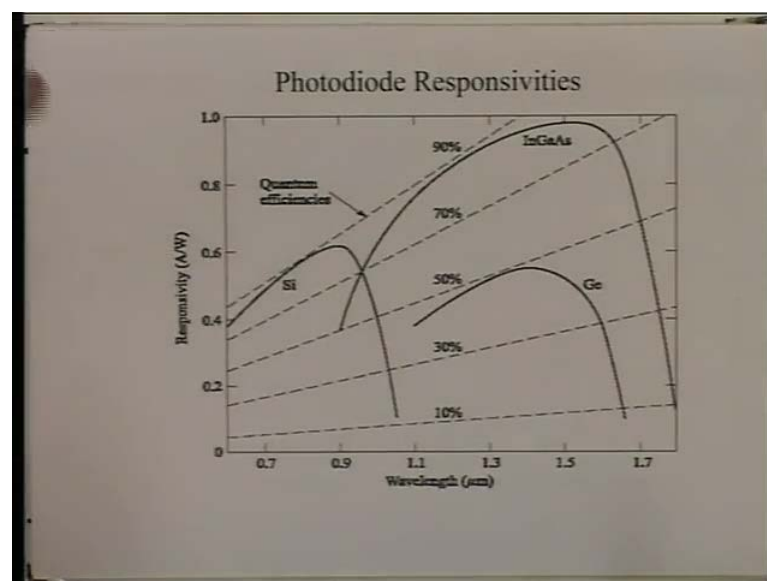

So, what is shown here is the response of the photo detector as a function of wavelength. Say, see here this is frequency response of silicon and these are the longer wavelengths,

which fall in the forbidden gap of silicon material. So, this wavelength cannot excite the silicon. Say, essentially the process which we are talking about here is an absorption process. So, you are having a semiconducting material with a certain band gap. When the light is incident; if the energy of the photon is greater than the band gap, then the electron will get excited; all you have is recombination. So, since these frequencies are longer wavelengths correspond to the forbidden band gap of silicon, the silicon does not respond to these wavelengths.

Say we can see very easily that this material silicon cannot be used for detection of light especially in that frequency range, which is used for optical communication. Note the optical communication is going to take place either in this band here, which is 1.3 micrometer or 1.55 micrometer, which is somewhere here. Also one should note here that for detection process, you do not require material to be direct band gap. Even indirect band gap material is okay; because we are essentially looking for absorption of the photon. So, material like germanium it has a frequency response, which covers this frequency band a 1.3 micrometer or 1.55 micrometer. So, germanium is one of the possibilities for making optical detectors.

The material however which is more useful is this ternary material which is indium, gallium, arsenide. Firstly, its response is much more compared to germanium. Secondly, it has reasonably wide bandwidth characteristics as we desire. So that, in future whenever we try to use large number of wavelengths for transmission, the same detector can detect the light. So, you see this is the material, which can sort of cover the frequencies going from almost 1100 nanometer to about 1700 nanometer. So, either we can use the detector, which are germanium based or we can use the ternary materials which is indium, gallium, arsenide, or some other combinations. Having taken the material, then one can say that let us now ask how the light absorption is going to take place inside this.

(Refer Slide Time: 43:39)

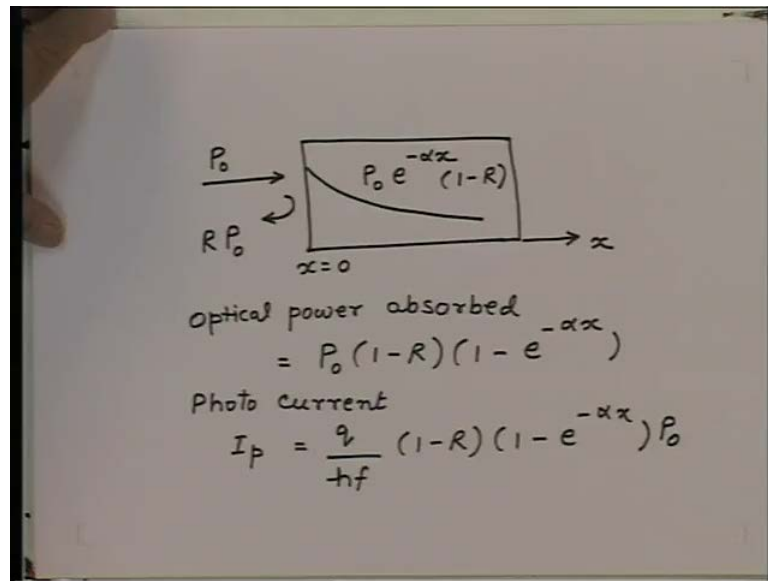

So, let us say we have now a material on which the optical light is incident. So, there is a optical power, which is incident on this; let us say the power is P_0 . Now, as the light beam goes inside because of absorption, the intensity of light will reduce. So, you have an exponential decay of the beam as we go inside the material. So, this variation will be $P_0 e^{-\alpha x}$, where this is the x direction and this point is x equal to zero; so let us say this is x equal to 0. Also note here that when the light beam is incident on this, you may have some power which is reflected from this point. So, let us say the reflection coefficient of this is some R . So, you will have the power reflected, which is $R P_0$.

So, in fact the power which is just getting inside this optical fiber or the detector device is not P_0 ; but it is $(1-R) P_0$. So, you have to actually multiply this quantity by $(1-R)$. Now, the power absorbed over a distance x inside this is nothing but what is the power which is incident on this minus what power remains at this location. Say, if you do all that you will see that the total power absorbed will be equal to $P_0 (1-R) (1 - e^{-\alpha x})$; that is the power absorption, which is taken place inside this region. So, now if I divide this power by the energy of the photon, I will get the number of photons per second.

And if I could collect all this photon in the external circuitry or the photon is now going to generate the carriers; so let us say if the carrier charge is q , then for each photon absorption we are worrying about any efficiency factor here. Every photon essentially is going to generate a carrier. So, if I divide this quantity by the energy of the photon, then I

will get the number of photons and for each photon, I generate one carrier. So, I get number of carriers. If I multiply that by the charge of the carrier, I essentially get the current; because these are the carriers per second, which are going to flow from this device. So, we get the photo current now. Let us say it is denoted by I_p ; that is nothing but this quantity multiplied by the charge of the carrier divided by the energy of the photon.

So, we get q which is charge of the carrier divided by energy of the photon, which is $h f$ into $1 - R$ to $1 - e^{-\alpha x}$. So, knowing this now we can find out what is the photo current which can be generated and if we consider now this quantity of course just we multiplied by P_0 . So, now if I take this quantity I_p divided by P_0 , it essentially accounts for all the device factors; for example, energy of the photon, the reflectivity of the material, how much is the absorption length over which the radiation is getting absorbed and so on. So, the ratio of I_p to P_0 is something like a characteristic parameter which you have for a device. This essentially is what is called the responsivity of the material.

(Refer Slide Time: 48:50)

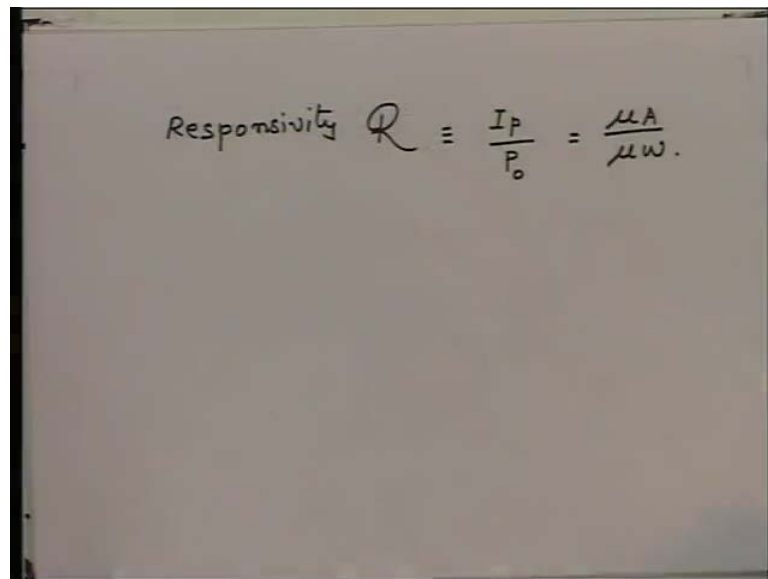

$$\text{Responsivity } R \equiv \frac{I_p}{P_0} = \frac{\mu A}{\mu W}$$

So, we have an important parameter for this what is called the responsivity. Let us say, we denote this by R ; that is equal to I_p divided by P_0 . So, if we assume that (Refer Slide Time: 43:39) every photon had not generated a carrier, then you may have some efficiency factor associated with that; which we can call as the quantum efficiency. Then the ratio of I_p to P_0 will be that quantum efficiency multiplied by q upon $h f$ into $1 - R$ into this quantity. So, a device now is essentially characterized by this, which

takes in to account all the factors and as we can see the unit for this will be some microamperes per microwatt.

Though we can call this unit as a ampere per watt, normally we do not do that; we still call microampere per microwatt. Because in photo detector, the current which we deal with are typically microamperes and the power for optical, which we deal with is again typically of the order of about microwatts especially on the receiver side. So, responsivity is given in terms of microampere or microwatt. So, this is one of the important parameters for a detector and thus the quantity essentially is shown here.

(Refer Slide Time: 40:13) In this plot, we have got here a responsivity which is ampere by per watt, which is microampere per microwatt. Say, you can see that here we are having almost like one microampere per microwatt of power generation for this. So, this parameter now would characterize the performance of a photo detector. So, germanium for example, would have a typical efficiency of about 50 percent compared to what you will get from the indium, gallium, arsenide. So, this device is much more sensitive compared to this device. Once we do this, then now the carriers are generated and now these carriers are to be collected.

(Refer Slide Time: 51:40)

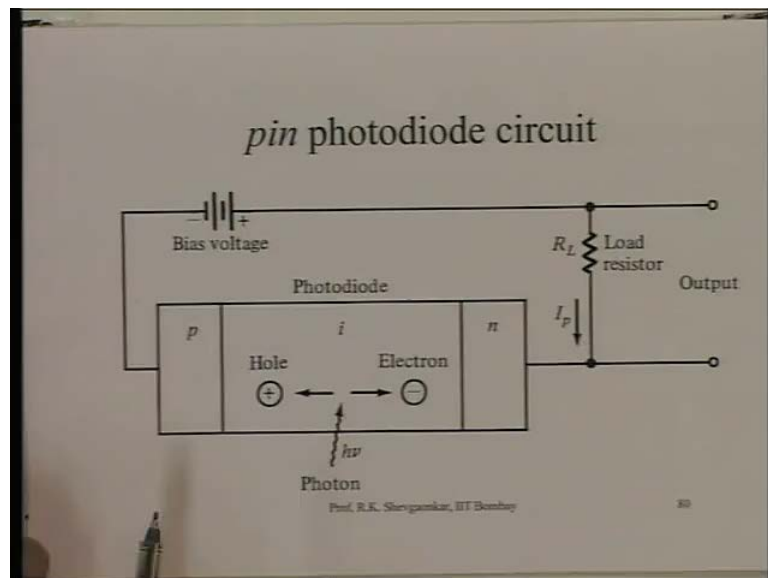

And for that, essentially we create a device which is a junction; which is the p n junction.

(Refer Slide Time: 51:44)

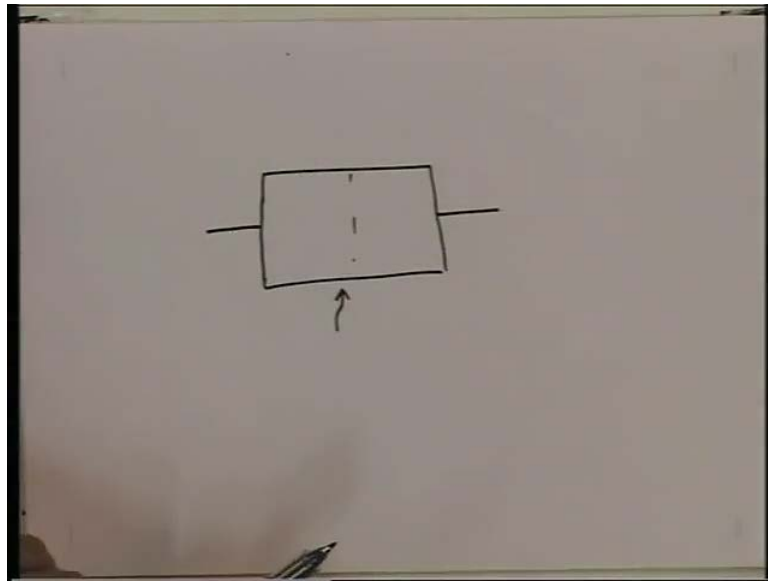

So, if we consider a simple p n junction, and then if the light is absorbed inside the p n junction, so light is absorbed here; so the photons are incident in this; electron hole pairs are generated in this some region here. If we apply a potential difference between these two, then these carriers will be collected on either side. And if you are having circuit connected externally, then these carriers will flow, and we have a current flow. So, that is the basic principle of the photo detector that we should have a material, which has a good absorption of light at the desired wavelengths.

And once the carriers are generated, then these carriers have to be collected effectively and efficiently, so that there is a current flow in external circuitry and if you are having a one to one relationship between the current, which is flowing in the external circuitry and the optical power, which is incident, then essentially the information is efficiently converted from the optical to the electrical converter. So, we will continue with this discussion, and we will have further characteristics of the photo detector. And see how this can be used, and what are the issues involved in making use of this device in to the detection of light for the optical communication.