

Marine Construction & Welding
Prof. Dr. N. R. Mandal
Department of Ocean engineering & Naval Architecture
Indian Institute of Technology, Kharagpur

Module No. # 01
Lecture No. # 33
Electroslag Welding

(Refer Slide Time: 00:25)

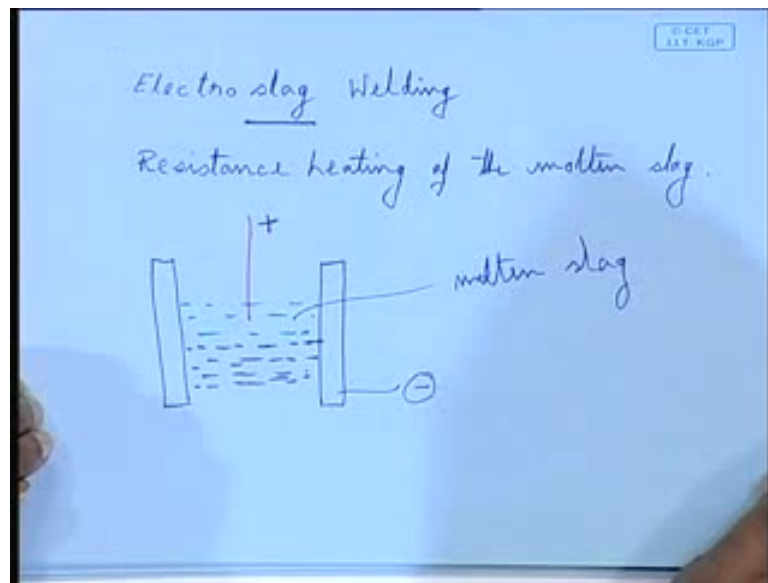

We will look in to one more welding process which is referred to as electro slag welding **electro slag welding**. Here, till now all the welding process we have seen, there the heat was generated through welding arc, through an electric arc. In this process, electro slag welding, as you can see the name slag, what happens there, resistance heating of the molten slag is used, the resistance heating, that means essentially, schematically it could be like this.

Suppose, if I assume a situation in this form, that here I have molten metal, here you have a molten slag, and the electrode is dipped in it, in the molten slag. This is my molten metal here, below, and this is green lines as if the molten slag.

So, the current is passing through the, this is my electrode, say, I have kept it positive, and the job, suppose, this is my job, I have kept it negative. So, the circuit, the current is

flowing through the molten slag; the electrode is dipped in the molten slag; that is how the heating is done. We will come, how the molten slag has come at the first place. What I wanted to say that, here, in the previous welding methods, we got the heat because for doing welding, we are doing thermal welding, so, heat is needed for melting the electrode as well as melting the base metal; it was obtained through electric arc, a plasma column was formed that generated the heat.

(Refer Slide Time: 02:41)

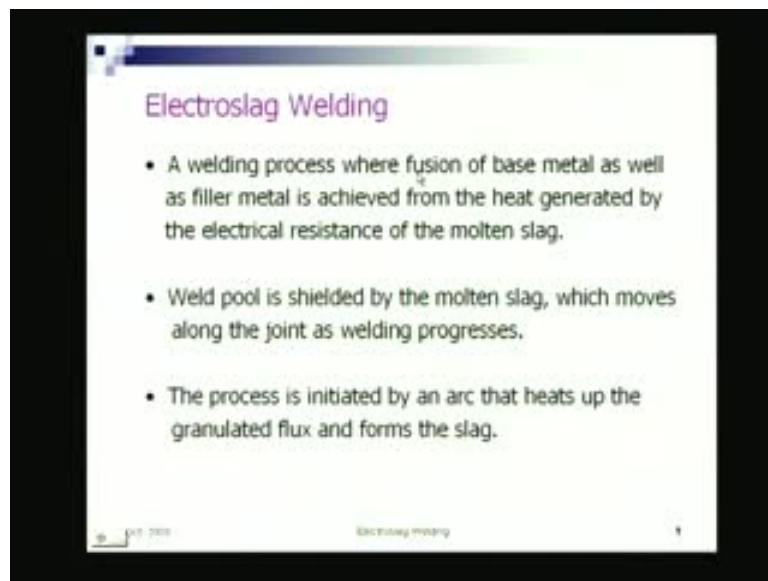

Here, it is the Joule heating or the resistance heating of the molten slag that is how, so, this is the fundamental difference. In electro slag welding, the heat source is from the molten slag, the Joule heating of the molten slag. So, what do you see that, it is a fusion welding process definitely; here the fusion is achieved from the heat generated by the electrical resistance of the molten slag, here and the weld pool, as you can see in this schematic.

(Refer Slide Time: 03:01)

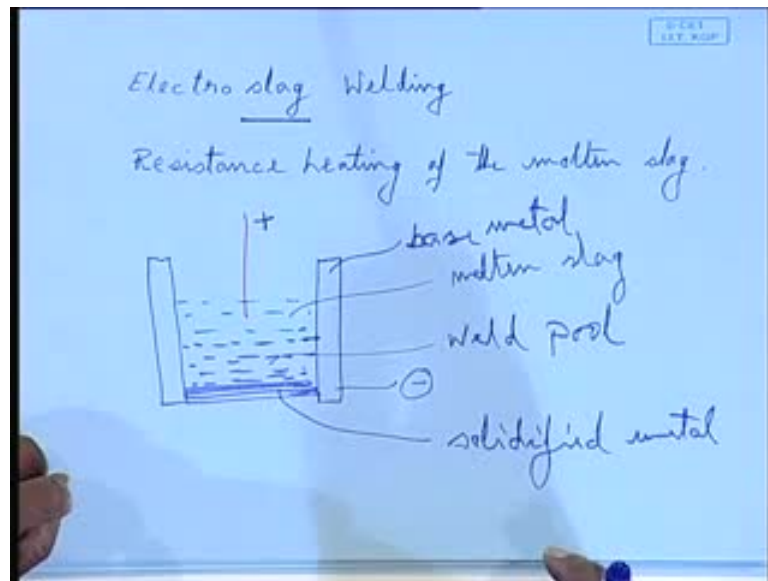

This is my weld pool and below that is the solidified metal, this is my weld pool.

(Refer Slide Time: 04:17)

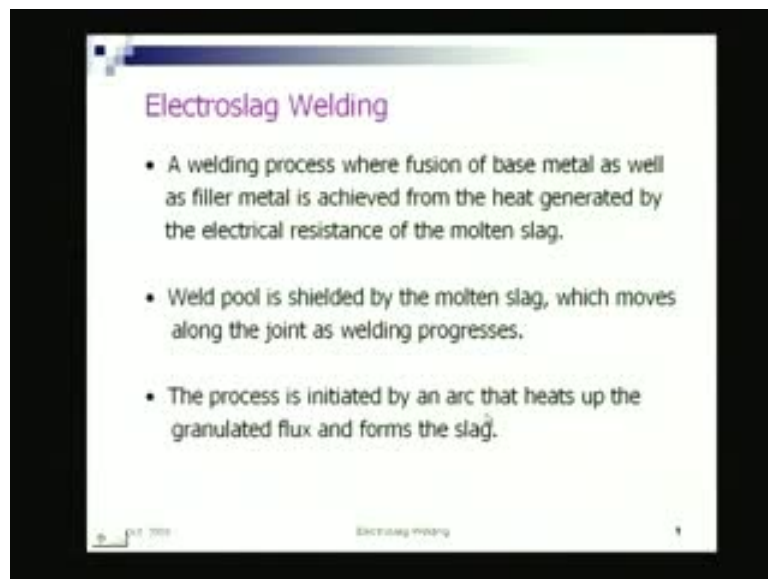

This is the base metal. So, from this possibly you can figure out that this process is a vertical welding process. The weld metal, the weld pool, the molten metal over that the molten slag is floating, so, it ought to be vertical, right, and this whole thing will go keep moving up, so, what is happening, as it is moving up the molten metal gradually is getting solidified, that is the solidified metal below. This is the solidified metal. So, electro slag welding is essentially vertical welding process, where in, the heat is

generated from the molten slag electrode is melted and gets deposited and the whole thing keeps moving up you the welding is done.

(Refer Slide Time: 04:30)

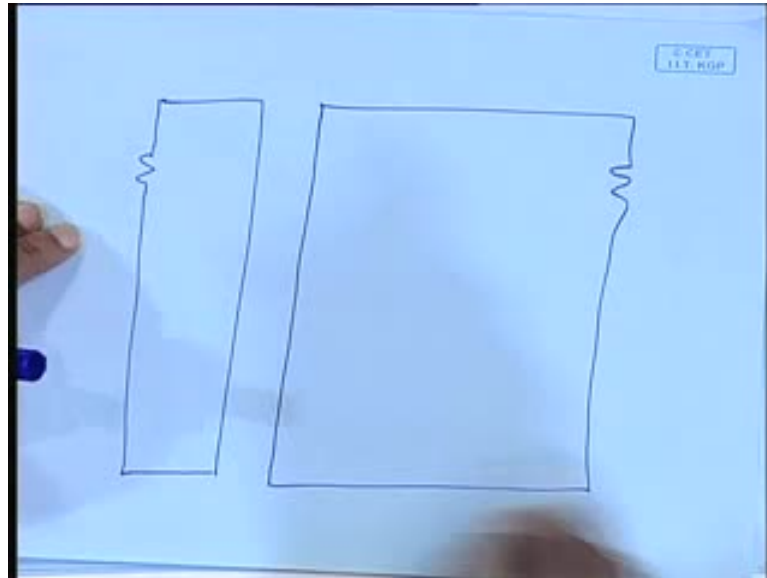

(Refer Slide Time: 04:47)

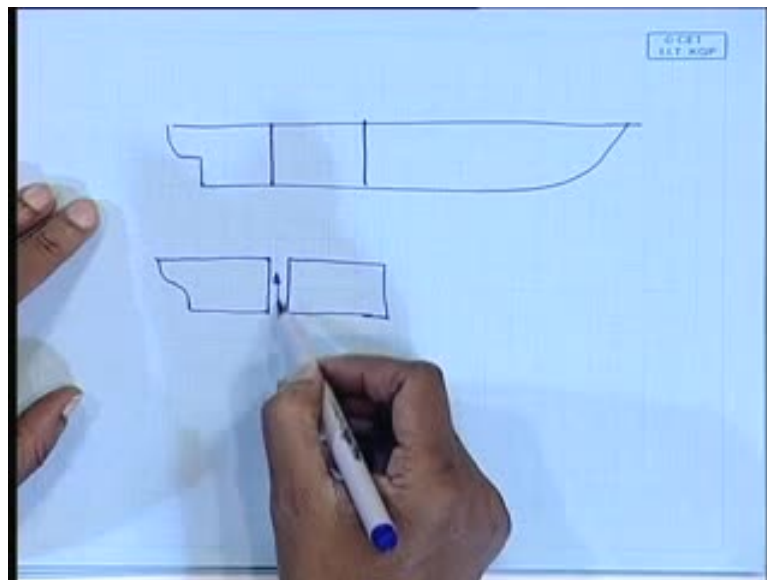

So, the process how it is initiated is initiated by an arc. That means, at the starting point, at the starting point it is initiated by an arc, that means, if you see, suppose, this is a vertical plate, these are my two particle plates; assume the case of, this is the, say a ship which has been fabricated in this fashion block by block.

(Refer Slide Time: 05:26)

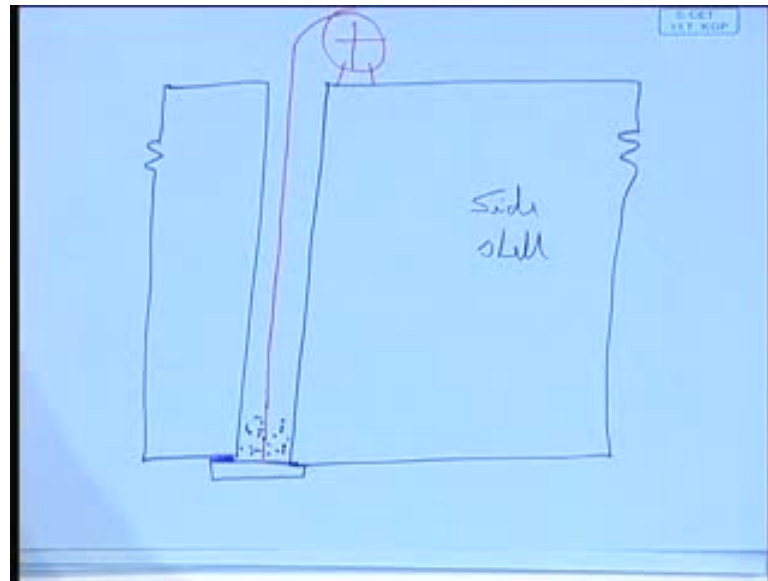

Say two blocks, they have been separate, I mean, the utter block, the uttermost block, the engine room block, they have been fabricated separately; now, we are putting them together. So, this welding, this vertical welding, this vertical welding is something like this, they are the two side shells, in case of a ship. These are the two shells, alright. So, here, if we think a situation like this, this is some my backing plate; you have the so called the granulated flux is poured here, at the beginning, the starting point. You have the electrode; I have a mechanism through which I can put the electrode down from a spool at the deck.

(Refer Slide Time: 06:52)

Electroslag Welding

- A welding process where fusion of base metal as well as filler metal is achieved from the heat generated by the electrical resistance of the molten slag.
- Weld pool is shielded by the molten slag, which moves along the joint as welding progresses.
- The process is initiated by an arc that heats up the granulated flux and forms the slag.

ppt 2016 Electroslag welding 1

(Refer Slide Time: 06:56)

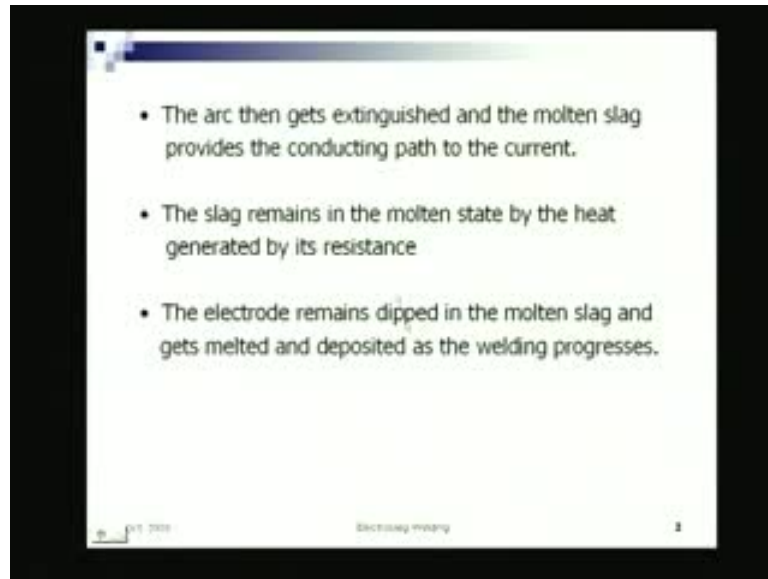

(Refer Slide Time: 07:11)

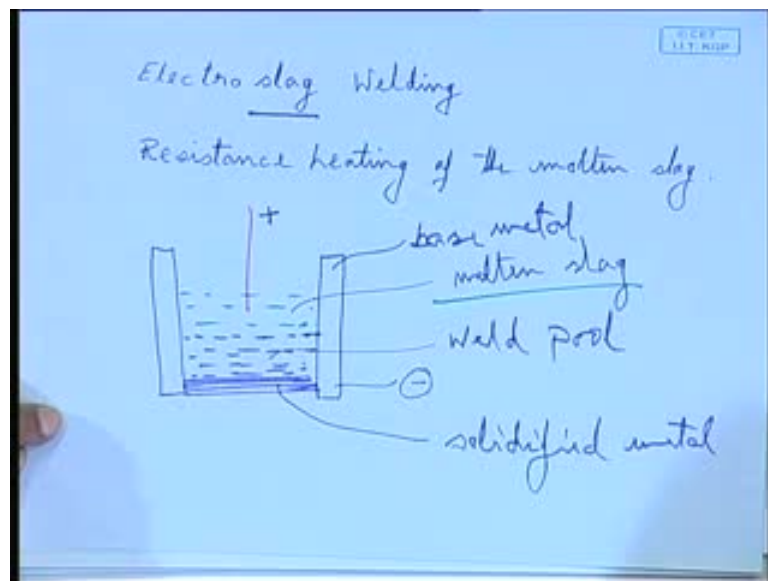

Imagine such a situation - the electrode is coming down, it comes and strikes an arc at the bottom; initially it strikes a normal electric arc. In that arc, this flux melts; melts means essentially burns forms slag and that slag remains in molten state, because in other welding processes, we have seen the slag was in molten state, but as the heat source is moving out, slag is getting solidified, but here, the heat source is not moving out, heat source is the molten slag itself. So, when it strikes the arc, then it burns the flux and forms the so called slag, and at that point, the arc is extinguished; electrode remains

dipped in that molten slag bath, in the molten slag bath, electrode remains dipped in this fashion in the molten slag bath.

(Refer Slide Time: 07:20)

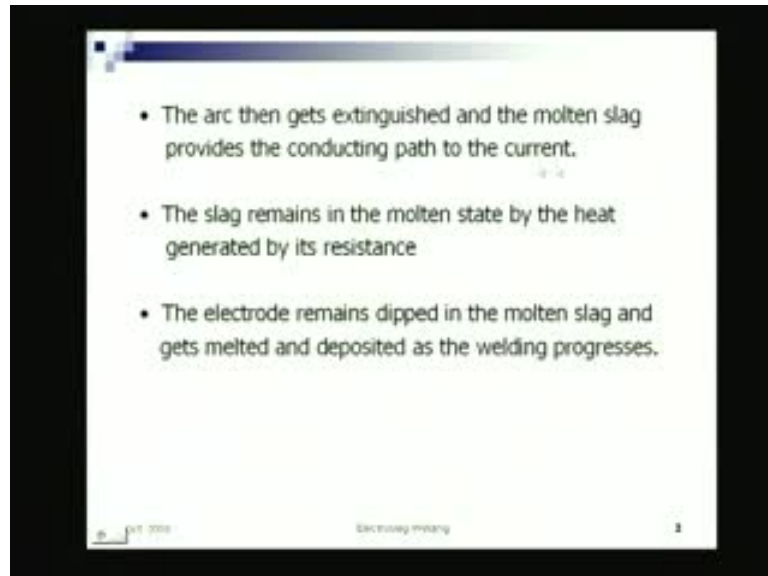

(Refer Slide Time: 07:36)

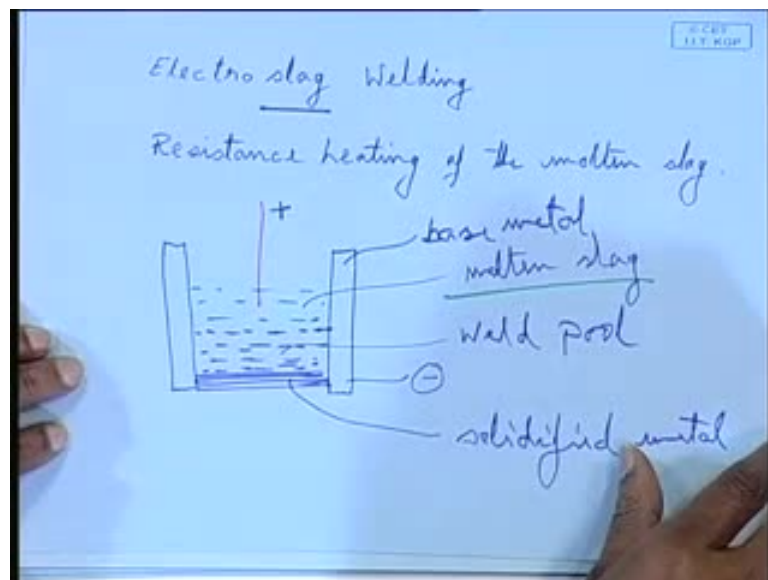

(Refer Slide Time: 07:50)

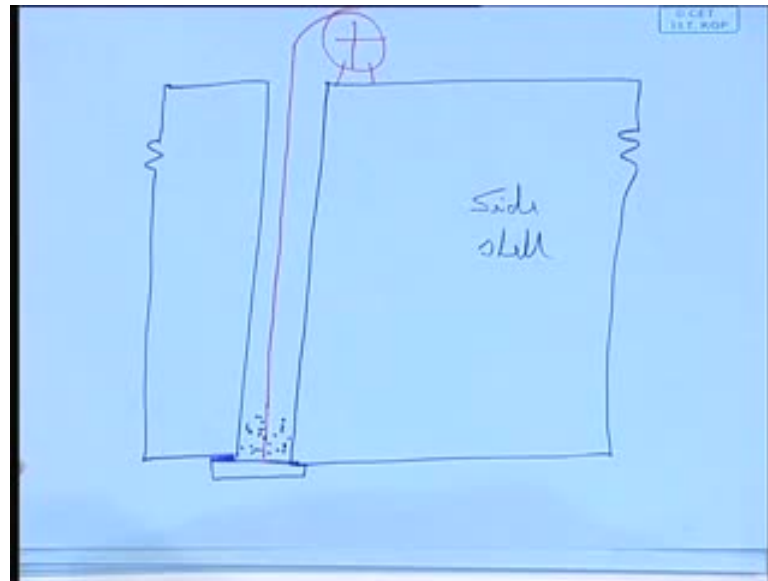

(Refer Slide Time: 08:02)

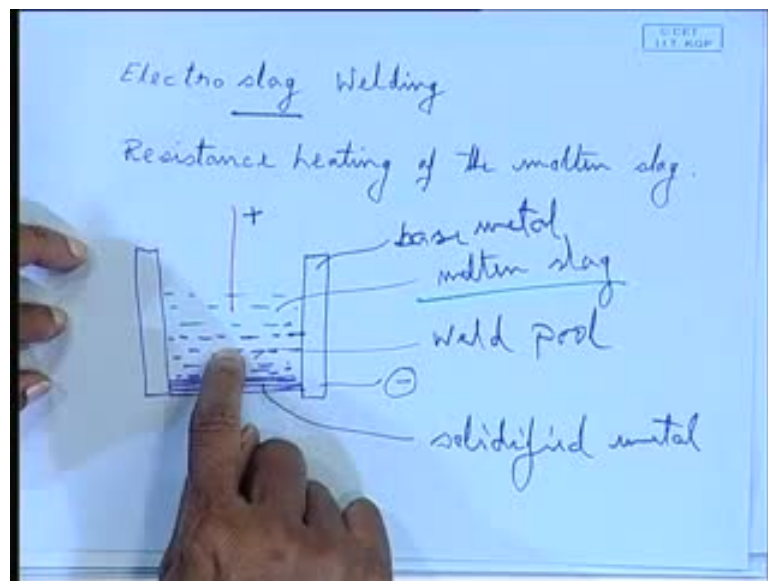

So, thereby, that gives the necessary heat. So, the molten slag provides a conducting path to the current. The slag remains in the molten state and the heat is generated by its resistance. The electrical resistance of the slag which generates the heat, that is very simple because, if we know the electrical resistance, the amount of current going in $I^2 r$ is the heat generated. So, that heat melts the electrode; it melts the electrode as well as melts the base metal. Now, the question is how to confine this molten slag as well as this molten metal, the molten slag, you will have to confine, is not it; otherwise, it is peel off.

(Refer Slide Time: 08:06)

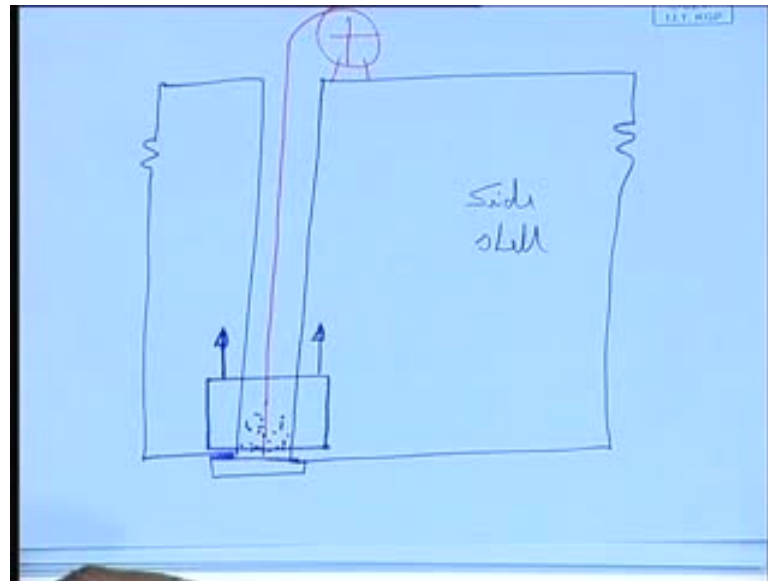

(Refer Slide Time: 08:32)

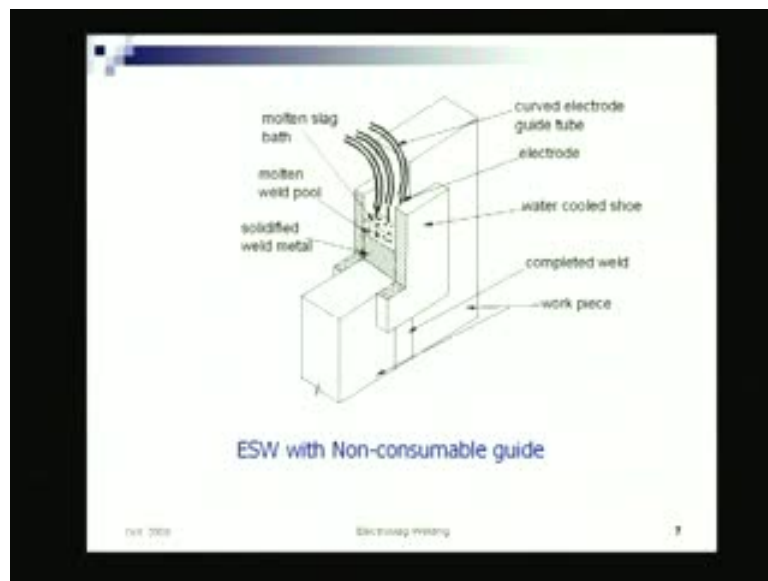

So, what is done is you have a kind of a mechanism, think of a shoe some kind of plates which is sticking to the plate surface, and they have a mechanism to pull it up. So, there are two shoes, I mean schematically something like this. So, there are the two plates, there are the two plate's parts of the side shells. This is one shoe on one side; another shoe on the other side. This hatched one, this is another plate, this is another plate, one on the front side; one on the back side; sticking to the surface and they are going up. So, they are holding the molten metal as well as the molten flux, molten slag. That is how the welding is done. It is just a matter of making this arrangement work, that means you put

the this two pieces of plates which are referred to as shoe which will slide up and no metal will leak out, that is how is the process.

(Refer Slide Time: 09:34)

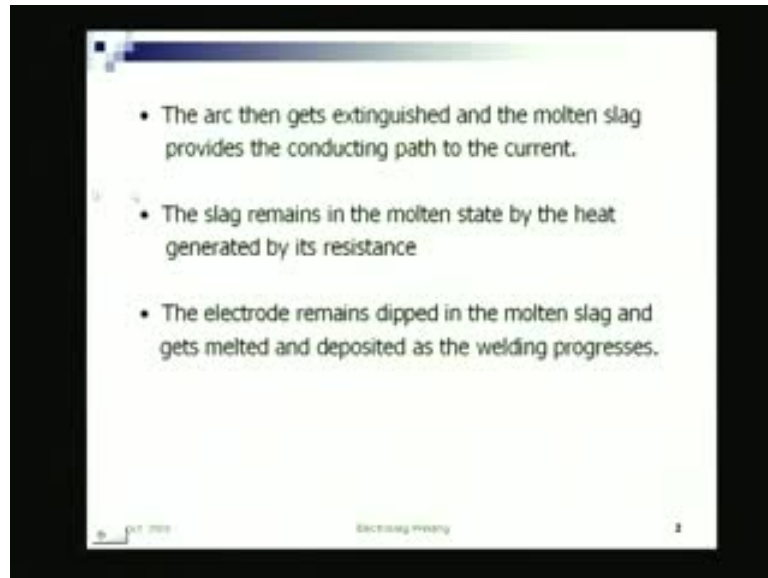

So, what do we see is, that, here, in this process, the electrode, in all the other processes, the electrode never touched the plate surface, or the molten pool like that, there was a arc. Here also it is not touching the molten metal, the molten pool; it is touching the molten slag pool. Through the molten slag, the current is flowing and that heat is giving, that heat is being used to melt the metal. So, the electrode remains dipped in the molten slag and gets melted and deposited as the welding progresses.

(Refer Slide Time: 10:14)

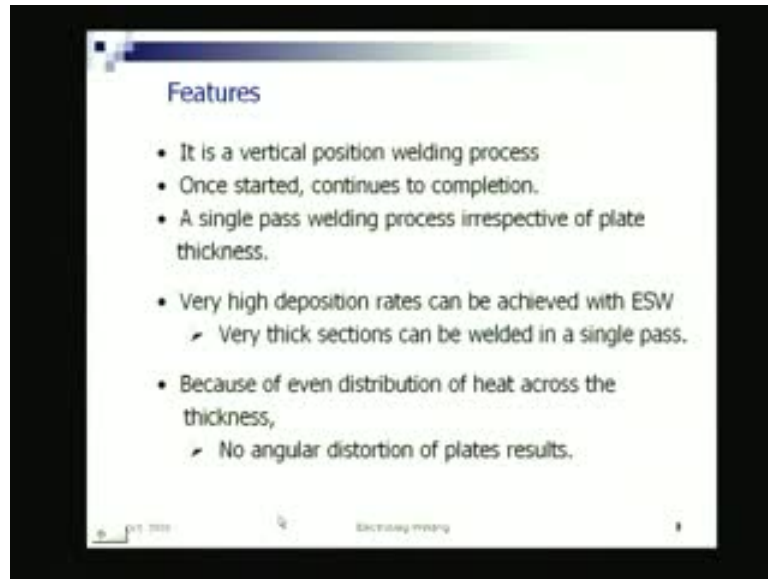

(Refer Slide Time: 10:38)

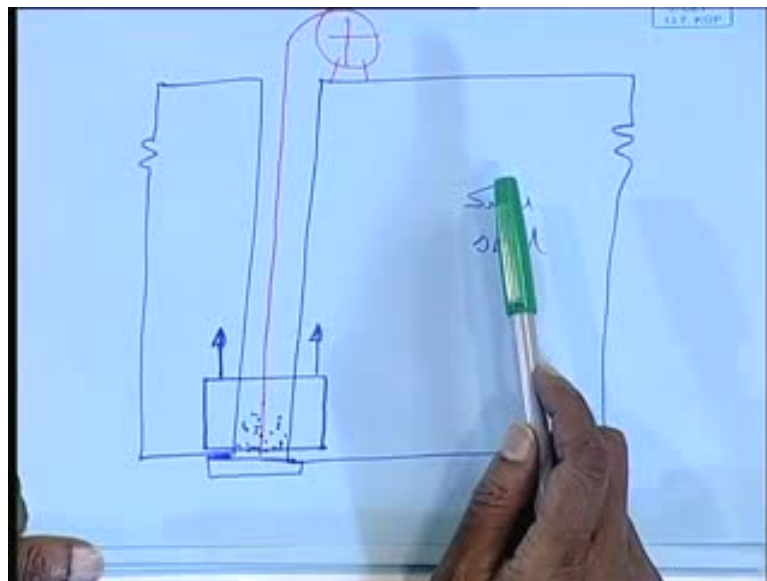

So, what are the features? As you can see the features are it is a vertical position welding, there is the first and foremost as we have seen is a vertical like submerged arc welding is only down hand welding, whereas, gas metal arc or shielded metal arc welding there are all position welding. Here, electro slag is only vertical welding; you cannot do it in a horizontal mode, down hand mode, neither you can do it in a overhead mode, so, only vertical.

(Refer Slide Time: 10:49)

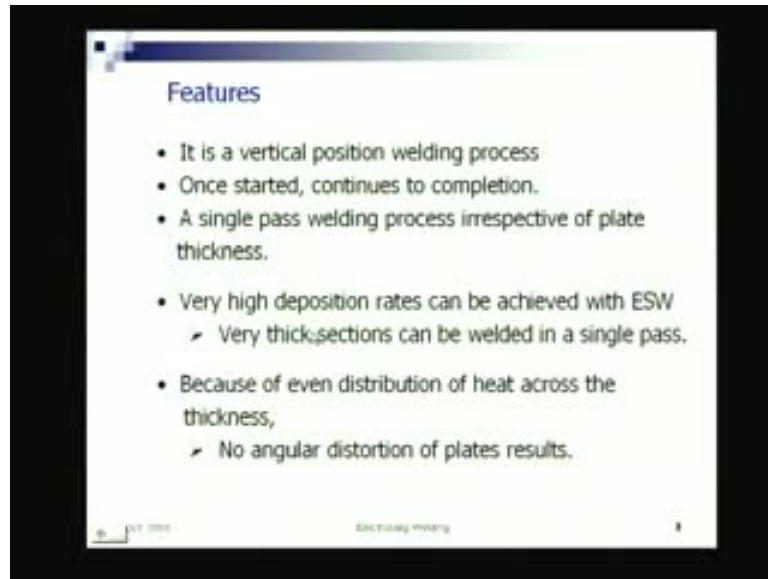

(Refer Slide Time: 11:07)

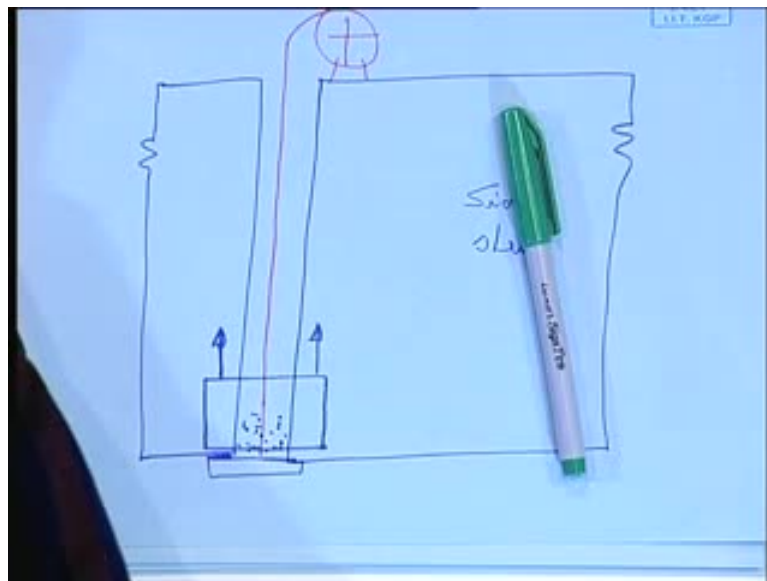

And also you can see once the process is started, it continues to completion that means, half way between you cannot stop and redo, restart. Well, if it stops, **how** why it should stop? If there is a short circuit, if there is a miss match of the moment of this shoes and the feeding of the electrode, they are the two things you will have to match. The shoes will go up and the electrode you will have to keep on feeding, because electrode is getting melted and deposited. It can be single electrode; it can be multiple electrodes, depending on how much deposition is needed.

(Refer Slide Time: 11:27)

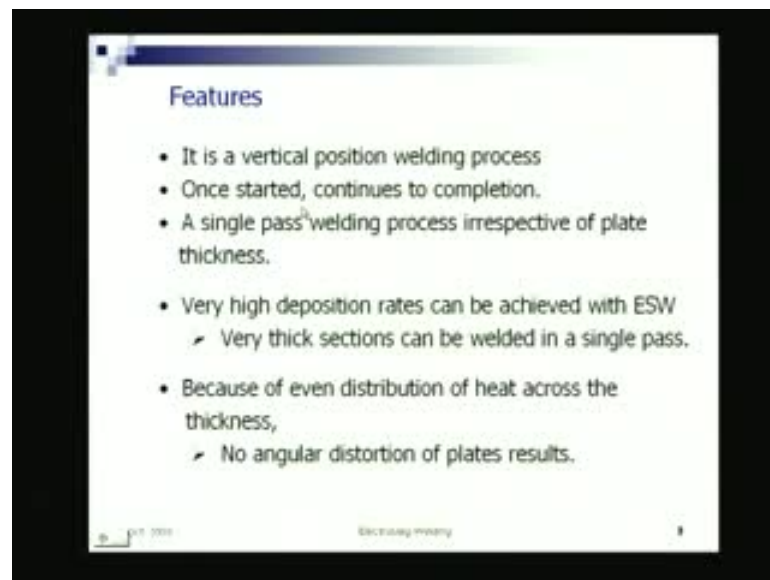

Features

- It is a vertical position welding process
- Once started, continues to completion.
- A single pass welding process irrespective of plate thickness.
- Very high deposition rates can be achieved with ESW
 - Very thick sections can be welded in a single pass.
- Because of even distribution of heat across the thickness,
 - No angular distortion of plates results.

© 2011 Electrical Engineering

(Refer Slide Time: 11:45)

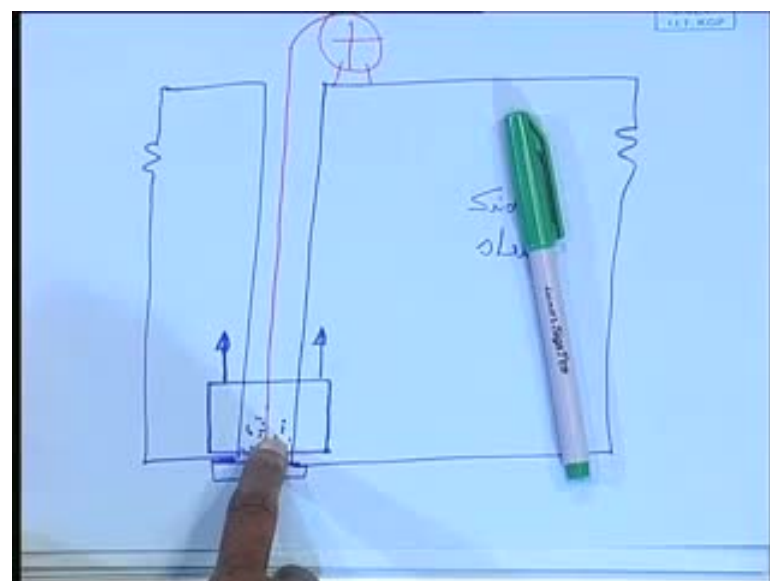

(Refer Slide Time: 11:48)

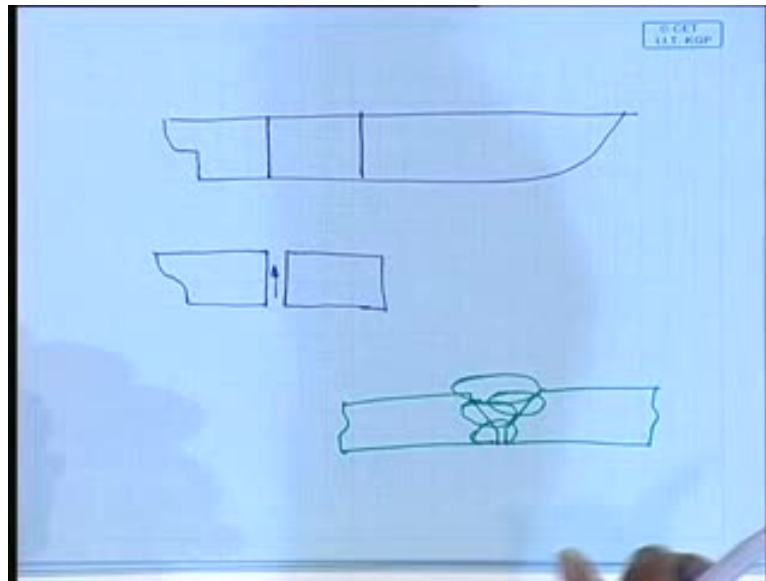

So, once started it continues to completion, a single pass welding process irrespective of plate thickness. What does that mean that means? It can virtually weld any thickness of plate at one go in a single pass with whole process is like that. In other conventional welding processes, say you are welding in a down hand position; a butt welding you are doing to flat plates; you are welding, you have a edge preparation like this.

(Refer Slide Time: 12:20)

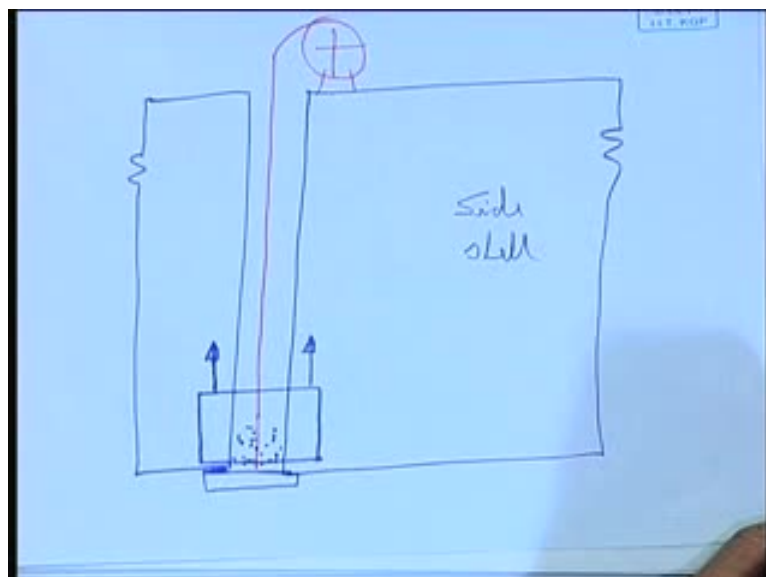

(Refer Slide Time: 12:31)

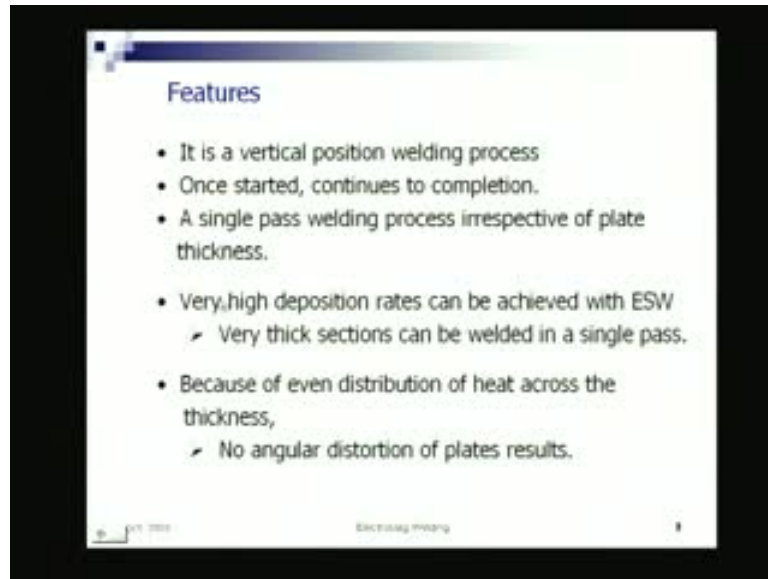

So, there may be a situation that in the first run, you deposit so much; in the second run, you deposit this much, third, and fourth, so many runs you give gradually, you fill it up, but here, it is not that way. In one single run, the entire thickness is fused, metal deposited, and welding is done. So, that is how it is a very high deposition rates can be achieved with this electro slag welding. Very thick sections can be welded in a single pass, by that, we mean, very thick sections means 80 millimeter, hundred millimeter plates can be welded at one run, one single run.

So, and also what happens because of even distribution of heat across the thickness, angular distortion of, there is no angular distortion, essentially angular distortion takes place because of uneven heat flow across the thickness. There is more heat at the top; less heat at the bottom, if you are welding from the top. But in this case, it is a vertical, two sides are being welded and equal heat distribution all around in that entire area, volumetric area, where you have the molten slag pool. So, there is no temperature, no gradient of heat, there may no temperature gradient across thickness, so, no distortion; that is also another advantage.

(Refer Slide Time: 13:44)

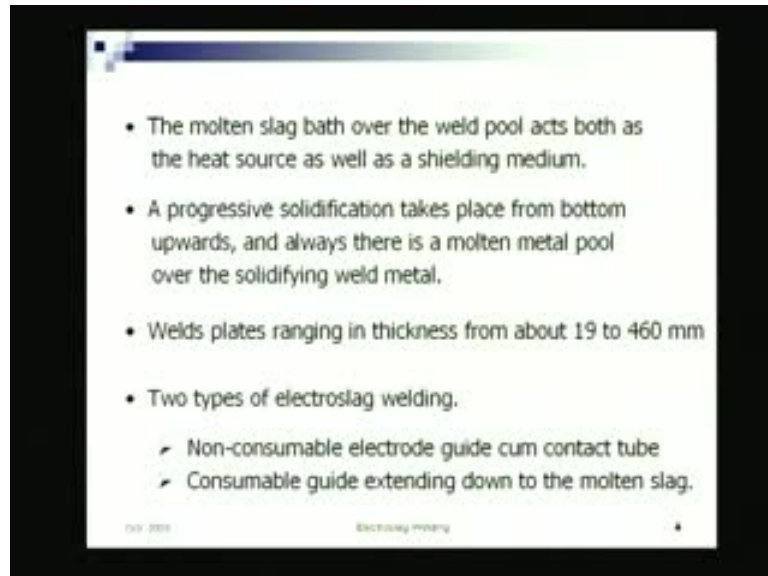

(Refer Slide Time: 13:52)

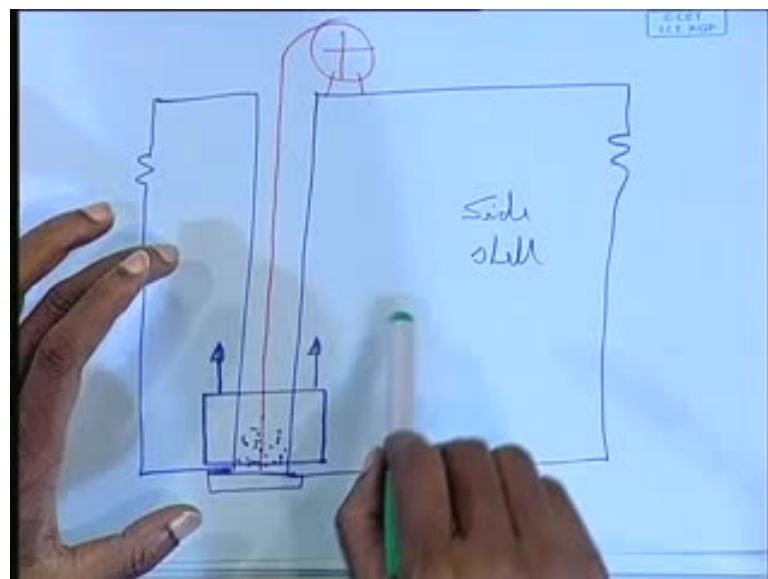

(Refer Slide Time: 14:20)

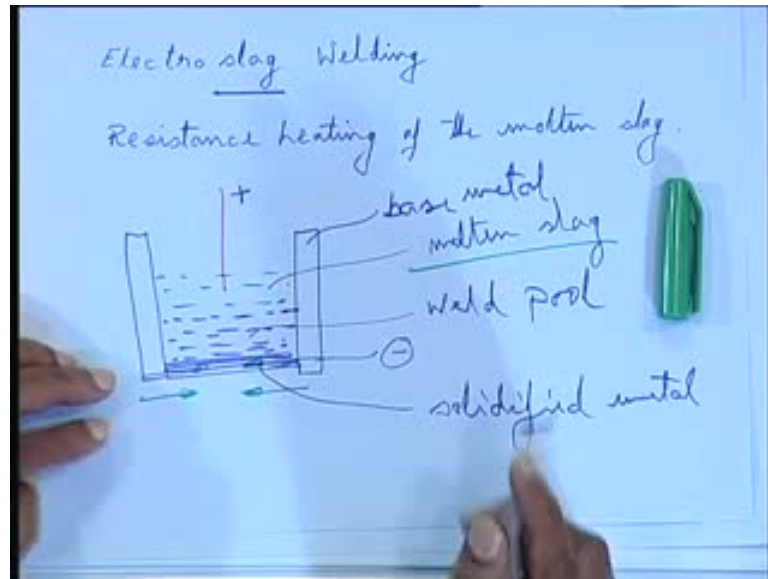

(Refer Slide Time: 14:49)

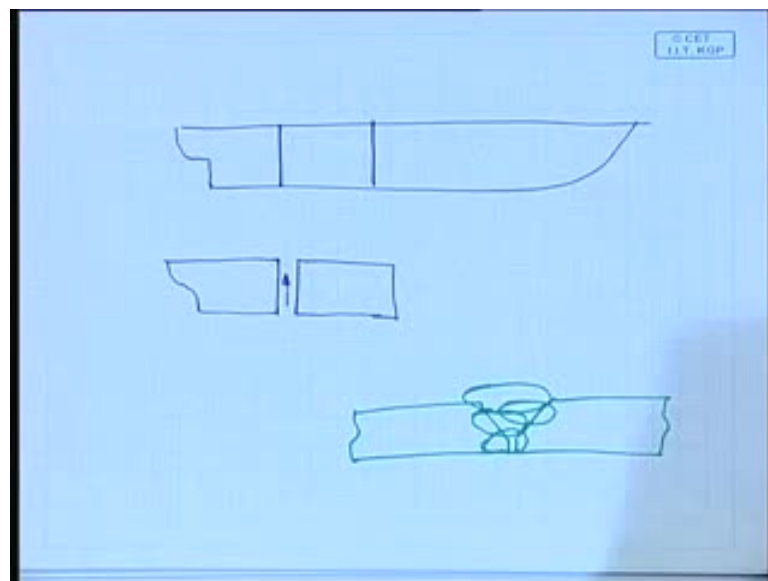

No, that is a different issue. Here, that does not happen. Here, that, because thing is firstly these type of welding are generally used in a thicker sections, and whether it will close up or open out, that again depends on the speed of the welding. The how fast the contractional forces are working, because as it is progressing up, your metal is getting solidified below, the metal is getting solidified below; as the metal is getting solidified, so the contractional forces will start working. So, they can give rise to a case of opening up, what you are mentioning? So, those precautions are taken, and here, actually, this welding will be on very heavy structures like I said two blocks. So, opening up is not

very much possible the plates are it restrained from that. So, those difficulties are not there.

(Refer Slide Time: 15:04)

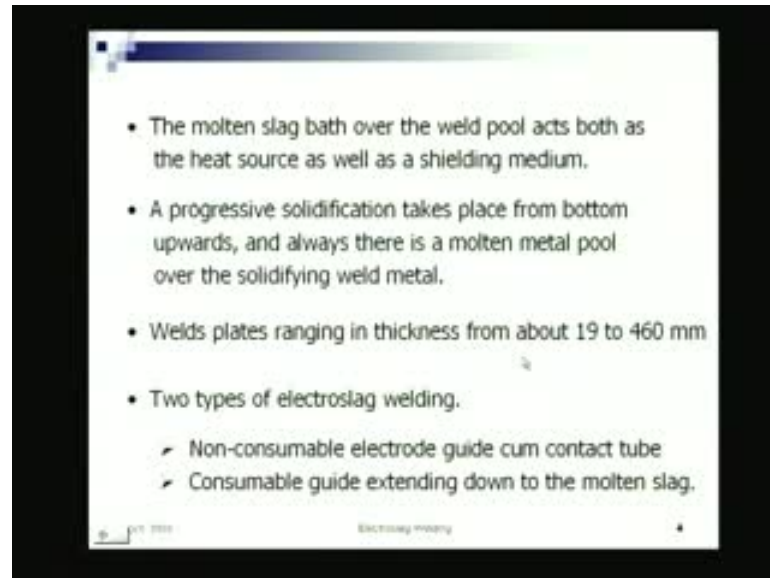

Well, the molten slag bath over the weld pool act as the heat source as well as the shielding medium. That molten slag bath, it provides a heat as well as shields the molten metal from oxidation. So, a progressive certification takes place from bottom up words. Welds plates ranging in thickness from about nineteen to 460 millimeter, why this figure for analysis? It is that such thick plates have been welded that is how. So, god knows, if a one meter thick plate has to be welded, I do not know whether it is feasible, but apparently, theoretically possible. 460 millimeter plate definitely not in ship build, building something else, probably nuclear reactor and all that, shielding things they do, possibly there.

(Refer Slide Time: 16:39)

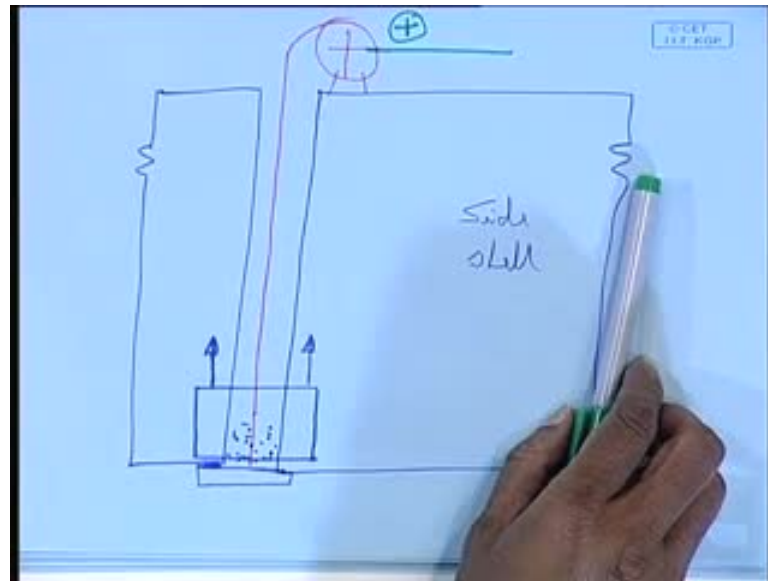

But as far as ships are concerned, one may encounter plate thicknesses of 80 millimeter, hundred millimeters like that, generally not beyond that as of now, but you can see a even a thickness of 460 millimeter, that means half a meter thick - this is the thickness not the breadth - half a meter thick plate, you are welding in one run, that is a terrible thing. Anyway, so, there is generally, this electro slag welding you have been two types. One can say depending on how you feed the electrode - one is a non-consume consumable electrode guide, another is a consumable electrode guide, that means you see the process is very simple, there is no, I mean, no complications as such a simple process, but there are engineering difficulties in it. First is to synchronize the lifting of this and feeding of the electrode. Second having these shoes, this pieces, they can be seen like pierce or can be copper shoes, water cooled which can hold the thing and also withstands the temperature of the molten metal.

That means it will be exposed to around 1500 odd degree centigrade and should be able to stick to the surface and slide up, and do not allow leakage of the slag, molten slag or the molten metal. Thus third is how do you assure, I mean how to assure feeding of the electrode? Because you see the power is fed here; power is not fed there, power is fed right at the top. So, the entire wire coming down, if it does not come down straight and touches either of the side, there will be short circuit. It will spark, there it will get cut, the wire will get, will burn out.

(Refer Slide Time: 18:23)

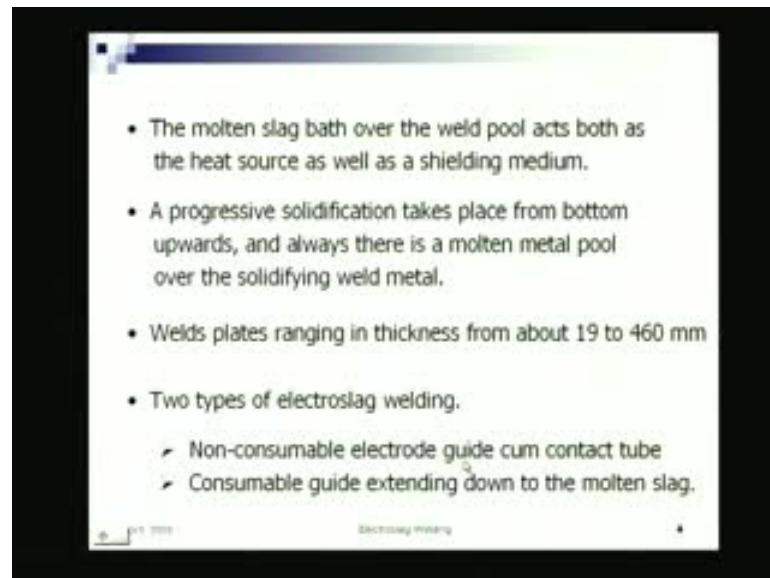

(Refer Slide Time: 18:23)

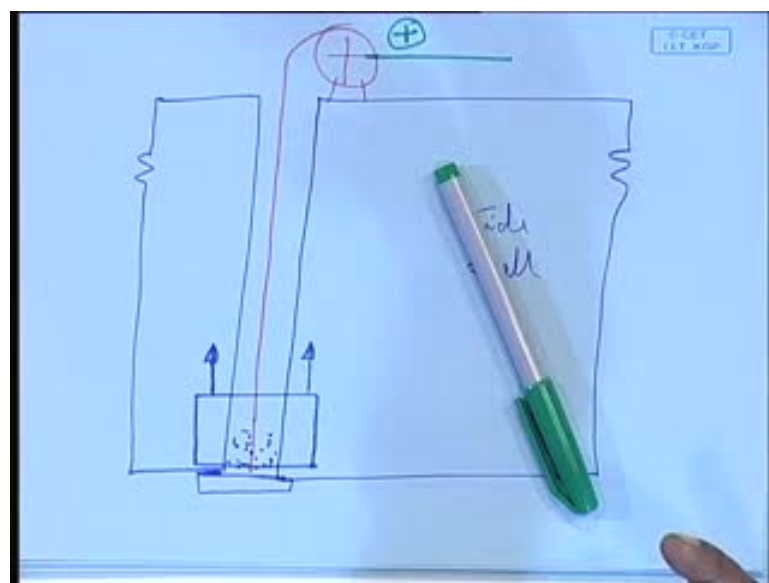

(Refer Slide Time: 18:44)

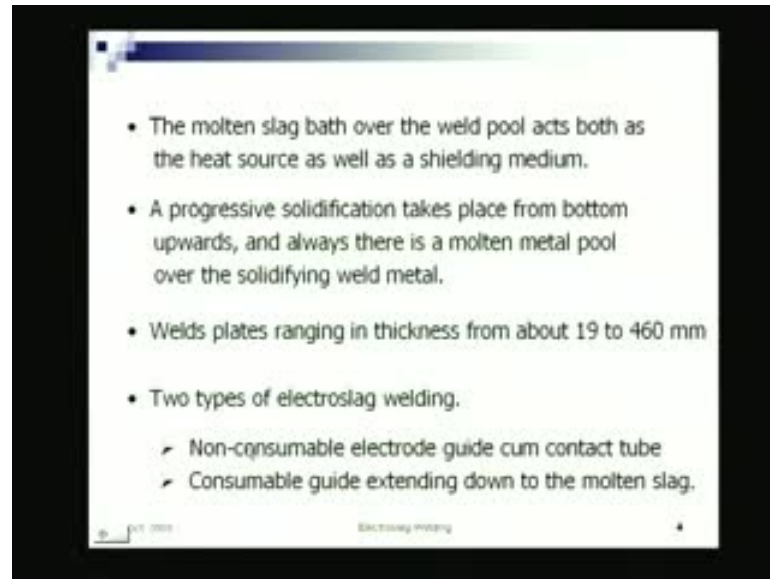

(Refer Slide Time: 18:54)

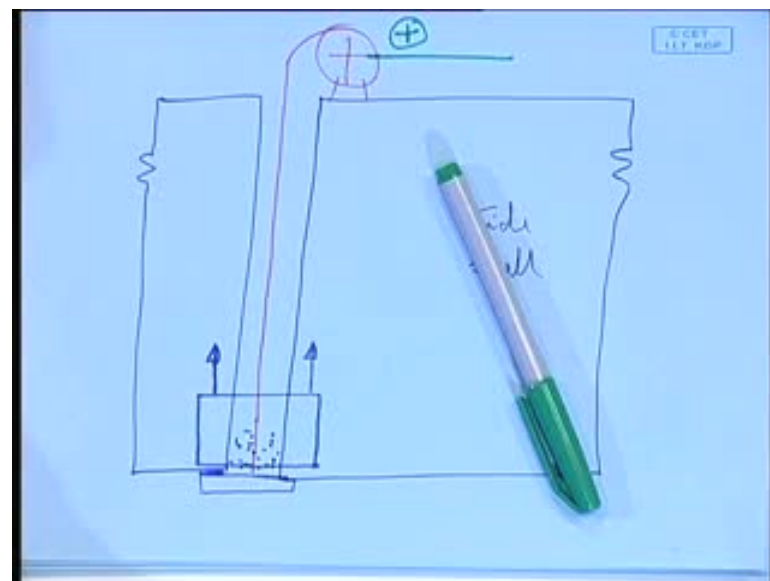

(Refer Slide Time: 18:59)

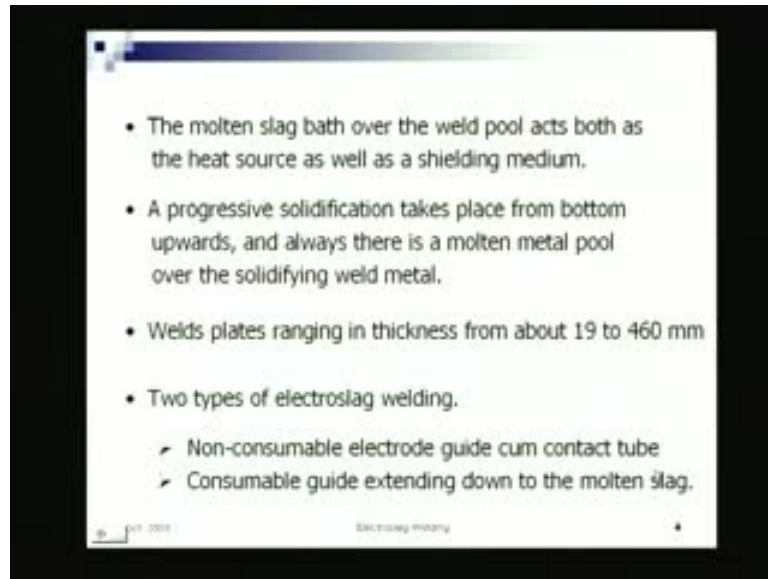

So, we will have to fit it vertical down without touching the plate surfaces. So, that is why you have some kind of guide through which you send the wire down. This height as you can see can be very high, it can be 10 meters; it can be 20 meters for big ships. For example, the depth of the ship, that much would be the height. So, that is why you need a suitable guide, which will, I mean which will help you to guide the wire electrode down to the molten pool. So, you have non-consumable electrode guide cum contact tube or consumable guide extending down to the molten slag.

(Refer Slide Time: 19:04)

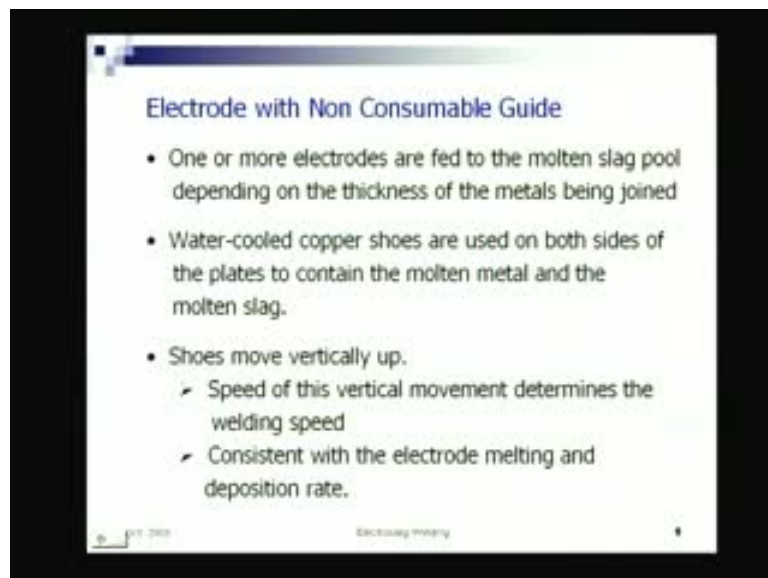

(Refer Slide Time: 19:31)

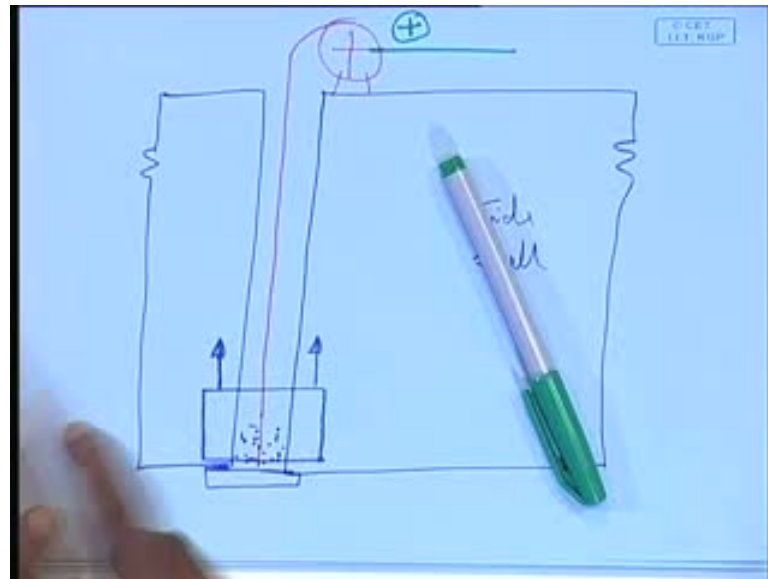

(Refer Slide Time: 19:38)

Electrode with Non Consumable Guide

- One or more electrodes are fed to the molten slag pool depending on the thickness of the metals being joined
- Water-cooled copper shoes are used on both sides of the plates to contain the molten metal and the molten slag.
- Shoes move vertically up.
 - Speed of this vertical movement determines the welding speed
 - Consistent with the electrode melting and deposition rate.

© 2018 Electrode welding

(Refer Slide Time: 19:46)

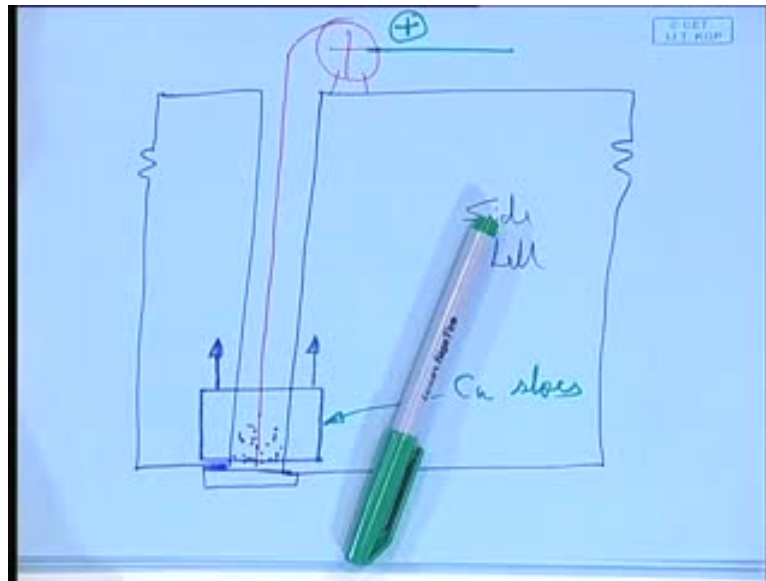

So, electrode with non-consumable guide, what is it here? One or more electrodes are fed to the molten slag pool depending on the thickness of metals to be joined. Definitely, if higher thickness you may need multiple electrode, lesser thickness probably one electrode would be enough. That one can find out what is the deposition rate required. Deposition rate is nothing but what is the volume? What is the feeding rate? So much of metal to should get melted and deposited. So, water cooled copper shoes are used on both sides; these are the water cooled copper shoes; these are the on both sides of the plate to contain the molten metal and the slag.

(Refer Slide Time: 19:57)

Electrode with Non Consumable Guide

- One or more electrodes are fed to the molten slag pool depending on the thickness of the metals being joined
- Water-cooled copper shoes are used on both sides of the plates to contain the molten metal and the molten slag.
- Shoes move vertically up.
 - Speed of this vertical movement determines the welding speed
 - Consistent with the electrode melting and deposition rate.

© 2008 Electrode welding

Shoes moves vertically up. The speed of this vertical movement determines the speed. So, here the welding speed, so, here the welding speed is speed of the movement of that shoe because as the shoe goes up the metal below get solidified.

(Refer Slide Time: 20:28)

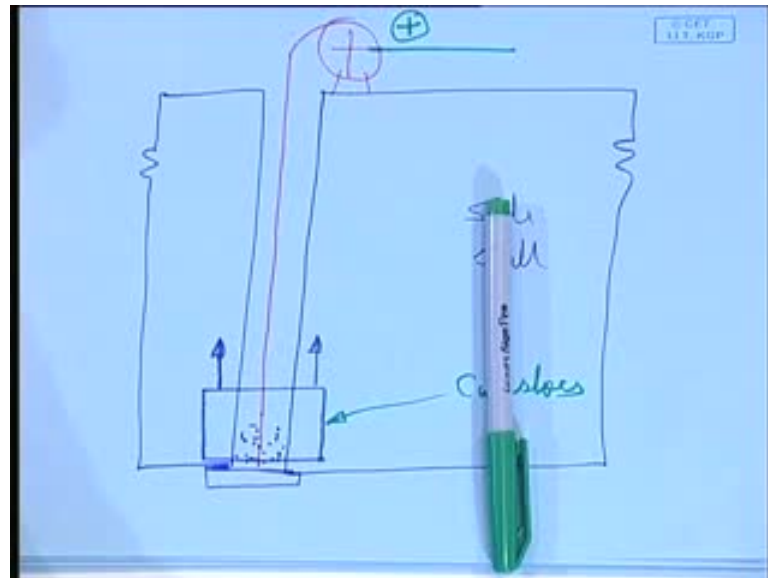

(Refer Slide Time: 20:34)

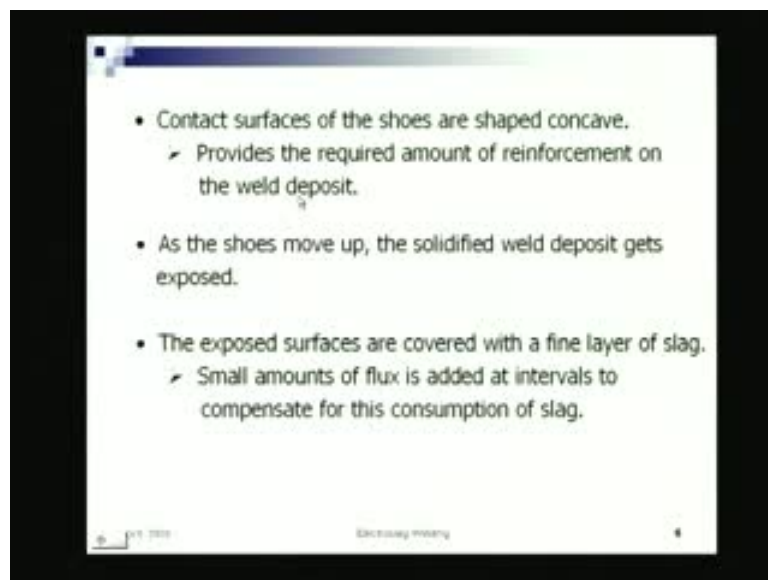

(Refer Slide Time: 20:46)

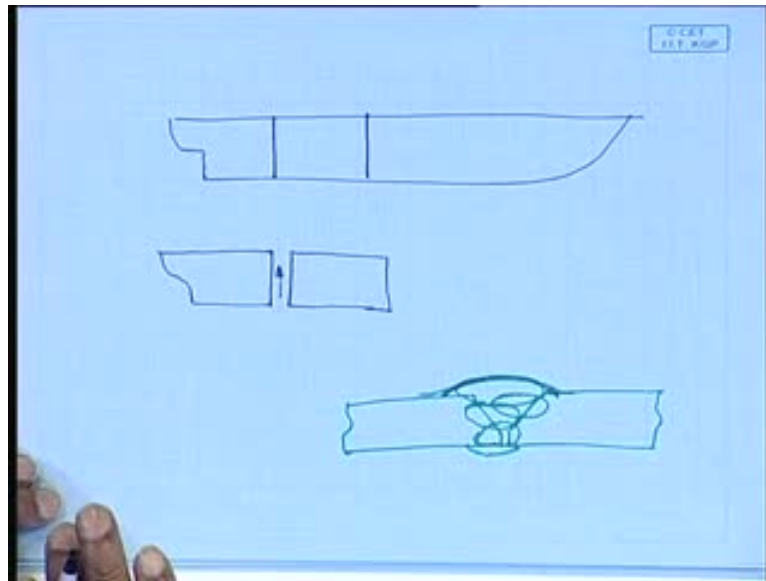

So, consistent with the electrode melting and deposition rate should be the shoe going up should be consistent with that. That means it should match. As I was saying, the shoe going up and the electrode getting fed, they should match, they should be consistent with each other contact surfaces of shoes are shaped concave. Well, that provides the required amount of reinforcement of the weld deposit because whenever you do welding, as you know, you provide a concave surface at the end, sorry, a convex surface, that means there is a reinforcement.

(Refer Slide Time: 20:57)

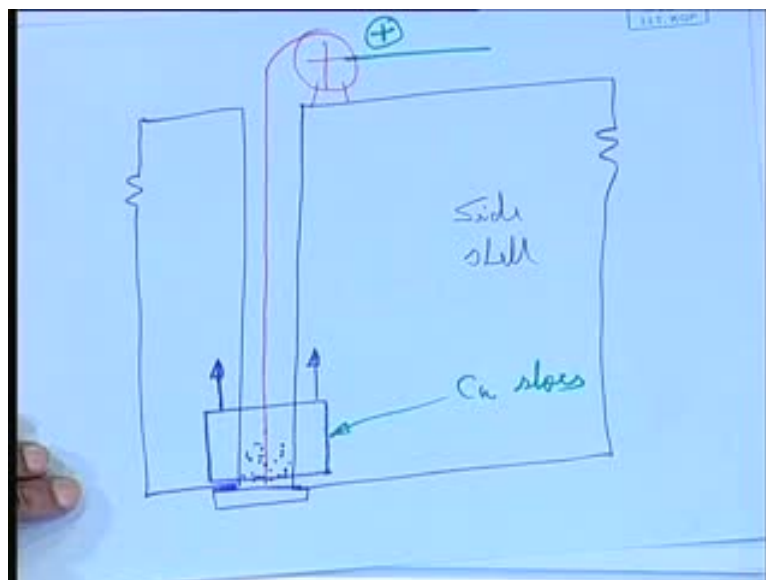

(Refer Slide Time: 21:13)

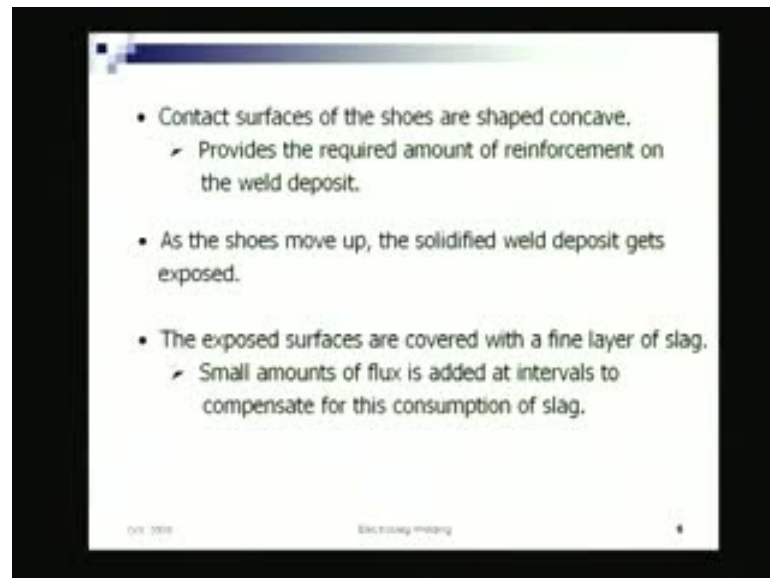

(Refer Slide Time: 21:33)

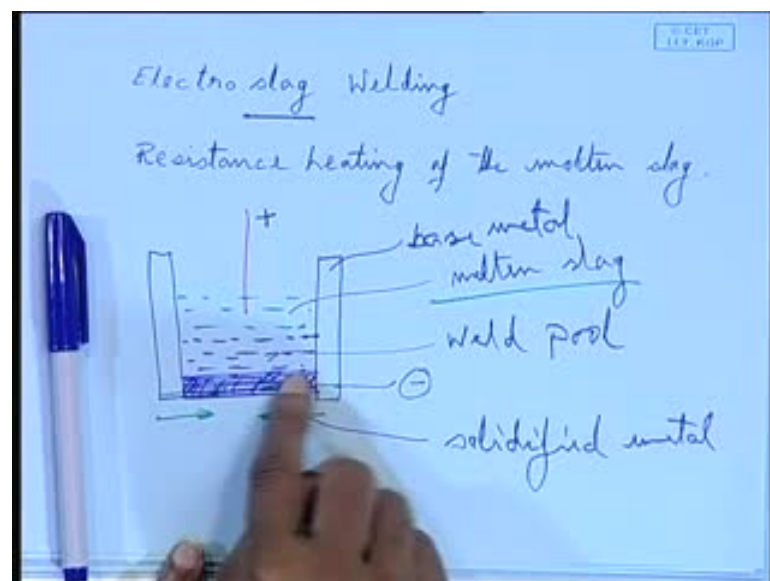

(Refer Slide Time: 22:19)

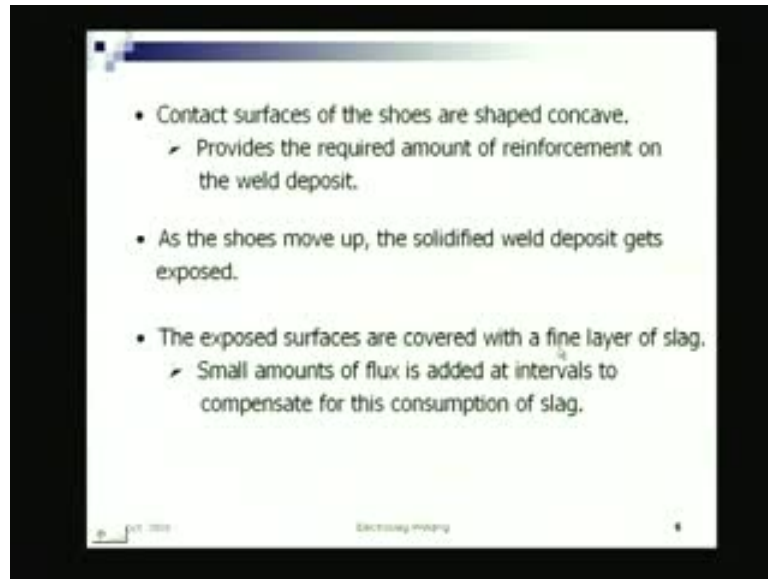

So, this shoes, whatever I have used, inside they have a little concave surface, such that, it supports that molten metal and forms a nice bead, a weld bead. So, as the shoes move up, solidified weld deposit gets exposed. The exposed surfaces are covered with fine layer of slag. **Small amounts of** So, what do you see is as it goes up, the molten, the solidified metal as schematically we are showing here so called solidified metal gets exposed and it remains covered with a fine layer of flux, fine layer of slag, because otherwise as you can see in all the welding even in submerged arc welding process, a part of the flux is getting burnt, and it is forming a slag that is being removed. So, you will have to continuously keep on adding flux in the process, but here, once you put the flux, no more flux is getting consumed because only that much is remaining that entire molten slag is going up, but in reality what happens, some of the there is always a fine layer of slag sticks to the weld deposit the molten metal.

(Refer Slide Time: 22:38)

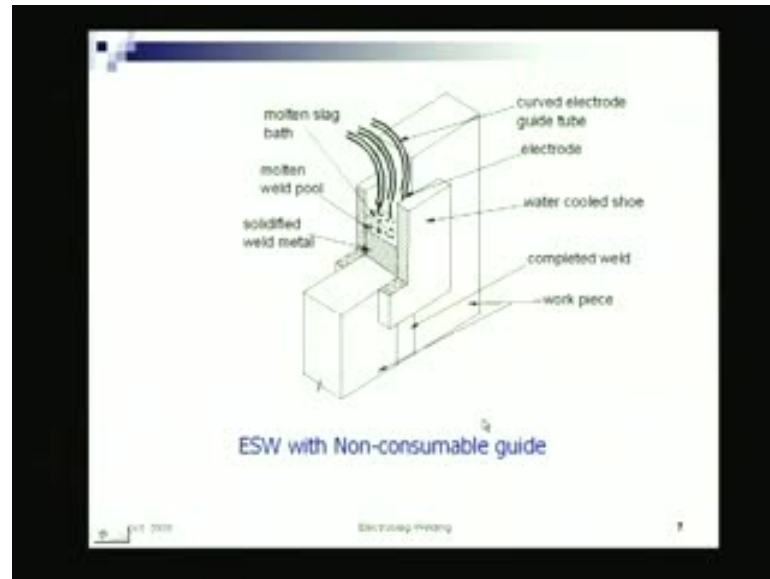

So, small amounts of flux are added at an interval to compensate for the consumption, or in other words, the flux consumption is very nominal. So, these are schematic of the process.

(Refer Slide Time: 22:45)

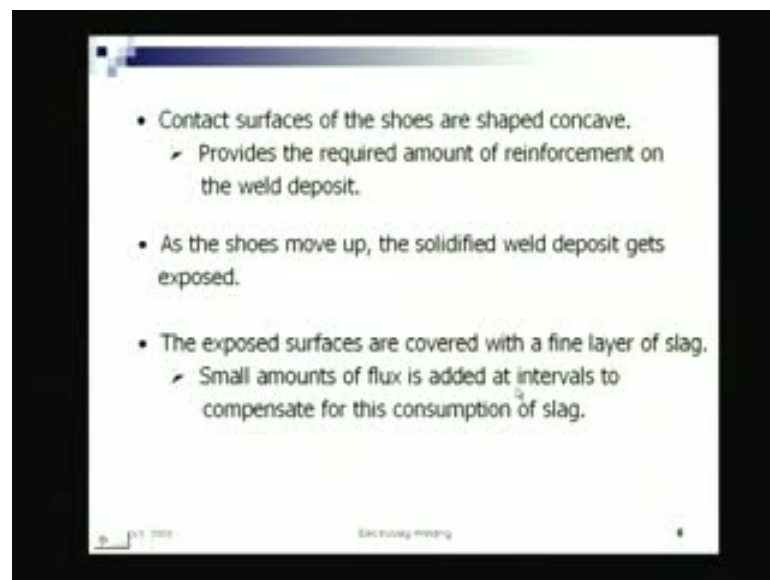

What is happening is once you put the flux that same flux continues till you reach the top then you throw it off, or that means only that much is consumed. Theoretically only that much, but in reality what happens, that means, in that case, it does not, it do not need to put extra flux in the during the welding process. For example, any other welding, say gas

metal arc welding, you have to continuously inject CO₂ or argon or helium. When we are doing submerged arc welding through hopper, you will have to continuously pour flux. Once the welding is over, the flux which is lying on top of the slag which is not melted, you recycle back.

(Refer Slide Time: 23:48)

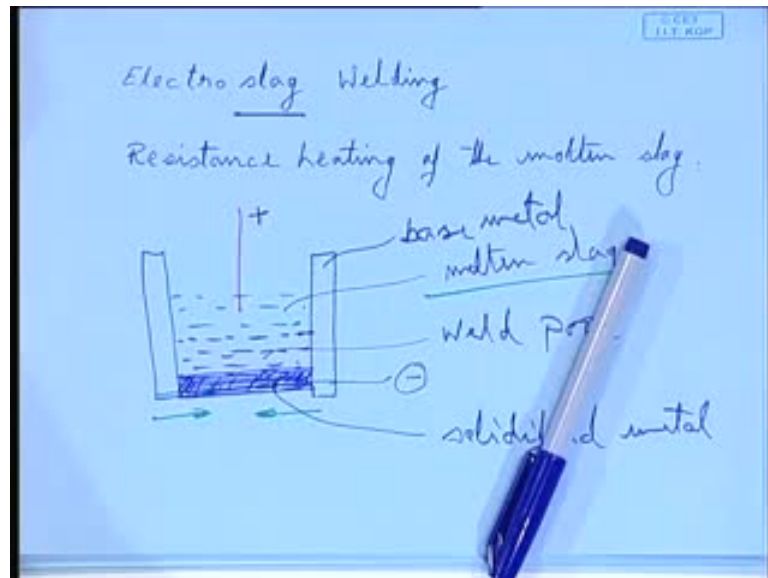

(Refer Slide Time: 23:59)

- Contact surfaces of the shoes are shaped concave.
 - Provides the required amount of reinforcement on the weld deposit.
- As the shoes move up, the solidified weld deposit gets exposed.
- The exposed surfaces are covered with a fine layer of slag.
 - Small amounts of flux is added at intervals to compensate for this consumption of slag.

(Refer Slide Time: 24:14)

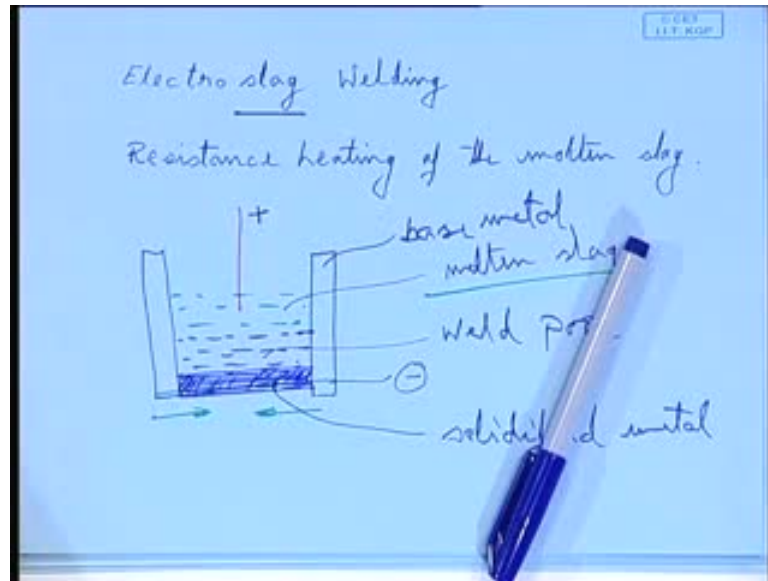

But rest has got burnt, you have to throw that. That means again you do a next plate, you have to add additional flux, flux is getting consumed. Here, flux is not getting consumed, what you have started with that continues through the whole process. But what in reality happens is little bit is consumed, why? Because some amount of flux sticks to the exposed surface; sticks to the molten metal, I mean the solidified metal. So, little addition of flux is needed, I mean it is not a serious issue. It is only what it says that what should be the welding consumable? How much is consumed? The filler wire is consumed that gets deposited and much less amount of flux is consumed; that is a main thing.

(Refer Slide Time: 24:31)

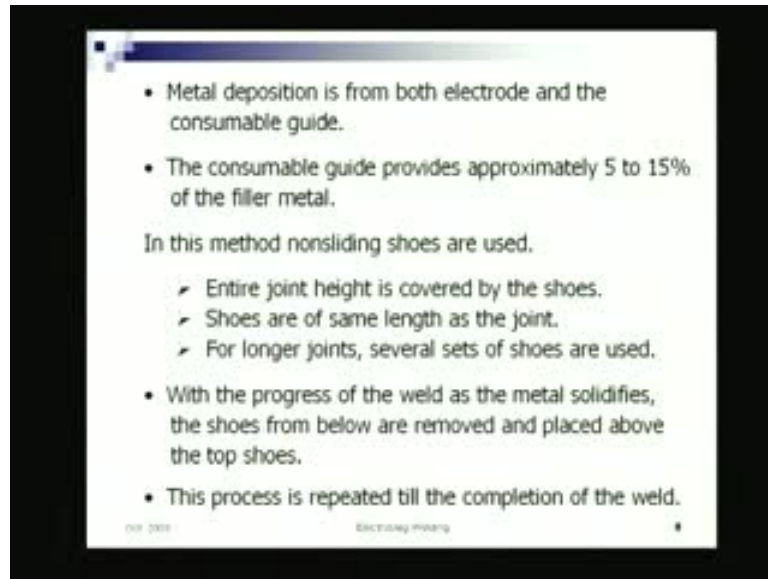

So, here we have talked about metal deposition, I mean when you use a consumable guide - consumable guide means what? The guide tube also gets consumed means also gets melted and deposited. So, that is what it says that the deposition is from both electrode as well as the guide. Here, it provides additional 5 to 15 percent of filler metal.

(Refer Slide Time: 25:20)

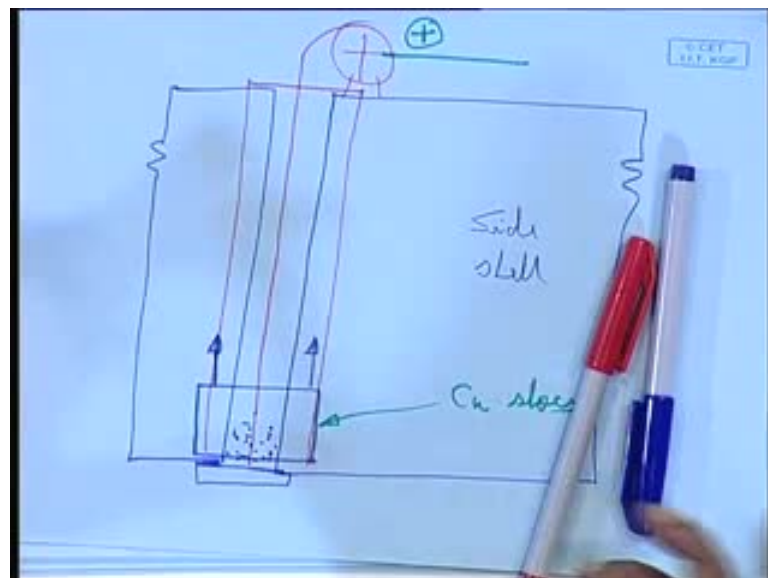

(Refer Slide Time: 24:40)

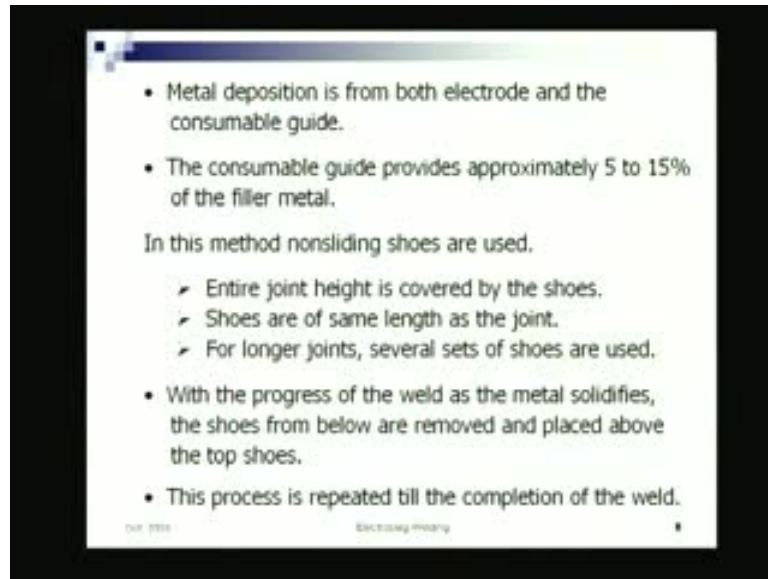

So, in case of this, one can have even non-sliding shoes, that mean the entire side is covered. You assume that this entire thing, if I have a mechanism by which I put a cover to the entire side. Then it becomes even easier, I do not have to make a mechanism by which I will have to slide the things up, but they had the entire joint height is covered by the shoes. Shoes are of the same length that of the joint. For longer joints several sets of shoes can be used. With the progress of weld, as the metal solidifies, the shoe from the below are removed and placed on top.

(Refer Slide Time: 26:04)

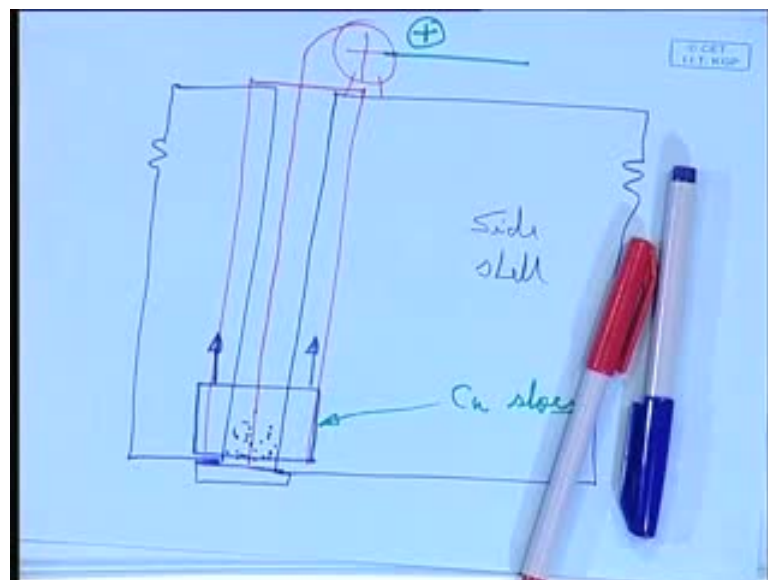

Removing it and putting in top like that. Instead of having a sliding mechanism, it is kind of as if you are fixing it to the surface. You just remove and put on top. Anyway, it sounds simpler and easier, but in reality, the sliding business is better more effective.

(Refer Slide Time: 26:24)

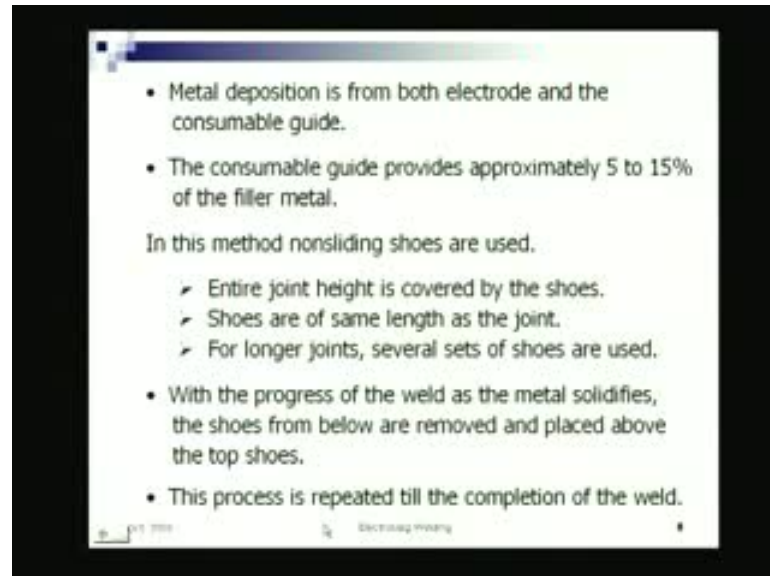

• Metal deposition is from both electrode and the consumable guide.

• The consumable guide provides approximately 5 to 15% of the filler metal.

In this method nonsliding shoes are used.

- Entire joint height is covered by the shoes.
- Shoes are of same length as the joint.
- For longer joints, several sets of shoes are used.

• With the progress of the weld as the metal solidifies, the shoes from below are removed and placed above the top shoes.

• This process is repeated till the completion of the weld.

26:24 26:24

(Refer Slide Time: 26:30)

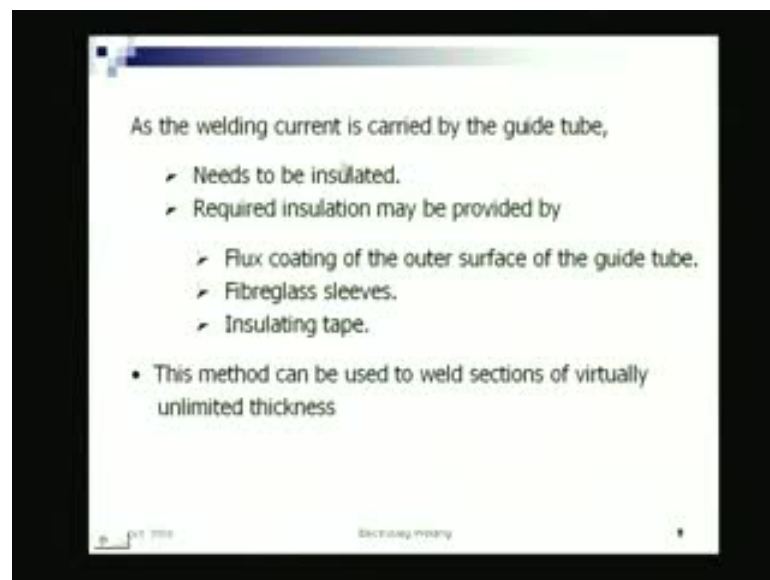

As the welding current is carried by the guide tube,

- Needs to be insulated.
- Required insulation may be provided by
 - Flux coating of the outer surface of the guide tube.
 - Fibreglass sleeves.
 - Insulating tape.

• This method can be used to weld sections of virtually unlimited thickness

26:30 26:30

(Refer Slide Time: 26:59)

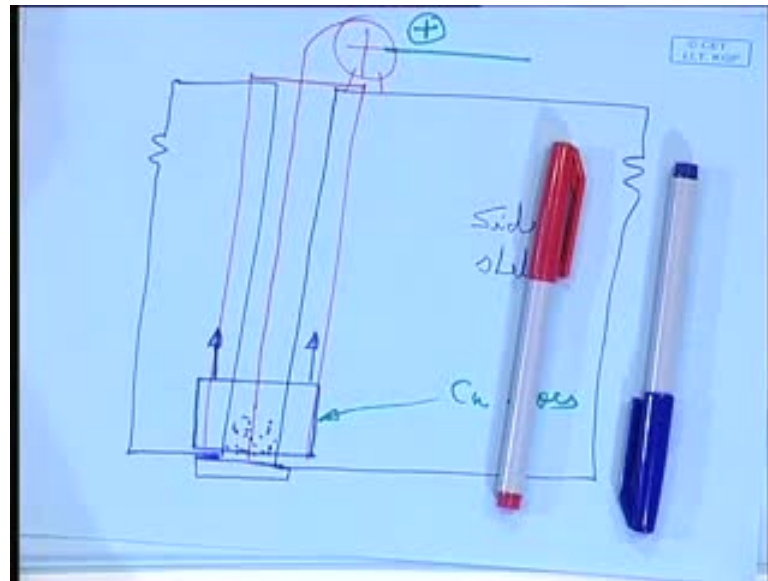

The process is repeated till completion. As the welding current is carried by the guide tube, it needs to be insulated. Required insulation may be provided by flux coating on the outer surface, fiberglass sleeve or insulating tape. This is a complicated business, because that consumable guide - consumable guide means what? The guide which is supporting the feeder electrode, and the guide tube also it is providing a support but it also gets melted and deposited.

(Refer Slide Time: 27:22)

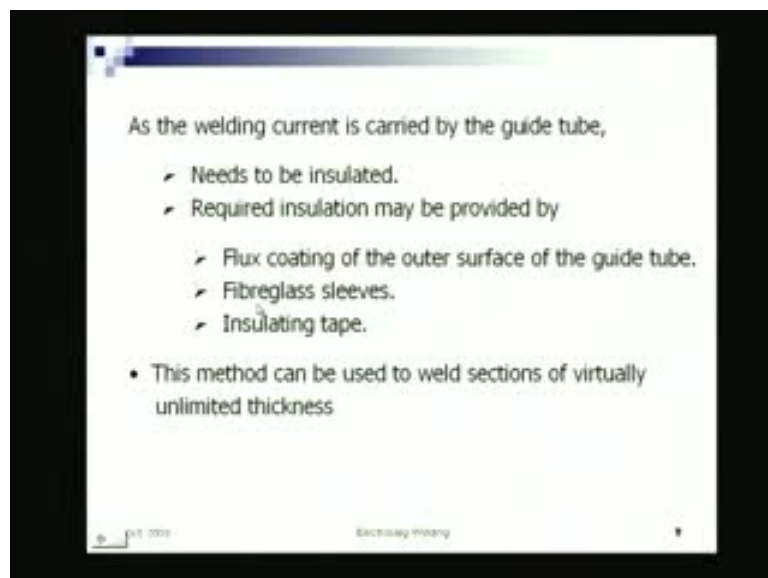

So, that means, that is also a metal. So, if the, and it is guiding through this that means, that guide tube again should not touch this. So, you will have to properly insulate. To ensure that even if touches, nothing happens. Now, if you insulate with a fiber glass sleeve, then what happens to that sleeve? Where it goes? It should melt and should float up as a dross; it cannot go in the molten metal, is not it, or any insulating tape if I use, the tape should burn out and float out in the slag, as a dross, as a impurity in the slag, and also should not generate any un-due fumes or gases which may get entrapped.

So, that is why one of the best ways would be a kind of a flux coating if it can be provided. Flux coating means, like you have in case of manual electrodes, you have a flux coating there, some such thing, such that, that will that will add to the slag bath. In any case, the idea is a required insulation has to be provided.

(Refer Slide Time: 28:29)

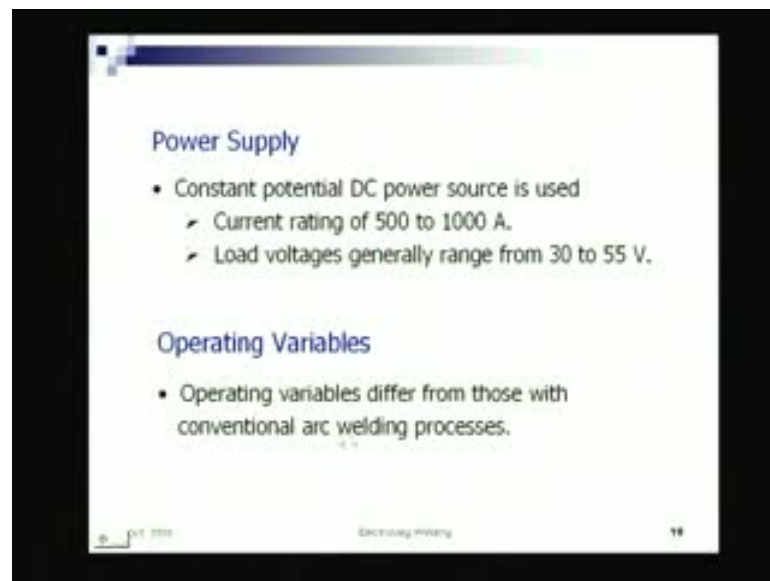

This method can be used to weld sections of virtually unlimited thickness, any thickness can be welded. Well, other features are power supply here; generally you use a constant potential DC power source current ranging from 500 to 1000 ampere. Load this voltages generally arc voltage essentially 30 to 35 volt and the operating variables differ from those of conventional welding processes.

(Refer Slide Time: 28:56)

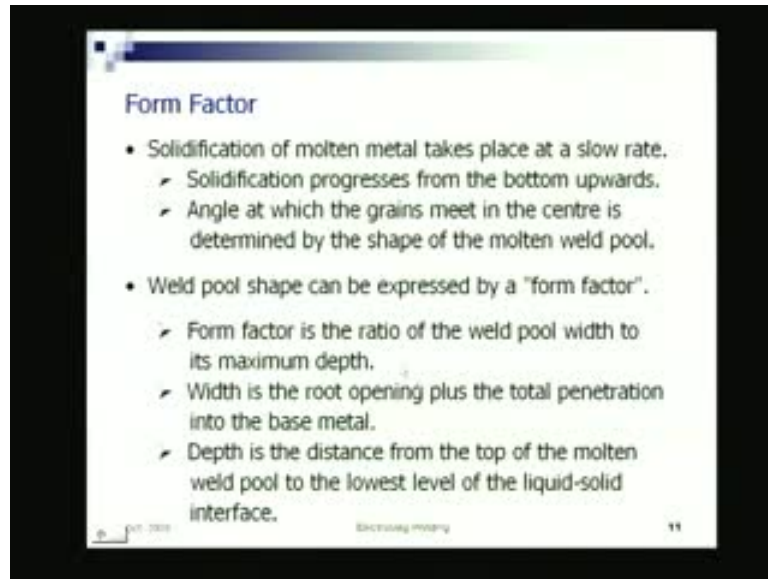

There is something called form factor which in this aspect was not there in the other welding processes. Form factor is the solidification of molten metal takes place at a slow rate. In this particular process, the solidification is very slow because the **slowly that solidification rate is basically the welding speed rate here** because slowly the shoes are going up, so, then only it is getting solidified. If the shoe does not move, it will not solidify because the heat is continuously there.

So, solidification progresses from bottom upwards angle at which grains meet in the centre is determined by the shape of the molten pool. We had been talking about the grains which are after the welding you have a columnar grain pointing upwards or pointing inwards.

So, that is what we have talked about here angle at which the grains meet in the centre is determined by the shape of the molten weld pool. Weld pool shape is expressed by this form factor, I mean how the grains will form, will meet at the centre will be determined by the solidification pattern and that is dependent on the shape of the weld pool.

(Refer Slide Time: 30:56)

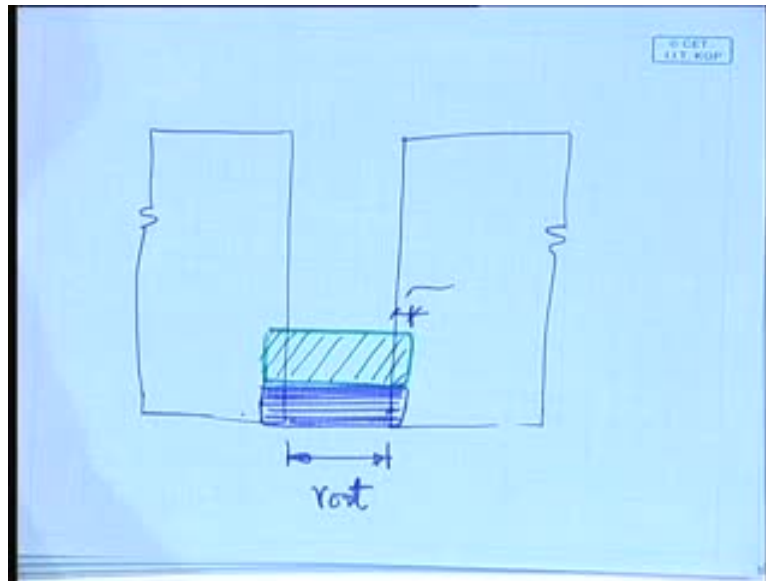

So, form factor is the ratio of the weld pool with which maximum depth. We will see that what is that is width is the root opening plus the total penetration in the base metal. **may be** Say these are the 2 vertical plates being welded, and let us assume that, well, here you have the molten pool is something like this, and here, below you have the solidified metal. This is the metal has solidified. So, what I have drawn is this is the root opening, the so called root opening, the root gap similar to that of butt welding, it is a case of butt welding only in a vertical position and this much is the fusion in the parent metal.

(Refer Slide Time: 32:10)

Form Factor

- Solidification of molten metal takes place at a slow rate.
 - Solidification progresses from the bottom upwards.
 - Angle at which the grains meet in the centre is determined by the shape of the molten weld pool.
- Weld pool shape can be expressed by a "form factor".
 - Form factor is the ratio of the weld pool width to its maximum depth.
 - Width is the root opening plus the total penetration into the base metal.
 - Depth is the distance from the top of the molten weld pool to the lowest level of the liquid-solid interface.

(Refer Slide Time: 32:17)

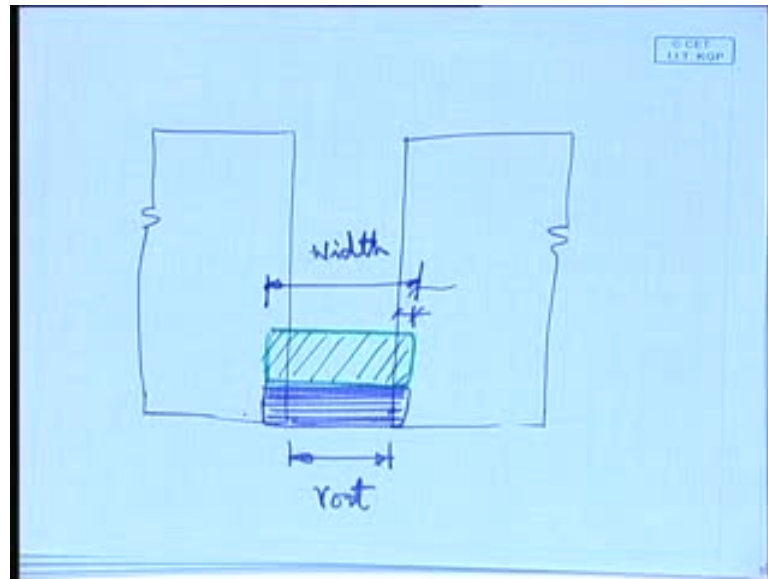

(Refer Slide Time: 32:33)

Form Factor

- Solidification of molten metal takes place at a slow rate.
 - Solidification progresses from the bottom upwards.
 - Angle at which the grains meet in the centre is determined by the shape of the molten weld pool.
- Weld pool shape can be expressed by a "form factor".
 - Form factor is the ratio of the weld pool width to its maximum depth.
 - Width is the root opening plus the total penetration into the base metal.
 - Depth is the distance from the top of the molten weld pool to the lowest level of the liquid-solid interface.

© 2011 Electronics Ministry 11

(Refer Slide Time: 32:38)

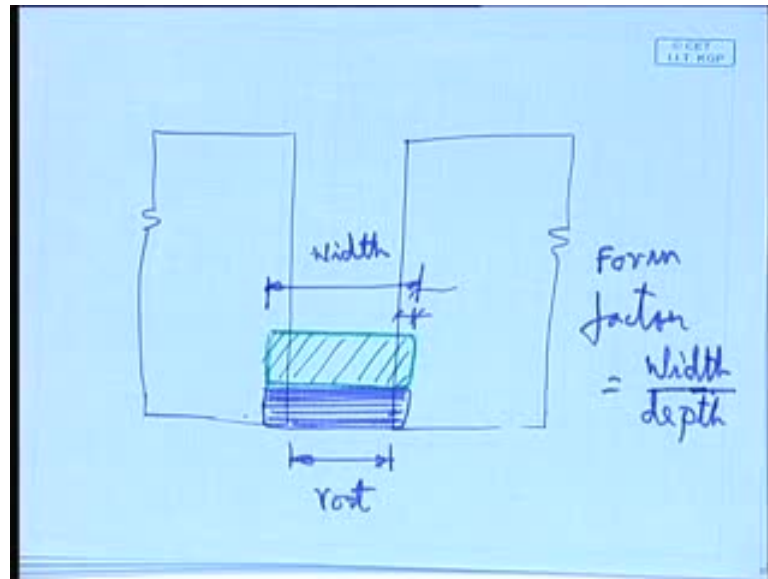

(Refer Slide Time: 32:56)

Form Factor

- Solidification of molten metal takes place at a slow rate.
 - Solidification progresses from the bottom upwards.
 - Angle at which the grains meet in the centre is determined by the shape of the molten weld pool.
- Weld pool shape can be expressed by a "form factor".
 - Form factor is the ratio of the weld pool width to its maximum depth.
 - Width is the root opening plus the total penetration into the base metal.
 - Depth is the distance from the top of the molten weld pool to the lowest level of the liquid-solid interface.

© IIT 2010 Electrowig mixing 11

(Refer Slide Time: 33:10)

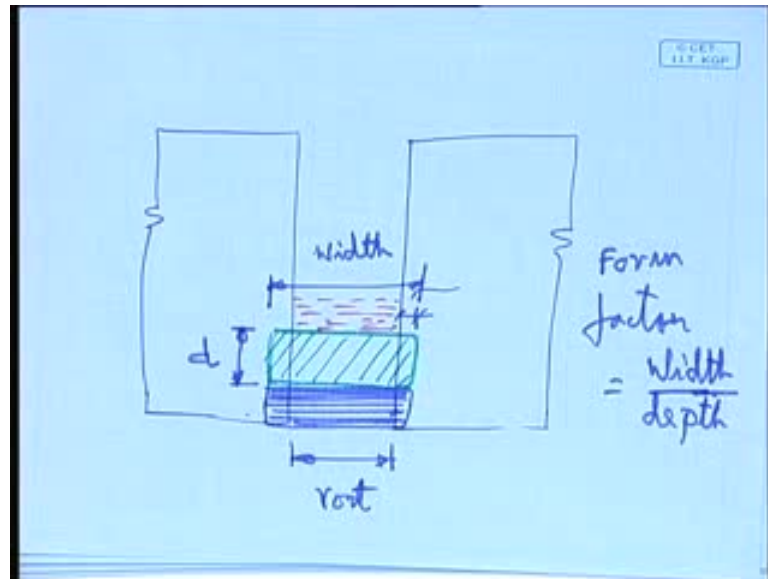

There is a fusion within the parent metal. So, form factor, so, what it says that width is the root opening plus the total penetration in the base metal. So, this is my total width, total width of the deposited metal, I mean of the fused metal basically and the depth because we have said that the form factor. Form factor is the ratio of the width to the depth. It is the ratio of this width to the depth. Depth is what? It is the distance from the top of the distance from the top of the molten weld pool to the lowest level of the liquid solid interface; distance from the top of the molten weld pool to the solid liquid interface, this is my depth, and on top of this you have the, of course, the molten slag.

(Refer Slide Time: 33:38)

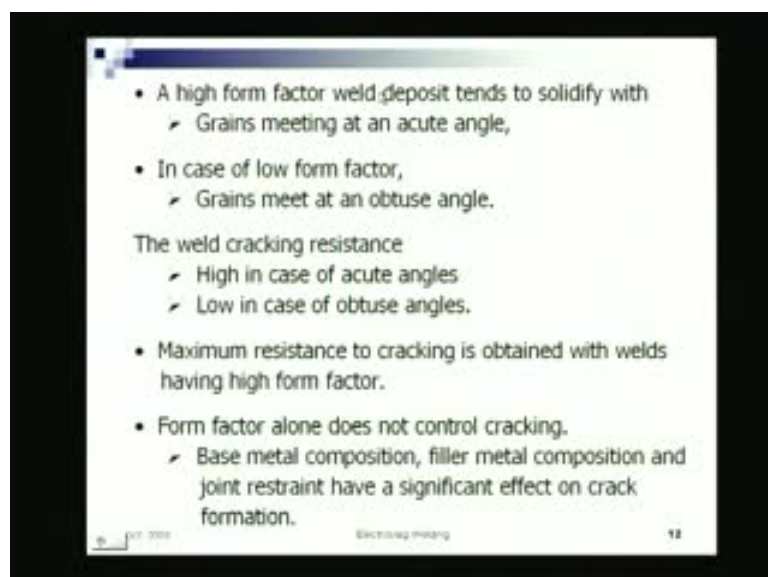

(Refer Slide Time: 33:55)

Form Factor

- Solidification of molten metal takes place at a slow rate.
 - Solidification progresses from the bottom upwards.
 - Angle at which the grains meet in the centre is determined by the shape of the molten weld pool.
- Weld pool shape can be expressed by a "form factor".
 - Form factor is the ratio of the weld pool width to its maximum depth.
 - Width is the root opening plus the total penetration into the base metal.
 - Depth is the distance from the top of the molten weld pool to the lowest level of the liquid-solid interface.

10/1/2008 Electronics meeting 11

(Refer Slide Time: 34:05)

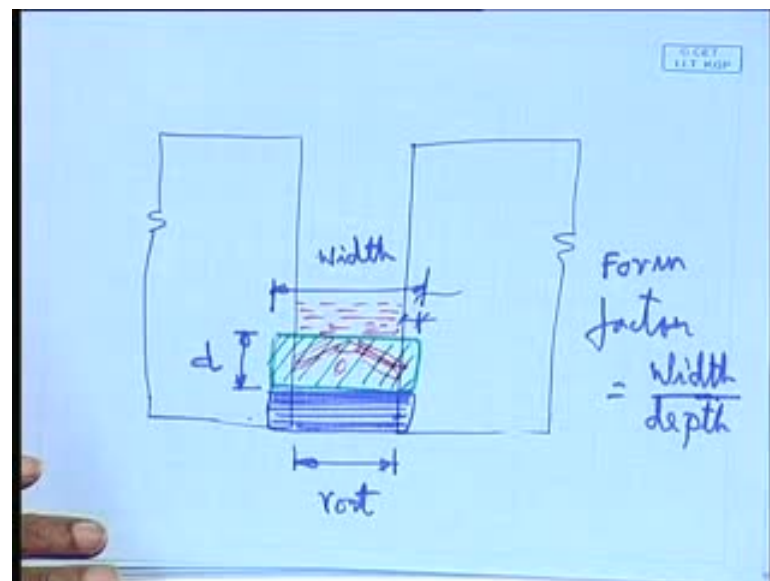

So, this width divided by this depth is the form factor. So, what do we see a high form factor tends to solidify with grains meeting at an acute angle - obtuse angle acute angle - because here, the grains, they tend to meet, as you see the solidification progresses, the angle at which the grains meet in the centre. The angle at which the grains meet because here the molten metal, when it is getting solidified, the grains will form in this fashion. So, this angle, at which they are meeting, the grains are forming; this angle, at which they are meeting, that is determined by the form factor.

(Refer Slide Time: 34:36)

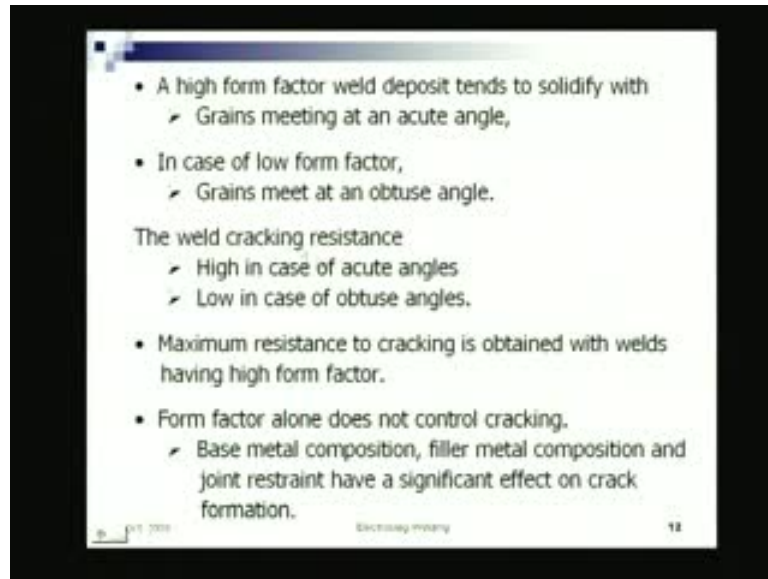

So, what do you see that a high form factor. High form factor means width is more depth is less will meet an acute angle. Otherwise, it will meet an obtuse angle. Now, what is the effect? The weld cracking resistance is high in case of acute angle; low in case of obtuse angle that is what. That means, so, what we see from that that maximum resistance to cracking is obtained with welds having high form factor, that means when you design the joint geometry, when you design this, that, how much should be the root gap? What is the thickness of the thing? What is the deposition rate? Because I can have a three electrodes simultaneously welding; I can have two electrodes submitted to welding; I can use 1000 ampere; I can use 500 ampere; different combinations are possible.

(Refer Slide Time: 35:41)

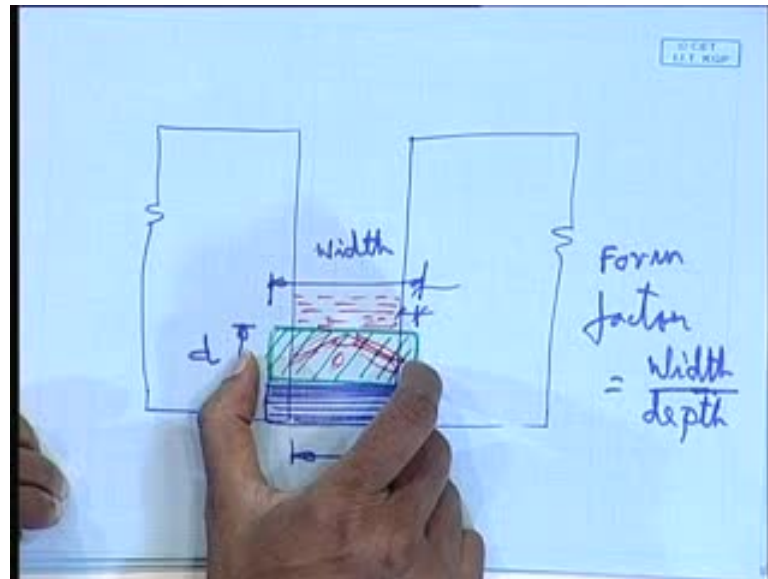

(Refer Slide Time: 35:53)

Form Factor

- Solidification of molten metal takes place at a slow rate.
 - Solidification progresses from the bottom upwards.
 - Angle at which the grains meet in the centre is determined by the shape of the molten weld pool.
- Weld pool shape can be expressed by a "form factor".
 - Form factor is the ratio of the weld pool width to its maximum depth.
 - Width is the root opening plus the total penetration into the base metal.
 - Depth is the distance from the top of the molten weld pool to the lowest level of the liquid-solid interface.

© 2010 Pearson Education, Inc. All rights reserved. Electronics Technology 11

(Refer Slide Time: 36:12)

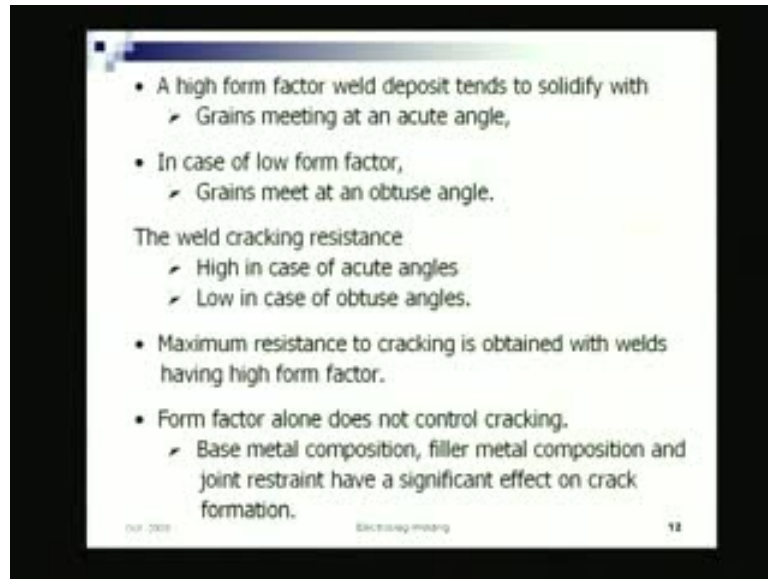

But all those different combinations may give a different form factor, not all of them but many of them will give different form factor, means we will fuse this width of the molten zone. Essentially, form factor is nothing but the dimension of the molten zone, which is called weld pool. This is how, this grain stuff is the molten zone; the metal is in molten condition. So, the shape of the molten zone, the size, the width, and the depth the ratio of that, so, that ratio has to be controlled in such a fashion that, such that, I have maximum resistance to cracking.

(Refer Slide Time: 36:48)

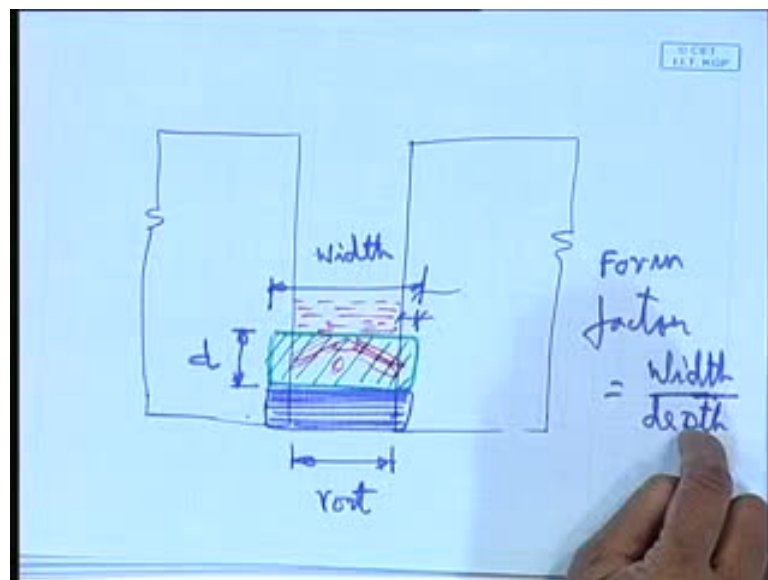

So, what I need? I need a high form factor because the weld cracking resistance is high in case of acute angles, and a high form factor gives an acute angle. What is high form factor? Higher width, lesser depth, that means I should be able to maintain a lesser depth of weld pool, that means it is preferable to have a wider root gap preferable to have a wider root gap, such that I can make this width to depth ratio higher.

(Refer Slide Time: 37:01)

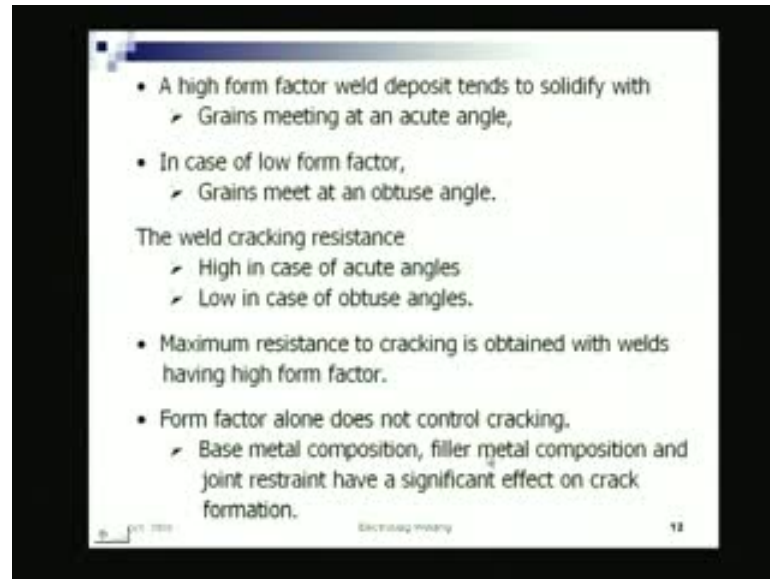

Well, so, that is one aspect also it does not mean that only form factor alone controls the cracking, definitely not. So base metal composition, filler metal composition, joint restrains, all those other aspects are there, but what it means is this is one of the important aspect, the form factor which needs to be controlled, such that I have a higher value of it, such that I achieve a higher resistance to cracking.

(Refer Slide Time: 37:36)

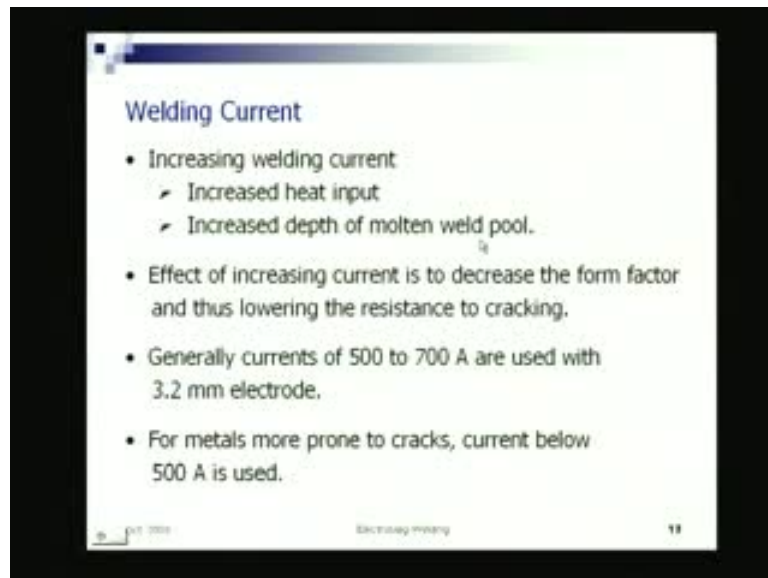

Well, now let us see the effects of other welding variables, welding current. As you know increasing welding current, it will increase the heat input. Increase depth of molten weld pool, you see this, second aspect, increased depth of molten weld pool, this depth is increasing. So that indirectly means that you generally do not use higher amperage for welding. When we talk about, will be welding thick plates then immediately one would tend to think that I will use high amperage, because I need to melt more metal, I need more heat. So, it is not directly that, I need more heat but at lower amperage, that means I reduce the welding speed.

(Refer Slide Time: 38:37)

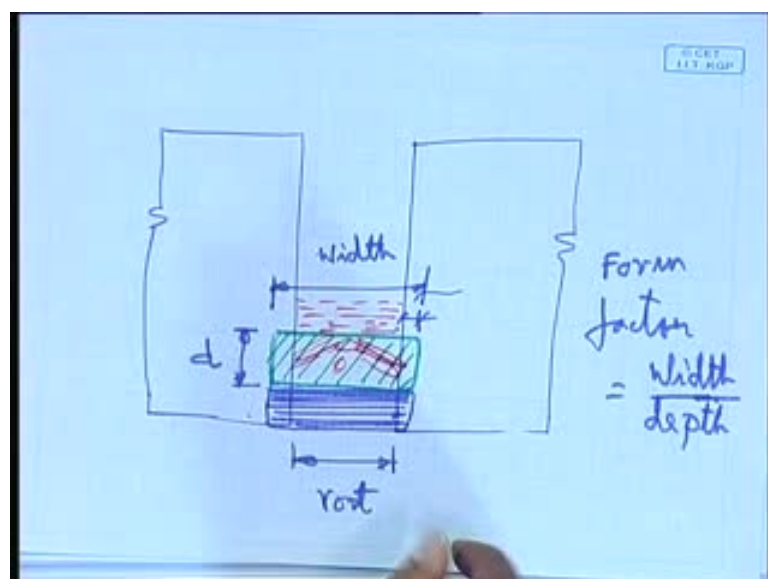

(Refer Slide Time: 38:48)

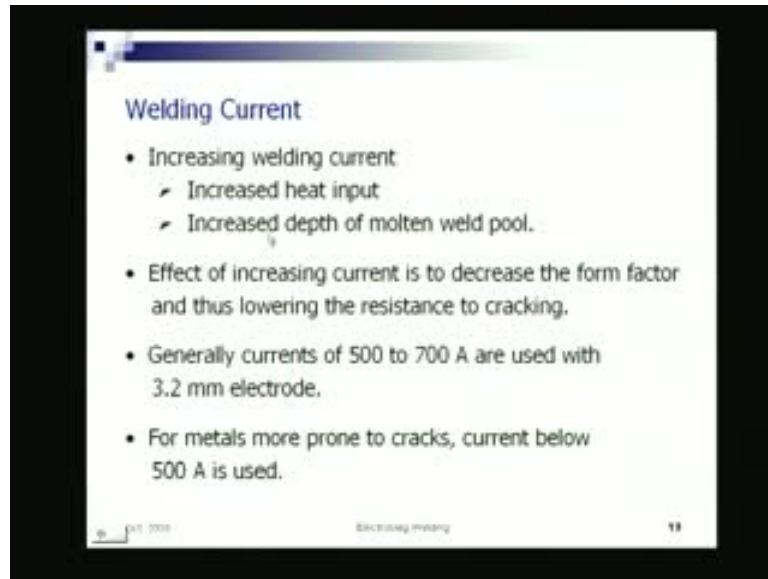

So, that is what, because if I increase the welding current, it will increase the depth of the molten weld pool. This depth increasing means form factor reducing, but we do not want to reduce the form factor, it has to be kept as high as possible. So, the welding current is kept lower. That is how we see the effect of increasing current is to decrease the form factor and thus lowering the resistance to cracking.

So, thereby, generally currents of the range of 500 to 700 are used with 3.2 millimeter electrodes, that mean you do not really go for very high amperage. For metals, more prone to cracks, current below 500 ampere is used. Metals more prone to crack mean what? Metals having higher carbon equivalent, where the carbon percentage is high and other alloying percentages are also high, which gives you the carbon equivalent. If the carbon equivalent is high, **is a tendency** there is a possibility of hard brittle phase forming in the metal after solidification. So, there such metals are prone to cracking. So there you used current less than 500 ampere.

(Refer Slide Time: 39:46)

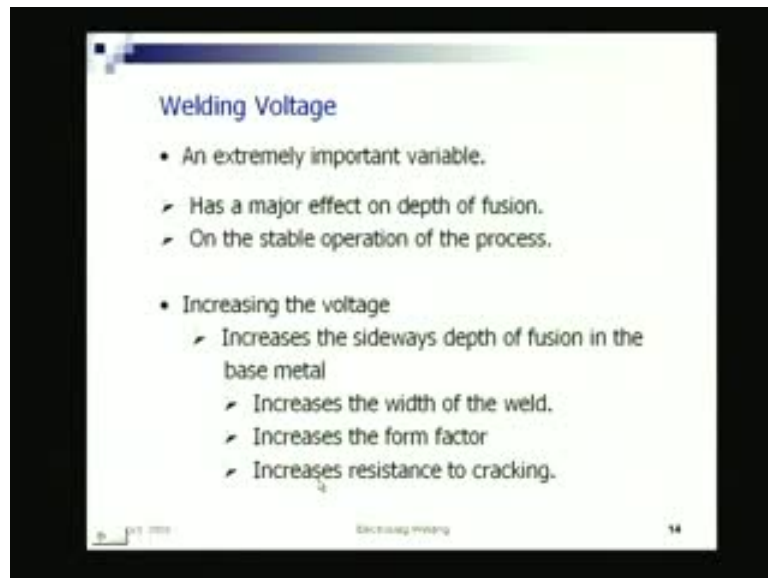

(Refer Slide Time: 40:14)

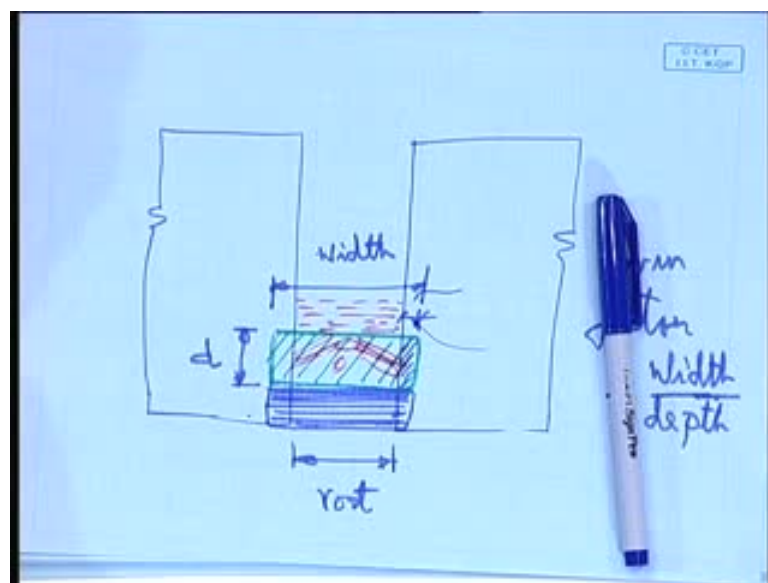

Welding voltage: it is an extremely important variable in this case, in case of electro slag welding, why? It has a major effect on depth of fusion. Again, on the depth of fusion, on the stable operation of the process, increasing the voltage, it increases the side wise depth of fusion in the base metal, this depth of fusion, this one, the side wise depth of fusion of the metal; increasing the voltage this increases, that means the dilution in the metal increases. In the weld pool, the more of parent metal you increase the welding voltage, it is not arc voltage, this is the welding voltage because there is no arc as such this voltage is that voltage drop across that molten slag, voltage drop across the molten slag.

(Refer Slide Time: 40:53)

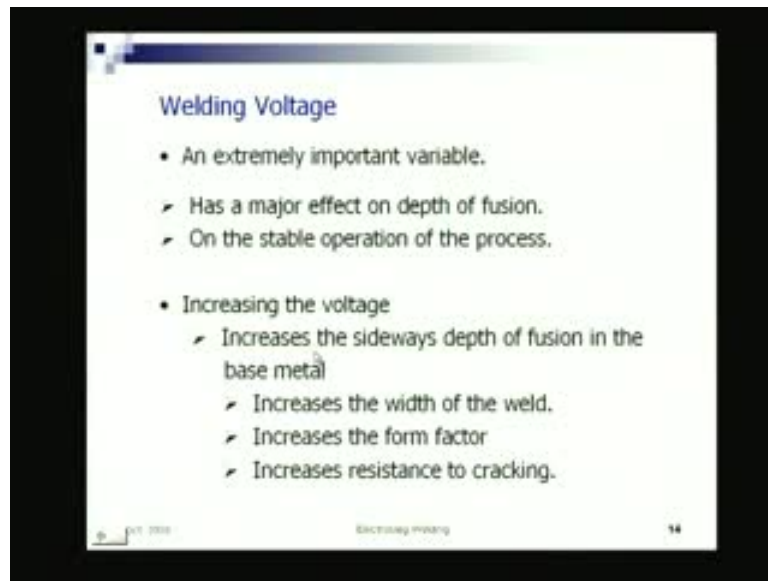

So, increasing that, it increases the side wise depth of fusion, the base metal that increases the width of the weld that increases form factor increases resistance to cracking. So, we can see, increasing current has a negative effect on resistance to cracking, but increasing voltage has a positive effect, why? Because, it increases the width, the sideways fusion increases, and therefore, the form factor increases.

(Refer Slide Time: 41:22)

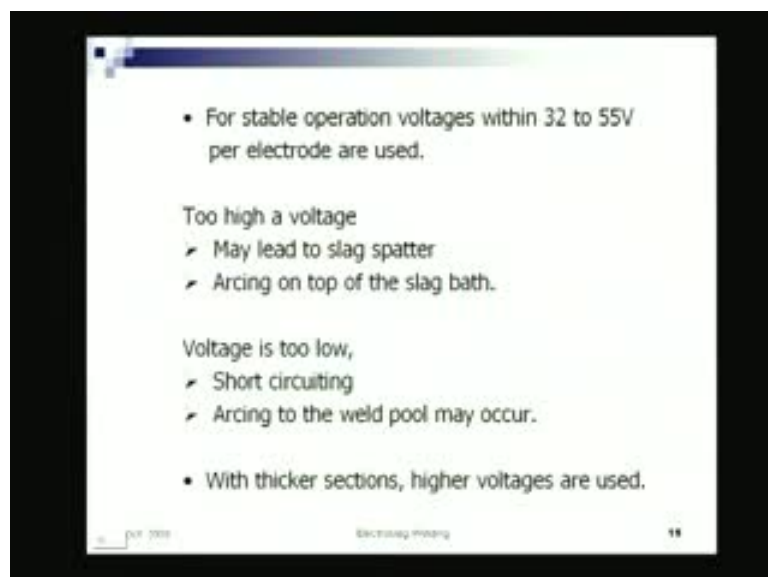

For stable operation, voltage is within 32 to 55 volt per electrode is used. You can see the voltage level. For any other welding, the your welding arc voltage vary within the range

of around say 20 volts to 30 volts, generally, 20 volts to 30 volts. Here you see, it starts from 32 and goes up to 55. We use a higher welding voltage because of this factor, that it increases the depth of fusion in the parent metal, thereby increases the form factor.

But, well, again that same logic that anything too much is not good, that way too high a voltage may lead to slag spatter arcing on top of the slag bath, that means it does not mean that you go on increasing the voltage, you will go on increasing this, and improve the form factor, no. Beyond a certain point, again it will have other bad effects like slag, spattering of slag may take place, arcing on the top arcs may form on the top of slag bath. So, too high voltage is not good. Again, if the voltage is too low, then short circuiting may take place. Voltage too low means what means essentially the depth of the slag bath is small, because high voltage means what? Essentially we are talking about the voltage drop.

(Refer Slide Time: 43:03)

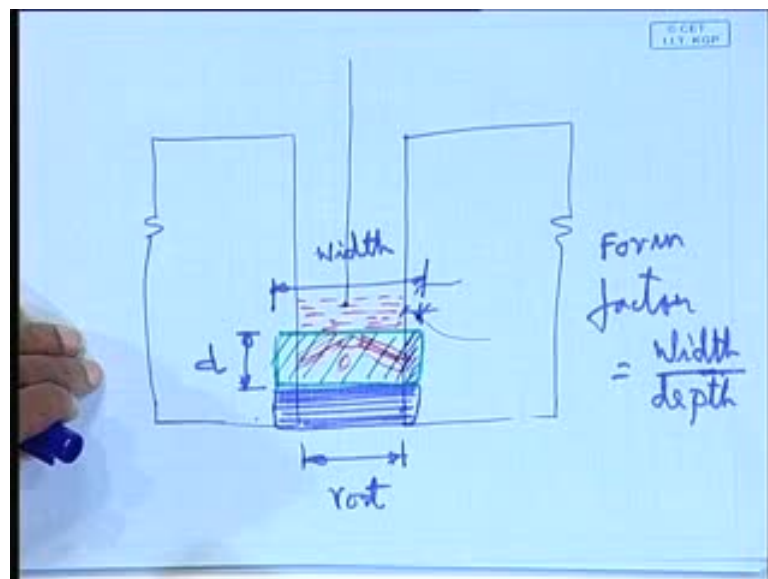

(Refer Slide Time: 43:10)

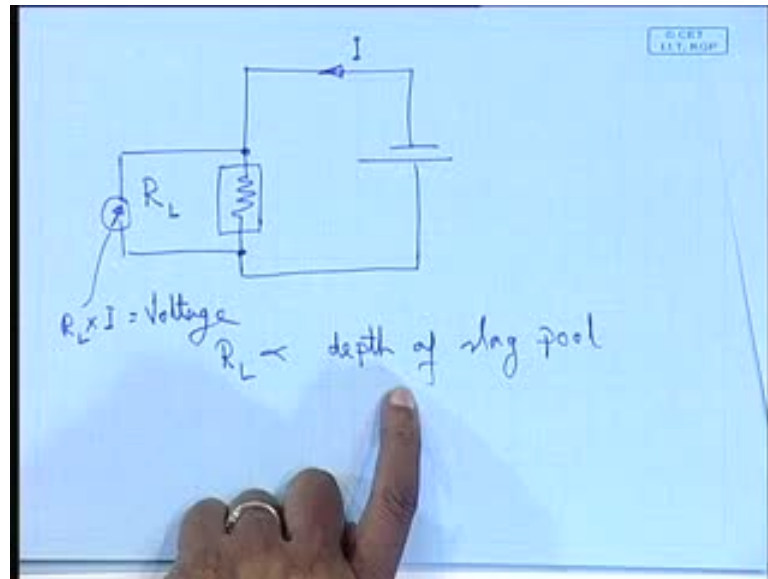

Because here, this is my electrode, it is dipped in the molten pool. So, what is that? This is basically that resistance is not it. This is the simple, very simple circuit. This is the load resistance; the load resistance is nothing but this load resistance is proportional to your depth of the slag bath. Depth of the slag, well, slag pool, more the depth, more resistance, is not it. More depth means more resistance as well as and here the current is flowing. So, the voltage drop across this is nothing but R_L in to the current and that is the welding voltage.

(Refer Slide Time: 44:41)

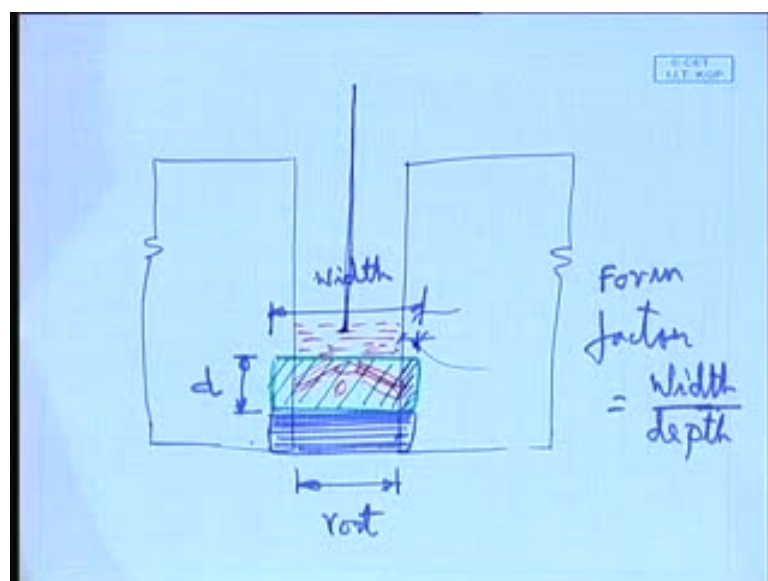

So, if R L is low, voltage is low; R L low means essentially depth of the slag pool is small, So, if I go on reducing the depth of slag pool, my voltage will go on reducing or reverse. I reduce the voltage that effectively means less slag bath. If the slag bath depth is less, there is a chance of short circuit, is not it, because the electrode is dipped in the slag bath. So, if this bath is small then there is a chance that it will touch the molten metal. So, it may cause short circuiting and arcing to the weld pool may occur.

Short circuit or arc may get initiated with the molten metal.

(Refer Slide Time: 45:09)

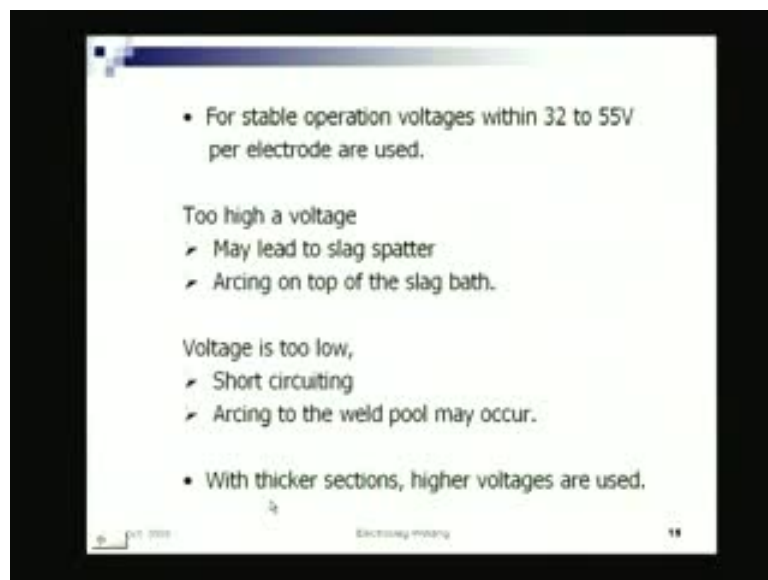

(Refer Slide Time: 45:22)

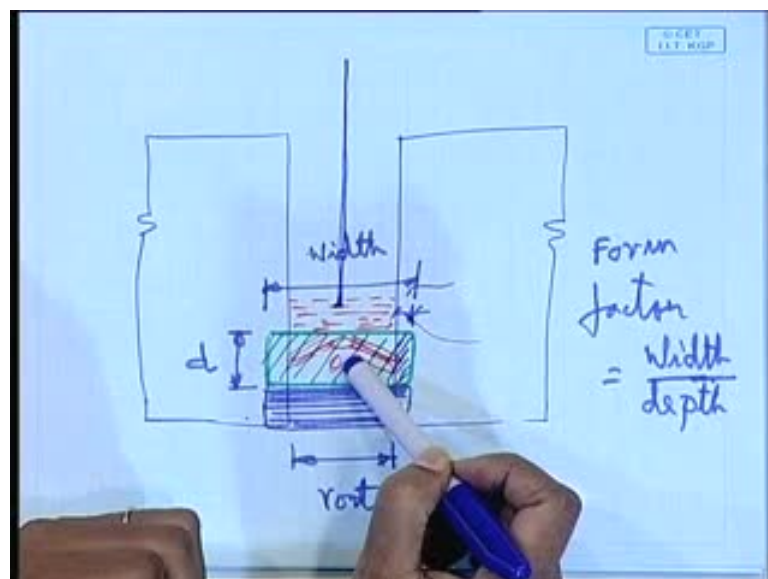

Well, with high voltage spattering occurring means what, it is overheating the molten slag bath, the molten slag bath, and the spattering essentially. Spattering means some kind of effect of boiling the molten slag takes place and gets spattered outside the bath. If spattering takes place, what happens? The problem is there is a chance of gas entrapping inside that means there will be turbulence in the slag bath. In the slag pool, there will be a turbulence created and once turbulence is created, what will happen? That means it can interrupt gases. If it interrupts gases, there is a chance that the gas goes in to the molten pool and remains trapped, so, porosity will come. It may lead to porosity or blow hole formations, so, these are the things.

(Refer Slide Time: 46:23)

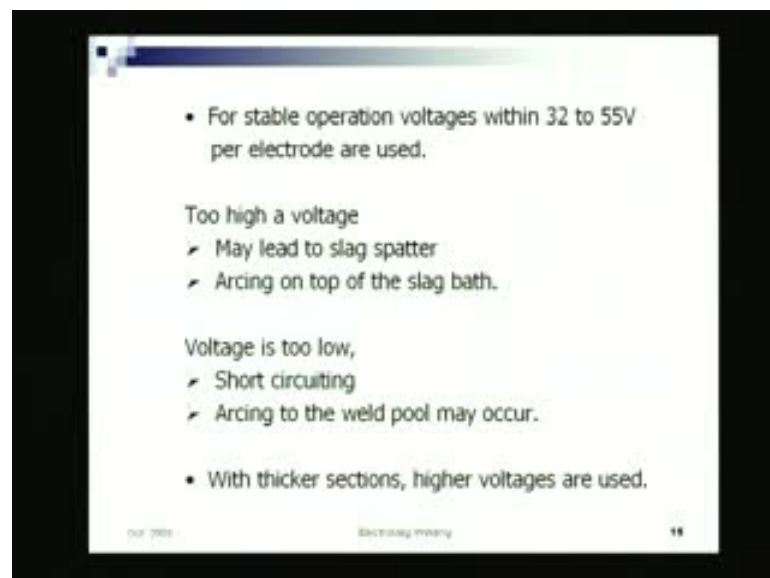

Well, with thicker sections higher voltages are used that means, higher means not this too high, it is not that like we have given a somewhat a range 32 to 55, it means when you weld the comparatively on the thinner side, you use lesser voltage; when you go for the higher thickness, you go for the higher voltage, but well, if you weld 400 meter thick plates possibly much higher voltages will be needed that we are not talking about here.

(Refer Slide Time: 46:57)

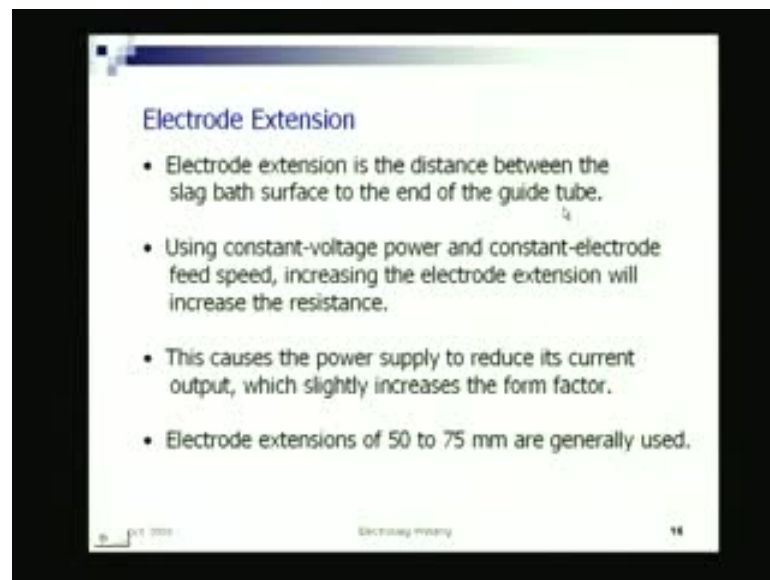

Electrode Extension

- Electrode extension is the distance between the slag bath surface to the end of the guide tube.
- Using constant-voltage power and constant-electrode feed speed, increasing the electrode extension will increase the resistance.
- This causes the power supply to reduce its current output, which slightly increases the form factor.
- Electrode extensions of 50 to 75 mm are generally used.

© 2008 Electroslag melting 14

(Refer Slide Time: 47:13)

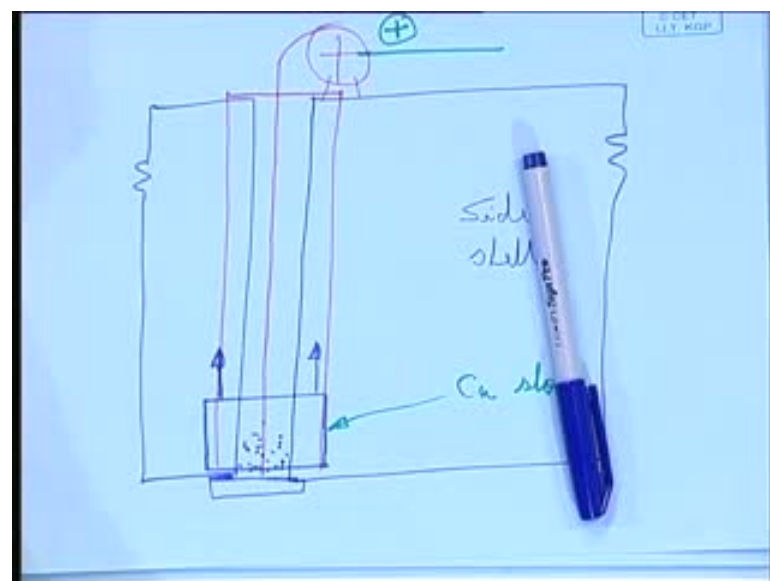

(Refer Slide Time: 47:28)

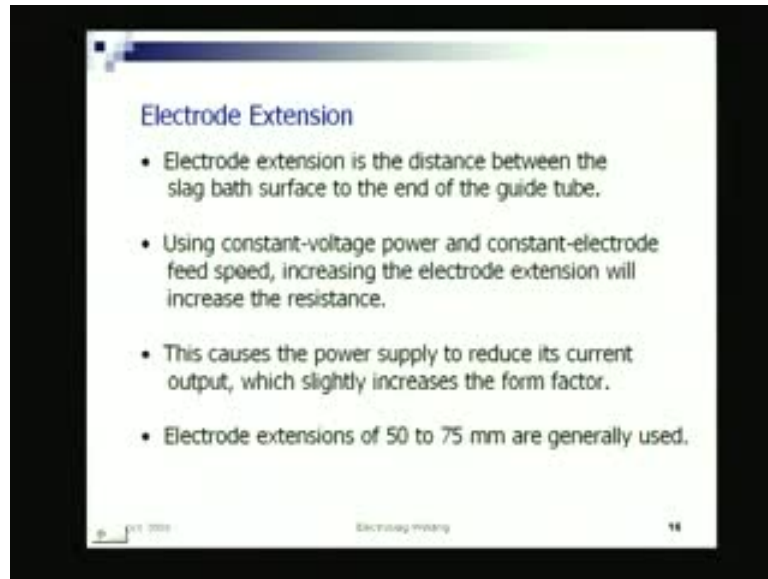

Well, electrode extension; here, again electrode extension is the distance between the slag bath surface and the end of the guide tube. This comes where you are using a guide tube and the power is fed to the guide tube. In this case, the electrode extends in the entire length, but if I have a guide tube, and well, power is fed to the guide tube at that region, then this particular thing is coming that with constant voltage power, and constant electrode feed speed, electrode extension will increase resistance extension up to 50 to 75 millimeter are generally used, that is for wire a guide tube is used.

(Refer Slide Time: 47:47)

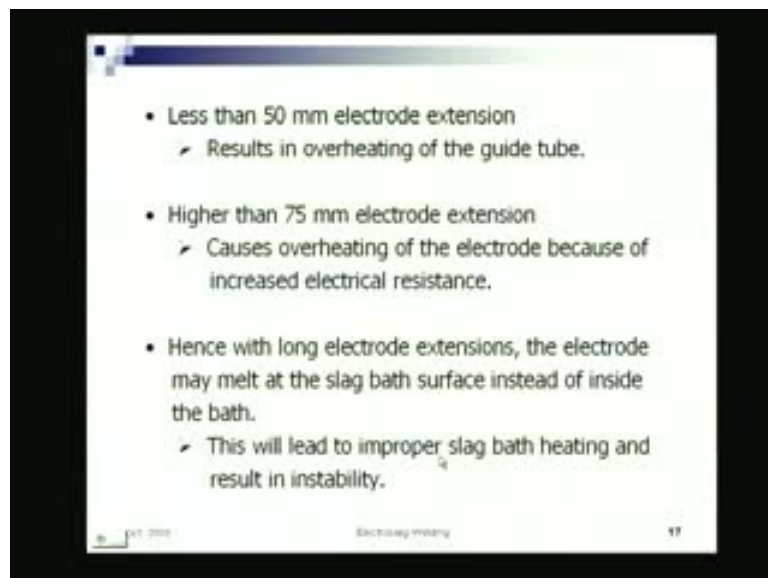

Less than 50 millimeter results in over heating of the guide tube; higher than 75 causes over heating of the electrode because of increase electric resistance, that same thing what we used in case of gas metal arc welding or even submerged arc welding is more the length of extension, more heat is generated there because of the resistance of that part squared the current.

(Refer Slide Time: 48:53)

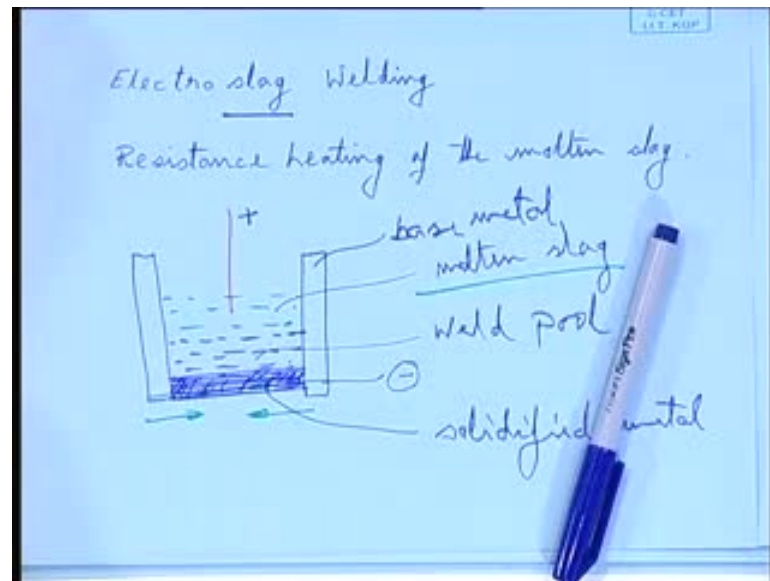

Hence with long electrode extension, the electrode may melt at the slag bath surface instead of inside the bath. So, here also there we saw in submerged arc we do not generally keep a very long extension because it becomes unstable, it becomes heated up. So, it may not come down vertically over the molten pool but it may get deflected. Here what happens, if it is too long, they may get heated up so much that it melts at the slag bath surface instead of inside the bath because it should melt inside the bath. The melting should take place inside not at the top of the surface, because if it is melting at the surface means what? It is getting exposed to the atmosphere. It will get oxidized. It should melt inside such that it is shielded cautiously.

(Refer Slide Time: 49:10)

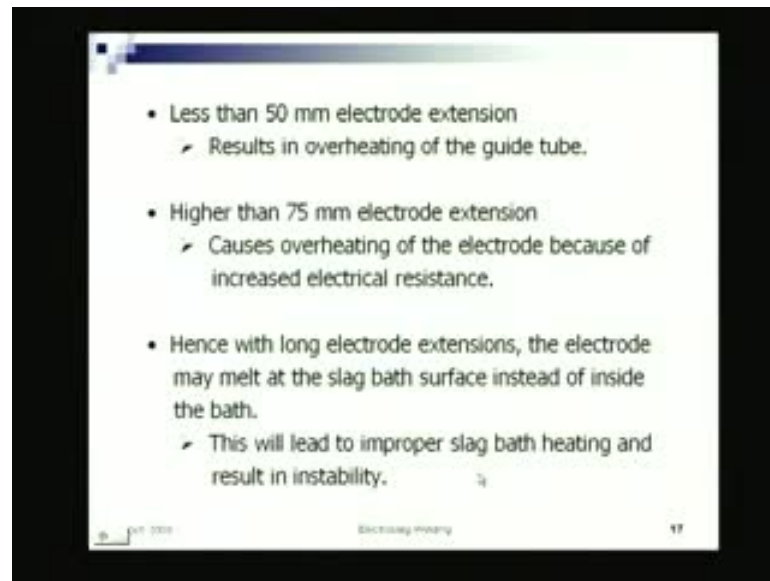

So, this will lead to improper slag bath heating and result, well, hence, long so lead to improper bath heating and result in stability.

(Refer Slide Time: 49:22)

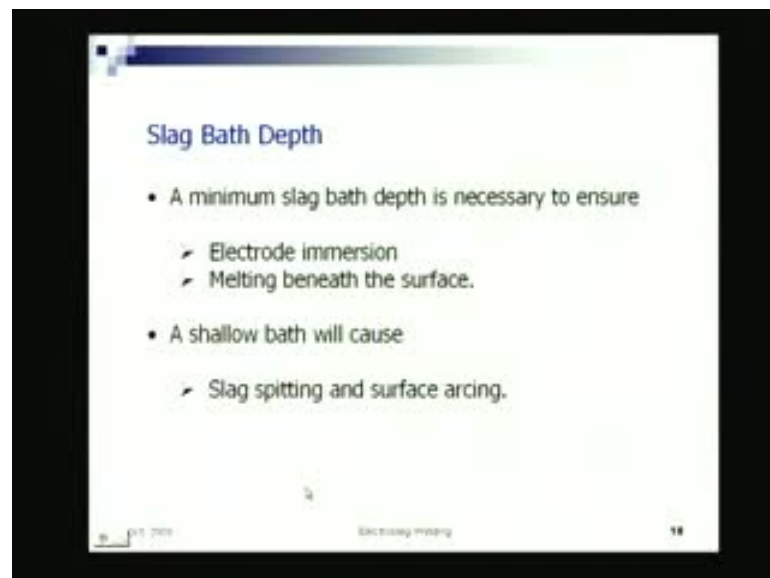

(Refer Slide Time: 49:28)

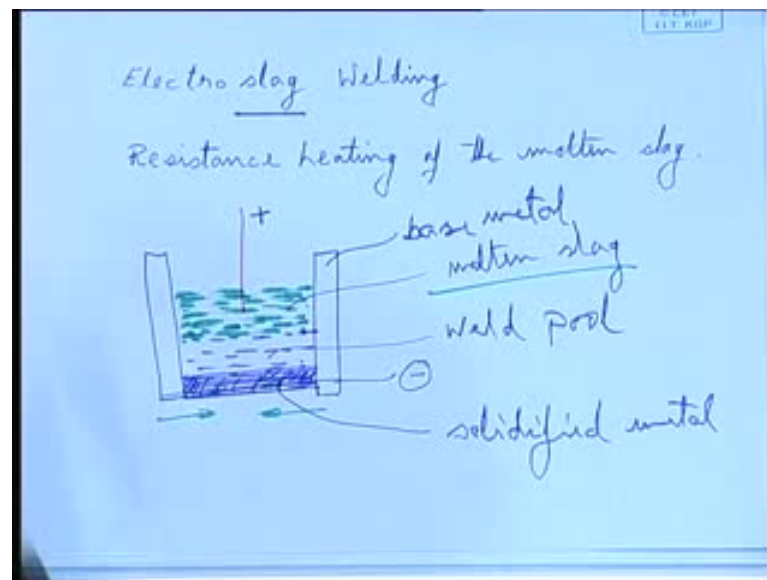

(Refer Slide Time: 49:43)

Slag Bath Depth

- A minimum slag bath depth is necessary to ensure
 - Electrode immersion
 - Melting beneath the surface.
- A shallow bath will cause
 - Slag spitting and surface arcing.

© JCT 2018 Electroslag welding 18

(Refer Slide Time: 49:50)

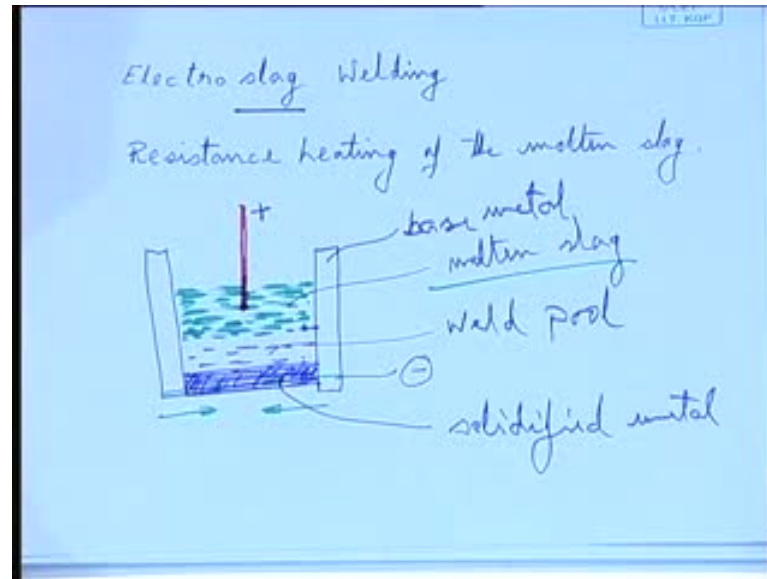

Slag bath depth: how deep this bath should be that means as we have schematically drawn here this is my, this green stuff is the slag bath that means the bath of that molten pool of slag, how deep it should be the minimum? Slag bath is necessary to ensure electrode immersion such that the electrode can come inside, sufficient immersion of the electrode takes place. Sufficiently, inside it should come. Melting beneath the surface that is important not at the top of the surface but below the surface, I mean inside the slag bath the electrode tip should melt. It is not that, it is melting here at the top. It should melt inside a shallow bath will cause slag splitting and surface arcing. Shallow bath means, well, it may start initiate the arc may be compressible.

(Refer Slide Time: 50:26)

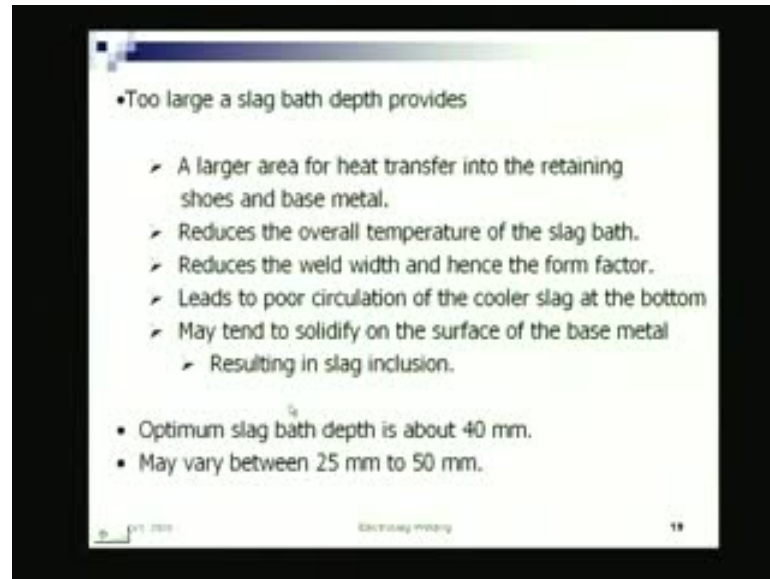

(Refer Slide Time: 50:49)

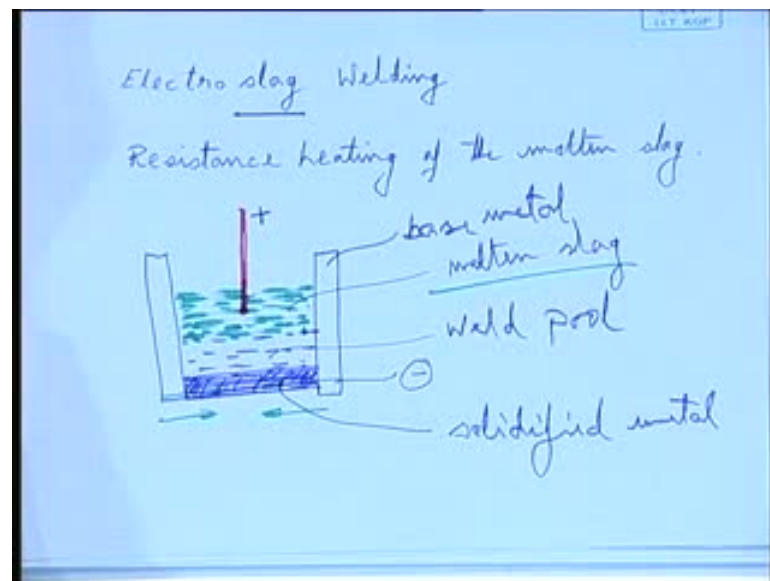

Too large a slag bath again the opposite, if it becomes too much of flux, I have put how that how big flux slag bath will come too much of flux has been put right. So, what will happen, a larger area for heat transfer in to the retaining shoes and base metal. Too much of this means, what? Too much of heat is generated. Too much of heat is getting conducted both thing the base metal as well as the shoe.

(Refer Slide Time: 50:56)

• Too large a slag bath depth provides

- A larger area for heat transfer into the retaining shoes and base metal.
- Reduces the overall temperature of the slag bath.
- Reduces the weld width and hence the form factor.
- Leads to poor circulation of the cooler slag at the bottom
- May tend to solidify on the surface of the base metal
 - Resulting in slag inclusion.

• Optimum slag bath depth is about 40 mm.

• May vary between 25 mm to 50 mm.

© 2010 Electrical Engineering 19

(Refer Slide Time: 51:20)

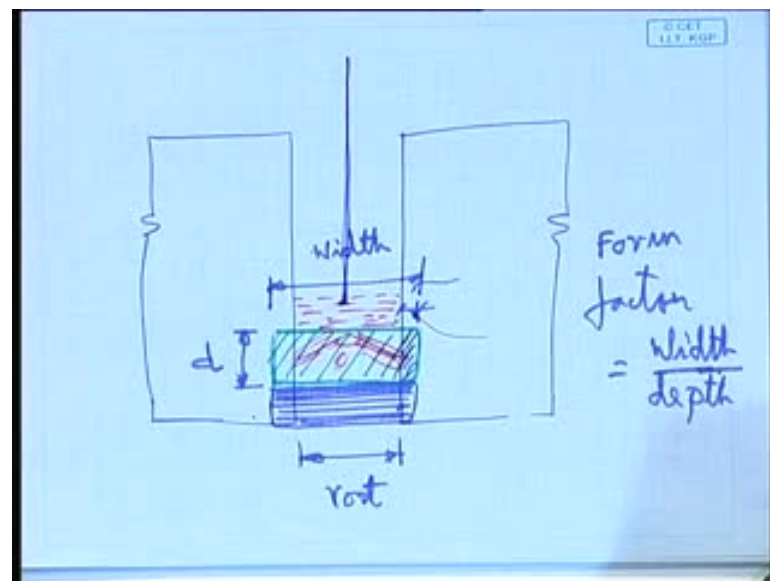

(Refer Slide Time: 51:30)

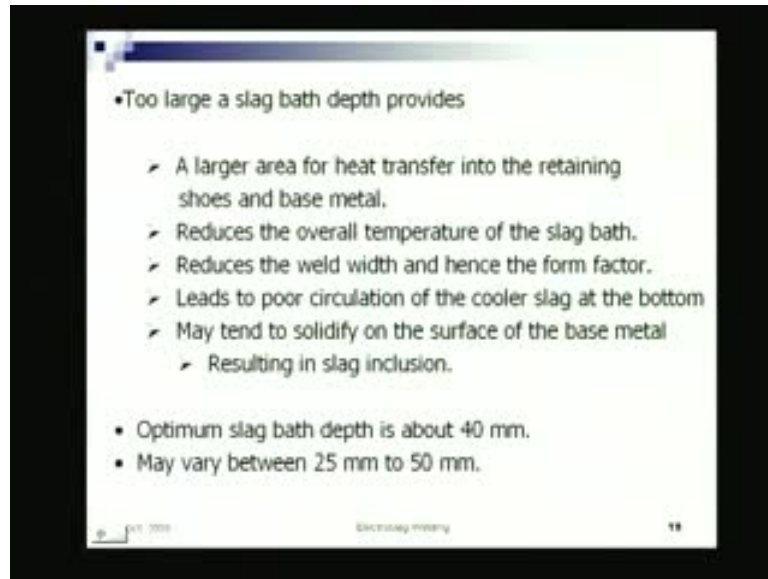

Reduces overall temperature of the slag bath because the heat content is there, the volume is more, overall temperature may become less, reduces weld width and hence the form factor because the overall temperature is reducing then the fusion in the parent metal reduces. Fusion in the parent metal reduces that means the width of the molten metal, the overall weld width reduces and there by the form factor. So, that is again is not desirable.

(Refer Slide Time: 51:45)

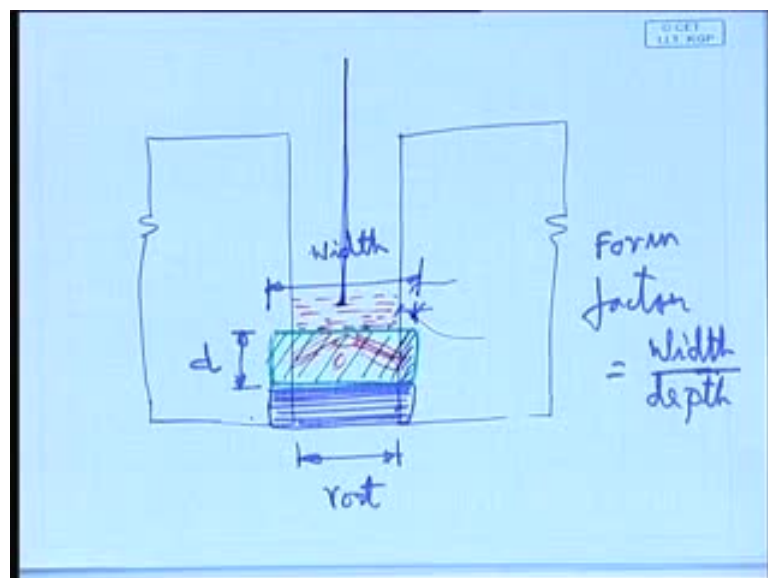

Leads to poor circulation of the cooler slag at the bottom, because you see, the slag at the bottom is somewhat cooler compared to the slag at the top. So, still some kind of circulation is needed. If the circulation is not there, the slag will get solidified below.

(Refer Slide Time: 52:00)

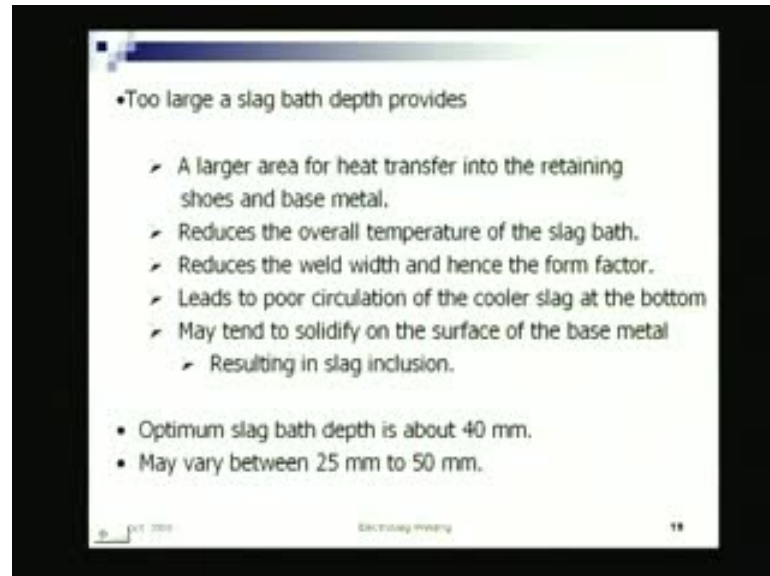

• Too large a slag bath depth provides

- A larger area for heat transfer into the retaining shoes and base metal.
- Reduces the overall temperature of the slag bath.
- Reduces the weld width and hence the form factor.
- Leads to poor circulation of the cooler slag at the bottom
- May tend to solidify on the surface of the base metal
 - Resulting in slag inclusion.

• Optimum slag bath depth is about 40 mm.

• May vary between 25 mm to 50 mm.

© IIT KGP

(Refer Slide Time: 52:10)

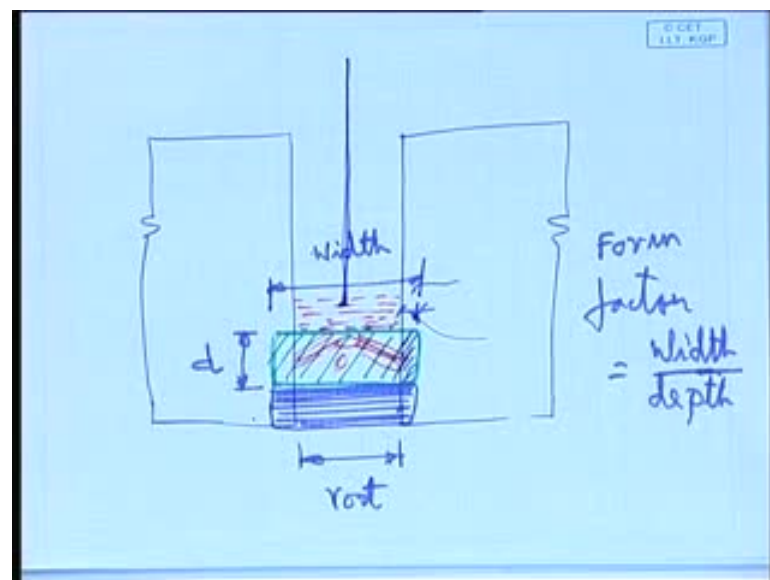

(Refer Slide Time: 52:17)

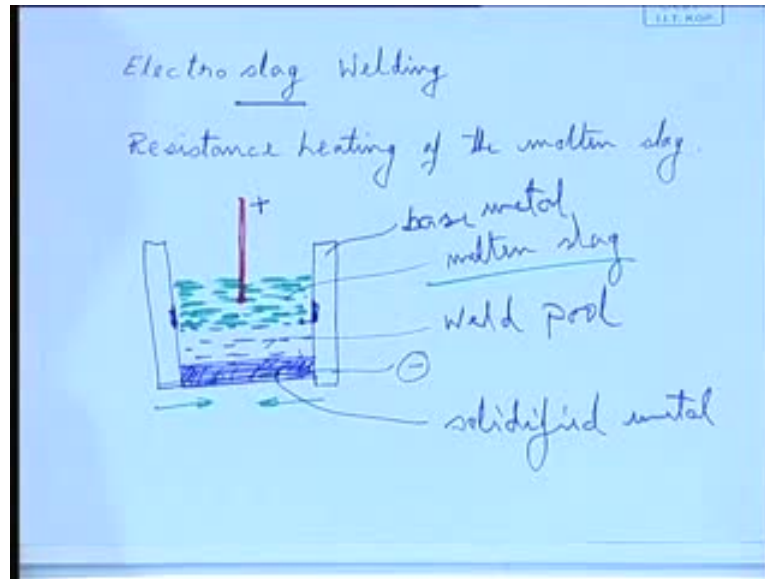

(Refer Slide Time: 52:42)

- Too large a slag bath depth provides
 - A larger area for heat transfer into the retaining shoes and base metal.
 - Reduces the overall temperature of the slag bath.
 - Reduces the weld width and hence the form factor.
 - Leads to poor circulation of the cooler slag at the bottom
 - May tend to solidify on the surface of the base metal
 - Resulting in slag inclusion.
- Optimum slag bath depth is about 40 mm.
- May vary between 25 mm to 50 mm.

Electroslag welding 19

(Refer Slide Time: 52:54)

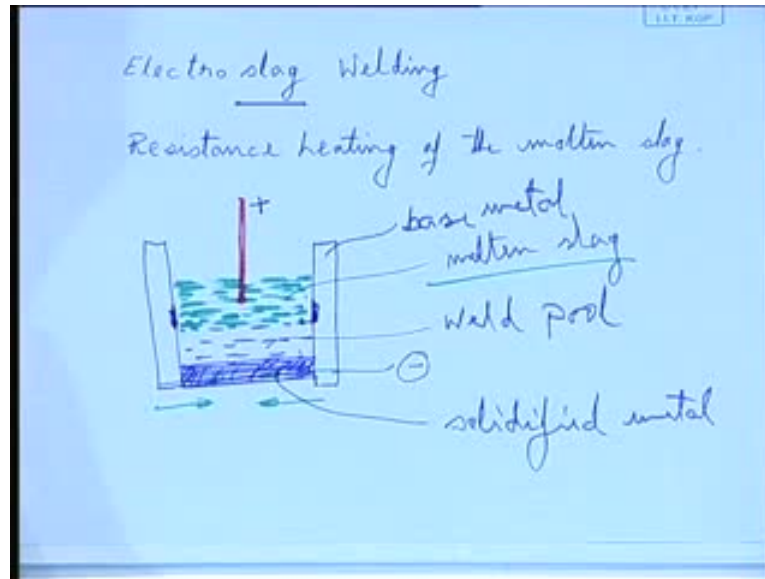

It may tend to solidify on the surface of the base metal resulting in slag inclusion on the side. On the base metal, the slag may get solidified. If the volume is too large, if the volume of this slag bath is too large, the slag may get solidified on the base metal side. If it gets solidified, then slag inclusion will take place means over that the molten metal will come, this will remain there, the slag particles will remain. So, that will lead to a called slag inclusion. So, optimum bath depth is about 40 millimeter, it may vary between 25 to 50. So, around 25 to 50 millimeter is the one should try to maintain the depth of the slag pool.

(Refer Slide Time: 52:56)

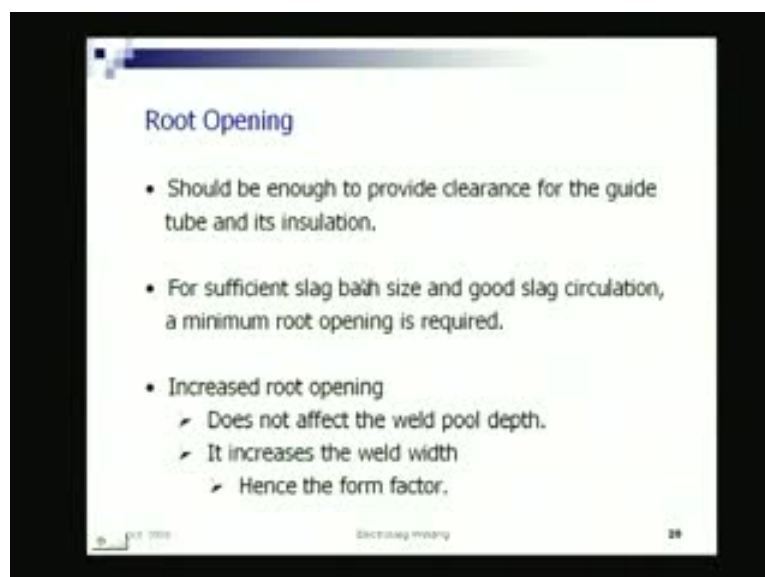

Root opening: the gap between the two plates being welded that is the root opening. That should be enough to provide clearance for the guide tube and the insulation. Obviously, for sufficient slag bath size and good slag circulation minimum root opening is required. On one side should be enough to have the guide, such that I can put the guide through which the electrode will come. Again I should be looking for to keep it as minimum, such that sufficient slag bath size and good slag circulation takes place.

(Refer Slide Time: 53:44)

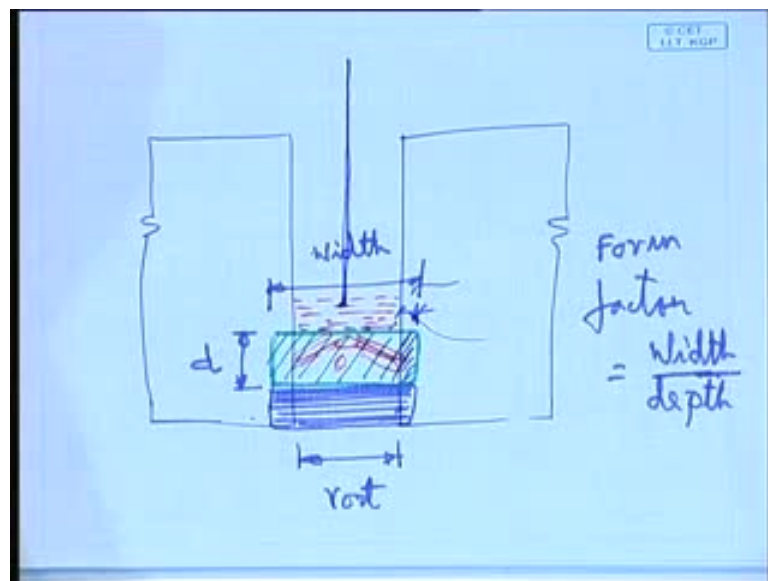

(Refer Slide Time: 53:57)

Root Opening

- Should be enough to provide clearance for the guide tube and its insulation.
- For sufficient slag bath size and good slag circulation, a minimum root opening is required.
- Increased root opening
 - Does not affect the weld pool depth.
 - It increases the weld width
 - Hence the form factor.

© 2010 Electrical Engineering 28

(Refer Slide Time: 54:10)

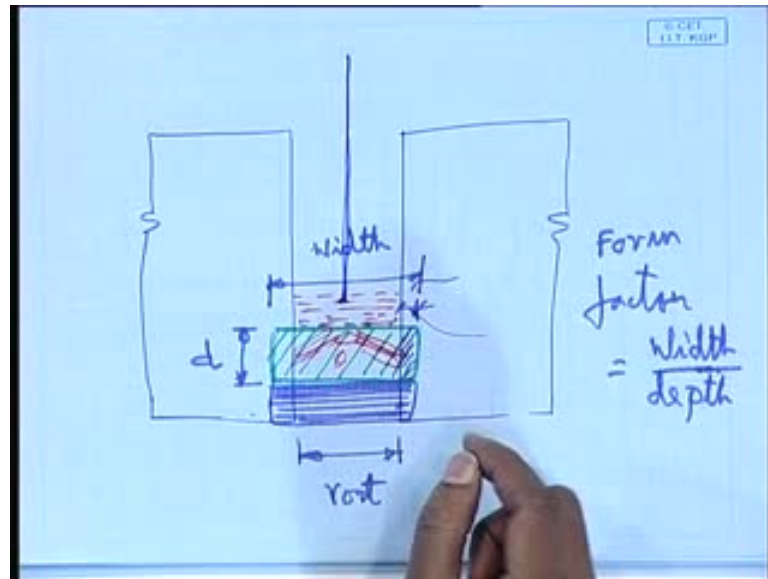

(Refer Slide Time: 54:26)

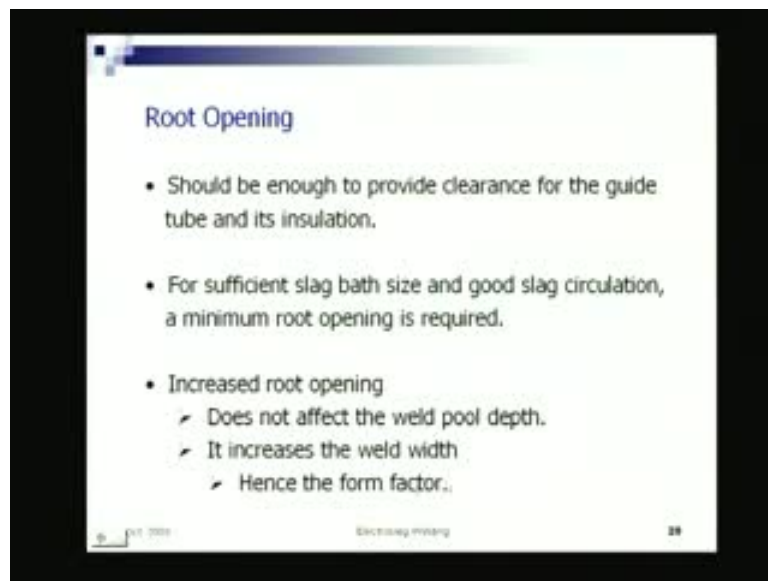

So, increased root opening does not affect the weld pool depth. What we said that if I have to increase the weld pool width, if I increase the root opening not necessarily your total width increases, because this is increasing, this also increasing, the depth. So, the form factor does not help. It increases the weld width, and hence, the, **sorry**, increased root opening does not affect the weld pool with weld pool depth, does not affect the weld pool depth, if I increase the opening. So, thereby, it helps in increasing the form factor because with root opening does not have any effect on the depth of the molten pool.

(Refer Slide Time: 54:29)

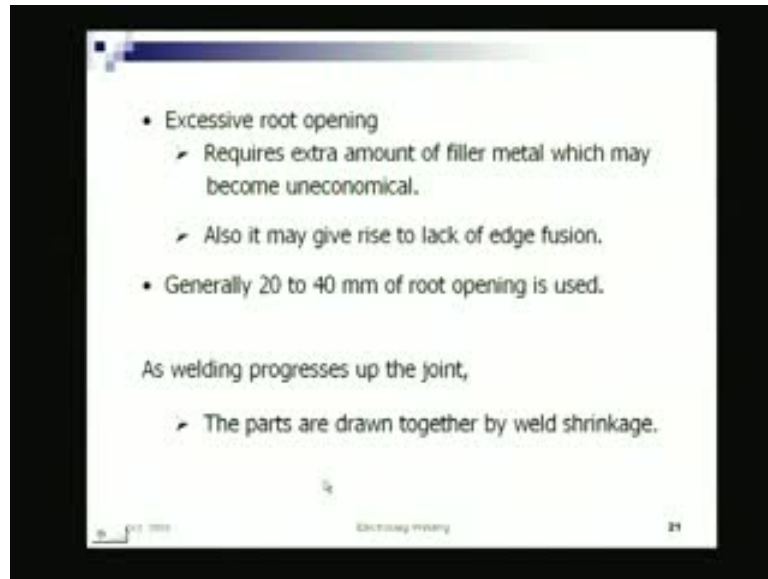

Now, if I have an excessive opening, like here I have drawn, exaggerated is drawn too much opening, it requires extra amount of filler metal which may become uneconomical. These are other aspects. Also, it may give raise to lack of edge fusion. So, as such what we can see, if we have a really big opening it - otherwise does not matter, only thing the process is not very viable; too much of filler metal you will have to give; too much of power has to be consumed to melt that.

Generally, a 20 to 40 millimeter root opening is kept. See, 20 to 40 millimeter, whereas, in any conventional butt welding using submerged arc or any other process, you talk about a root opening of 0 to 5 millimeter, maximum; 0 to 5 that means no opening at best you go up to 5 millimeter. Here, it is 20 to 40 several times higher.

(Refer Slide Time: 55:47)

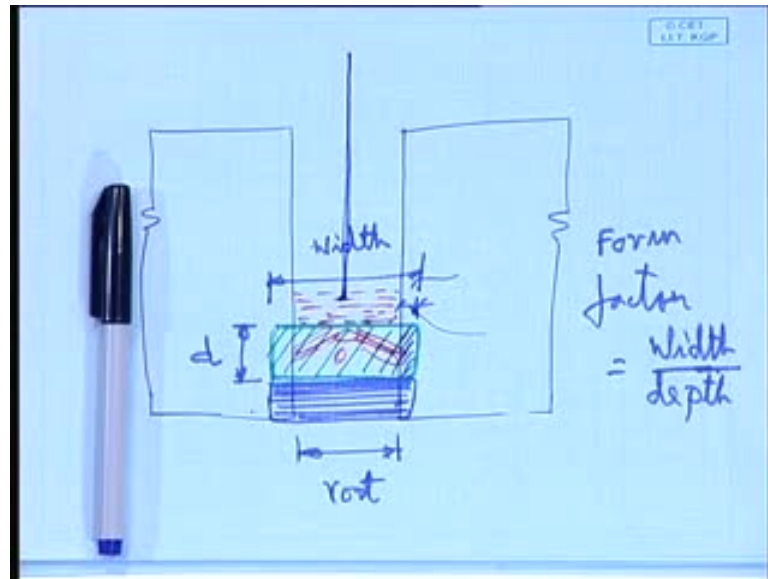

(Refer Slide Time: 55:55)

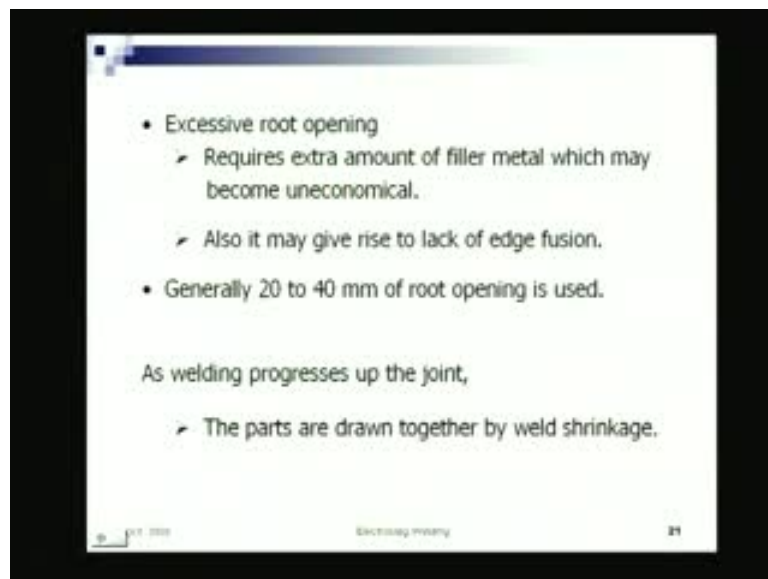

Here, what you are referring as welding progresses up the joint, the parts are drawn together by weld shrinkage. That is there, that possibility is there, as the weld progresses, it is drawn together, that, it tends to close, but because of the other rigidity, that does not create a problem, but if we just two individual plates without any restraint in it, if I try to weld, it will gradually close, then you would not be able to weld it.

(Refer Slide Time: 56:09)

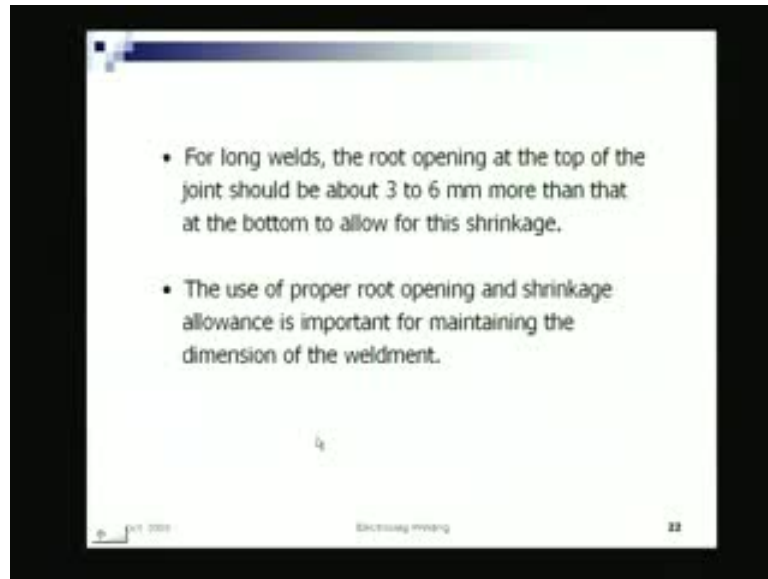

For long welds, the root opening at the top of the joint should be about 3 to 6 millimeter more than the bottom to allow for this shrinkage, for very long weld. So, when you make the alignment, you try to keep it like this, opening, such that it will close up, and **the** you will provide with the necessary root opening about 3 to 6 millimeter more, that means this is the kind of allowance, or in other words, suitable allowance to be evaluated and provided for in the root opening, because as you weld up words, there will be a tendency of it closing. The weld speed is slow, so, the thermal forces will act in such a fashion that a closing movement will work. So, the plates will tend to close. To counter act that initial setting will be like this, such that I keep additional opening, such that after shrinkage, it closes and gives me the required opening.

Sir is it necessary that the (())

(Refer Slide Time: 47:17)

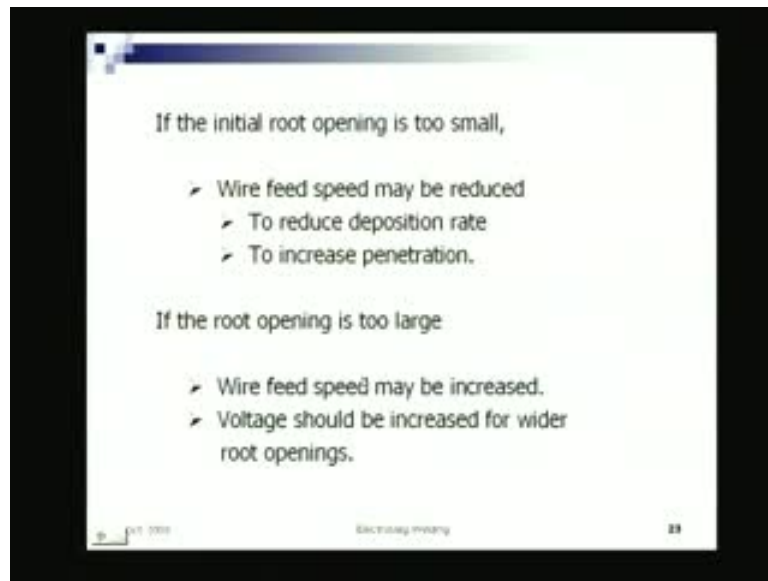

No, the whole process is such that we cannot go for a very high speed welding. Had it been a high speed welding, the case would have been different, it would have opened up, **it would have a opened up**, but here is a the very process is such that we cannot have a very high speed welding. So, here, necessarily the shrinkage is in this direction that means it closes. So, accordingly you take proper precaution.

(Refer Slide Time: 57:55)

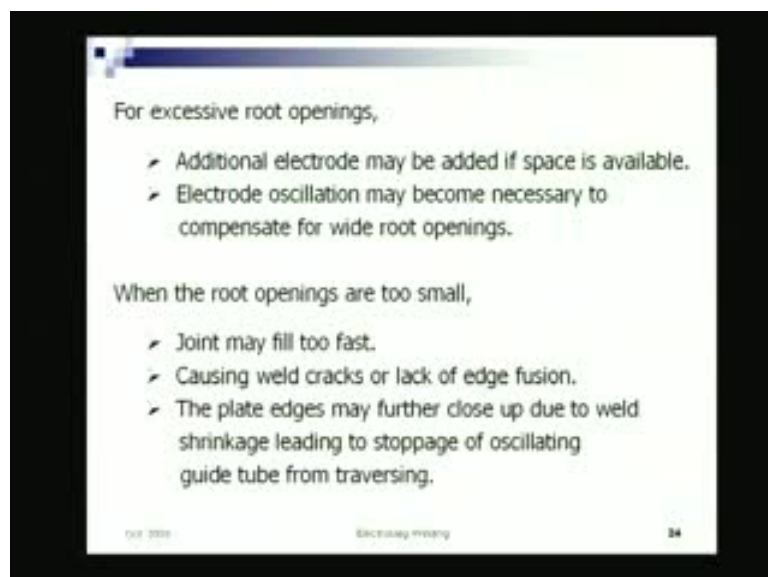

(Refer Slide Time: 58:10)

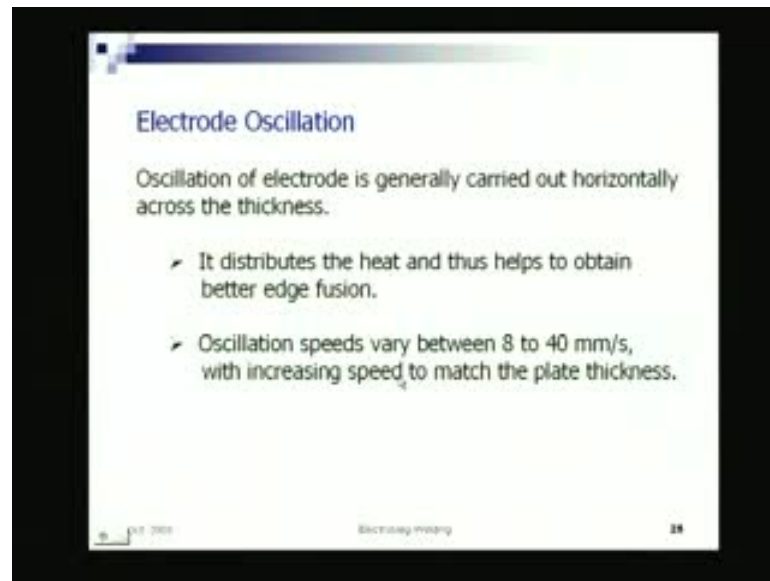

Well, when the root openings that, there are some more things are there. The root openings are too small, then it may cause weld cracks for lack of edge fusion, anyway, we will see that. There is an electrode oscillation of electrode is generally carried out horizontally across the thickness. Electrodes are oscillated at times, such that to distribute the metal more evenly such mechanisms are also there.

Anyway, in the next class, we will see little more of this, and then, we will go over to electrogas welding.