

**Metrology**  
**Prof. Dr Kanakuppi Sadashivappa**  
**Bapuji Institute of Engineering and Technology Davangere**

**Lecture – 29**  
**Radius Measurement, Contact Angle Measurement**

I welcome you all for module 8 lecture 3. In this lecture, we will be discussing about angle measurement and radius measurement.

**(Refer Slide Time: 00:34)**

**Topics covered**

**Angle measurement**

- Tilt measurement by autocollimator
- Contact angle measurement
- Angle gauges
- Spirit level
- Dovetail measurement

The topics covered in this lecture 3 are like this angle measurement under this will be we will be studying about tilt measurement by autocollimator and then contact angle measurement, angle gauges, spirit level and dovetail measurement.

**(Refer Slide Time: 00:59)**

## Radius measurement

1. Radius gauge (Fillet gauge)
2. Spherometer
3. Cylindrometer
4. Adjustable Outside/ inside radius gauges
5. Cutting tool radius measurement (optical system)
6. Digital radius gauge
7. Profile projector

Then we will move to the radius measurement and the radius measurement we will be studying about radius gauges, spherometer, cylindrometers, adjustable outside/inside radius gauges, cutting tool radius measurement by optical system, digital radius gauge and then profile projector.

**(Refer Slide Time: 01:25)**

## Tilt measurement using autocollimator



Now let us start the discussion on angle measurement or tilt measurement by using autocollimator you can see in this photograph. We have autocollimator setup we can adjust the height of this tube depending upon the work piece height and there is a stabilized voltage supply to light the light source and then there the various optical lenses are provided and then there is a viewing the eyepiece is there through which we have to the readings.

Now let us see how we can measure use this autocollimator for tilt measurement so we have surface plate on which we have kept a mirror reflecting mirror I can see here let us assume that they have kept this mirror on a surface work piece surface like this. A light ray will fall on the mirror and because of this tilt it will gets reflected in this path so this is the reflected light. This reflected light will fall on the glass scale provided inside the autocollimator so which we can read through the eyepiece.

**(Refer Slide Time: 03:36)**

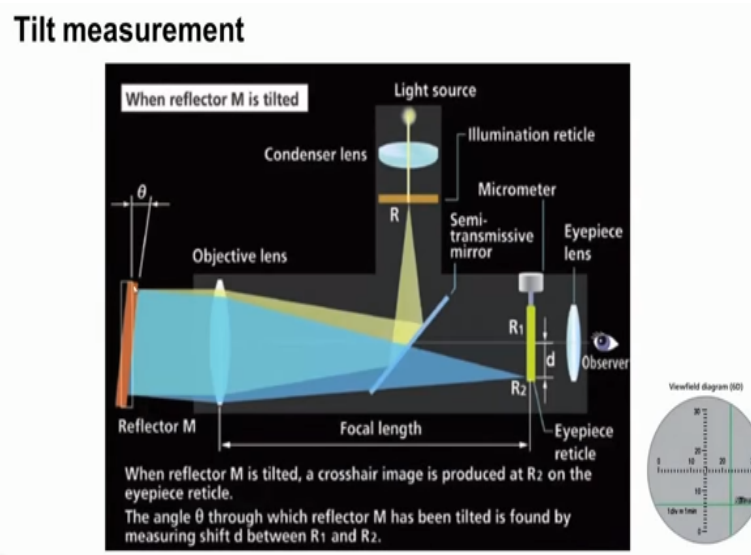

Now the constructional details are shown here this is the reflector M. Now you can see there is a small tilt of theta which we wish to measure I can see the objective lens and then eyepiece lens and there is a light source of light will fall on the mirror and then it will fall on the reflecting surface if there is a tilt the light gets reflected and then it will fall at point R2, so this distance d R1 and R2 we can measure using the eyepiece.

Now inside the view diagram, I can see here so the cross lines you can see this the reference point and you can measure what is the tilt angle, so the least count is 1 division = 1 minutes so by how many minute the surface has tilted that we can read.

**(Refer Slide Time: 04:58)**

## Contact angle

The contact angle is the angle, conventionally measured through the liquid, where a liquid/vapor interface meets a solid surface. It quantifies the wettability of a solid surface by a liquid via the Young equation.

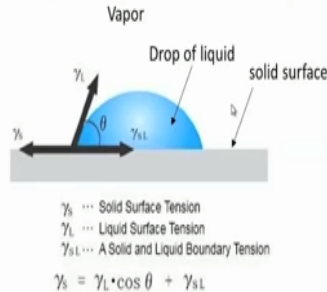

The angle  $\theta$  formed by the solid surface and the tangent of the droplet is called contact angle.

Now let us learn about the contact angle and measurement of contact angle this is the angle conventionally measured through the liquid where a liquid vapor interface makes a solid surface you can see here we have a drop of liquid and will be a vapor interval this is the vapor and the drop of liquid and this is a solid surface this contact angle quantifies the wettability of a solid surface by a liquid via the Younger equation.

At Young equation is written here we have the solid the surface tension liquid the surface tension solid and liquid boundary tension all these the factors are considered in this younger equation I can see this angle theta angle theta form by the solid surface and tangent of the droplet tangent of the droplet is called the contact angle.

**(Refer Slide Time: 06:12)**

The contact angle is used as an indicator of wettability, and has been adopted widely in industrial fields as an evaluation method of surface.

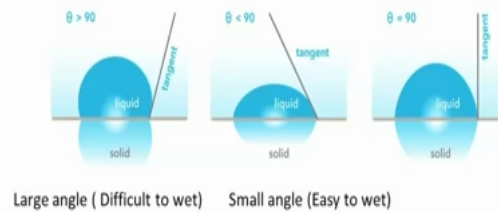

The low contact angle values indicate that the liquid spreads on the surface while high contact angle values show poor spreading. If the contact angle is less than  $90^\circ$ , the liquid wets the surface, zero contact angle representing complete wetting. If contact angle is greater than  $90^\circ$ , the surface is said to be non-wetting with that liquid.

Now this contact angle is used as an indicator of wettability and has been adopted widely in industrial field as an evaluation method of surface. By measuring this contact angle we can say what is the wettability between a liquid and a solid surface you can see here in this case this is a tangent theta angle theta is  $> 90$  degree. This is the angle theta which is  $> 90$  degree, if there is large angle then it is the difficult it means wettability is very poor.

If the angle is  $< 90$  degree it indicates that wettability is very easy. Now the low contact angle values indicate that the liquid spreads on the surface while high contact angle values show poor spreading, if the contact angle is  $< 90$  degrees the liquid wets the surface zero contact angle represents complete wetting if the angle is  $> 90$  degree the surface is said to be non-wetting with that liquid.

**(Refer Slide Time: 07:33)**

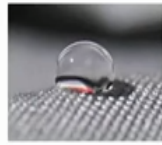

Cloth, treated with hydrophobic agent, shows a high contact angle.



A water drop on a lotus leaf surface shows a contact angle of approximately 147°

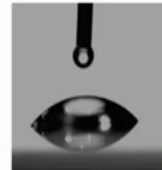

Image from a video contact angle device. Water drop on glass, with reflection below.

Now we can see here some image of varying we have a fabric cloth treated with hydrophobic agent so on this a drop of liquid placed I can see a very large contact angle which indicates the wettability is very poor and we have a lotus leaf on which a water drop is placed again you can see very large the contact angle of about 147 degrees.

So this image taken from a video contact angle device the water drop on glass plate with the reflection below, so the contact angle is less, so the wettability is good.

**(Refer Slide Time: 08:26)**

## Measurement of contact angle



A contact angle goniometer is used to measure the contact angle.

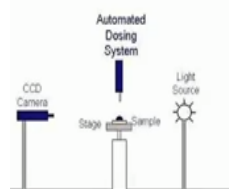
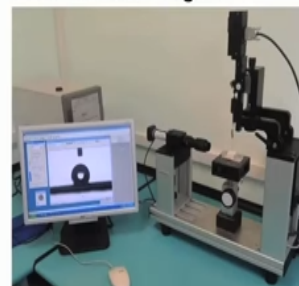

High resolution cameras and softwares are used to capture and analyze the contact angle.

Now how do we measure this contact angle, so a contact angle goniometer is used to measure the contact angle a few setups are shown here and a schematic diagram is shown here a high-

resolution CCD camera is used so there is a light source and there is a stage on which the dozing or a drop of liquid placed by using the using the dozing system and then the image is taken and then the software is used to get the contact angle.

So this contact angle is very important in the case of making of composite material wherein the liquid phase the for example polymer matrix is used with the fiber for difference maybe glass fibers or carbon fibers in that case we should know whether that wettability is good or not, so in such cases the contact angles are measured.

**(Refer Slide Time: 09:38)**

### Angle gauges

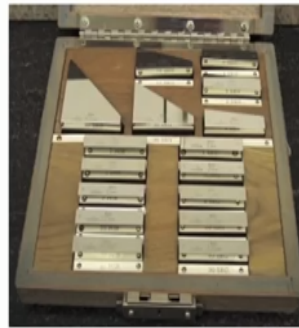

Set of 16 angle gage blocks. This set forms all angles between 0 to 99 deg in one second step – a total of 3,56,400 combinations.  
Laboratory master grade to an accuracy of  $\frac{1}{4}$  second  
Inspection grade –  $\frac{1}{2}$  second  
Tool room grade 1 sec accuracy

Now other important devices used or angled gauges these photographs were shows the set of 16 angle gauge blocks this set of all angles between 0 degree to 99 degree in one second step total of 3,56,400 combinations, so in the step of one second we can build the angle between this range 0 to 99 degrees.

Different grades of angle gauges are available laboratory master grade to an accuracy of  $\frac{1}{4}$  second is available an inspection grades in angle gauges are available with an accuracy of  $\frac{1}{2}$  and then tool room grade the angle gauges are available with one second access there so whenever we want to calibrate other device angle the measurement devices we use these laboratory master break for calibration of handle malinger dividers.

**(Refer Slide Time: 10:47)**

## 14 piece set

Degrees	Minutes	Seconds
1	1	3
3	3	6
9	9	18
27	27	30
41		

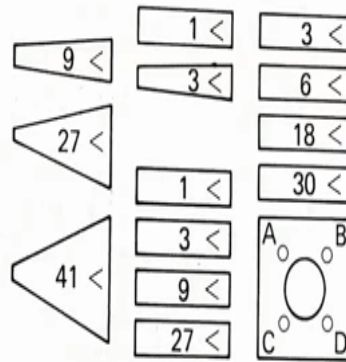

14 piece set

Now we can see here this table shows asset of 14 piece set we have a set of 5 pieces of 1 degree 3 degree, 9 degree, 27 degree and 41 degree and under the minutes category we have 1 minute gauge, 3 minute gauge, 9 minutes and 27 minute gauge and then under seconds we have 3 seconds gauge, 6 seconds gauge, 18 seconds gauge and 30 seconds gauge. In addition to these pieces we have another square block.

(Refer Slide Time: 11:28)

## Building angles

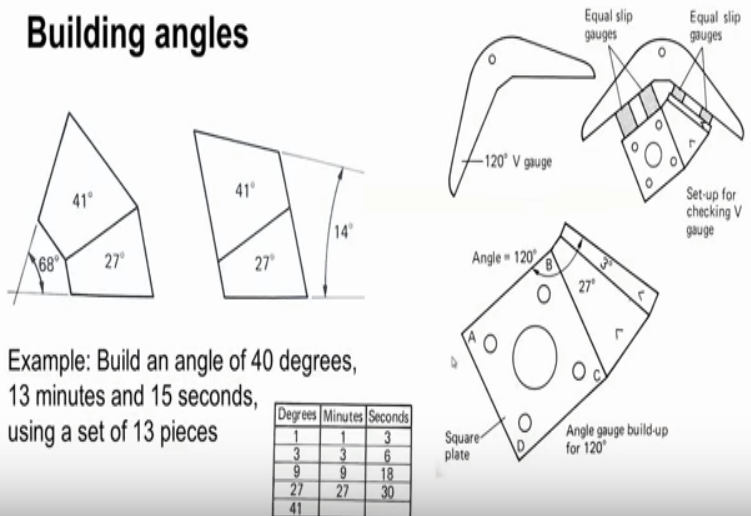

Now how do we build the angles using these angle gauges you can see here on the previous picture we saw we have this mark which indicates that this side is having smaller width and the other side it is having the larger width when we keep the angle gauges in this fashion where in



the mark is like this then the angle between this surface and this surface is totally 27 degree +41 degree.

So we get 68 degree when they are placed in the opposite sides like this then we have to subtract 27 degree from 41 degree so total angle between this surface and this surface is 14 degrees. So like this we can build the angles, so they have a work piece with an angle of 120 degree. So how do we check this work piece this V gauge, so I can see here we can use angle gauge if so we have used a 90 square plate and then a 27 degree gauge and then 3 degree gauge so totally it becomes 120 degree.

So this combination is used to check whether the angle on the work piece is proper is okay or not. Now let us take a simple numerical example build an angle of 40 degrees, 13 minutes and 15 seconds using a set of 13 pieces these are the angle gauges provided, so we have to build 40 degrees I can see here we have to take this 41 degree gauge block and then 1 degree gauge block and then we have to arrange like this.

So this is the 41 degree and then we have to subtract 1 degree from this so this is 1 degree so totally this angle becomes 40 degrees this is the combination A. Next we have to build an angle of 13 minute so to build 13 means we can select this 9 minute gauge block, 3 minute gauge block and 1 minute gauge block, so totally if they if you assemble them it becomes 13 minutes so this is the 9 minute.

And then we have to take 3 minutes 3 minute and then 1 minute, so totally this angle is 13 minutes then they have to build a 15 second for that we can collect 18 seconds Gauge and 3 seconds gauge and we have to assemble them. So this is 18 seconds and then we have to subtract 3 seconds from this 3 seconds so this angle becomes 15 seconds 15 second Celsius combination then finally we have to add all these combinations ABC.

So this is the combination A with 2 gauges, gauge blocks and then we have combination B with the 3 gauge block and we have another combination C with the 2 gauge block. So totally this angle is 40 degrees, 40 degrees, 13 minutes, 15 seconds so like this we can build the angle.

(Refer Slide Time: 17:28)

## Spirit level

A device consisting of a sealed glass tube partially filled with alcohol or other liquid, containing an air bubble whose position reveals whether a surface is perfectly leveled.

It is used to check the level of plane table by placing it on the board in two positions at right angles to each other. When the bubble remains in the centre at any point on the table, then table is considered to be properly leveled.

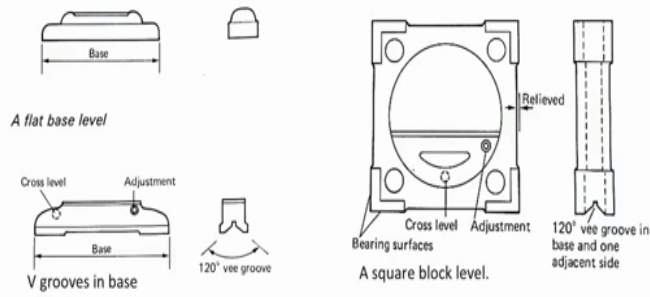

Now let us move to the another instrument spirit level which is mostly used for measurement of tilt of surfaces this is a device consisting of a sealed glass tube partially filled with alcohol or other liquid containing an air bubble whose position reveals whether a surface is perfectly leveled it is used to check the level of plane table by placing it on the board in 2 positions at right angles to each other and the bubble remains in the center at any point on the table then table is considered to be properly leveled.

So different configurations of spirit level are available this is a flat base level this is a glass tube which is partially filled with alcohol called a bubble here you can see the base is the flat and we have a V groove in base so you can see the side view we have a 120 degree V groove and the inside is a glass tube and this is sometimes where cross level also provided and this is a square block level again with the 120 degree with V on the base.

(Refer Slide Time: 18:58)

The glass tube has a slight **upward curve**, so that the bubble naturally rests in the centre, the highest point. At slight inclinations the bubble travels away from the marked center position.



Now the glass tube has a slight upward curve we can see in this photograph the slight upward curve so that the bubble naturally rests in the center when the base is properly is placed on a properly level in the surface the bubble will be at the center which is the highest point at slight inclination the bubble travel away from the marked center mark the center position to indicate what is a level.

**(Refer Slide Time: 19:33)**

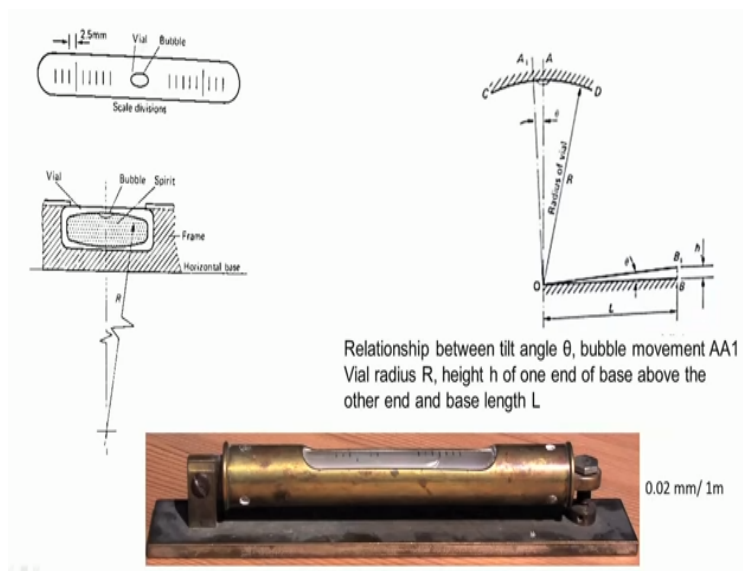

Now this is the glass tube with markings and at the center we have a bubble and this is a cross sectional view of the spirit level. This is the glass tube filled with spirit and there is a bubble which is this tube is placed in a frame and this is the base and this curvature is  $R$ . Now what is

the relationship between the tilt angle theta you can see here we have tilt angle theta a bubble moment.

So this is the when the when the surface is perfectly level bubble will be at the center A when there is a slight inclination tilt of theta and bubble moves from A to A1 and real radius R the radius of curvature or height H of 1 under the base above the other end. Now you can see here B and it has raised by H with respect to the origin O and base length L.

Now what is the relationship if the length is 1 L is 1 meter and if one N rises by an amount of say point 0.02 millimeter then bubble will move by one graduation if that means if bubble moves from A to A1 it indicates that the end B has rised by an amount of 0.02 millimeter. Now this photo shows a commercially available spirit level there is a this is a pivot and there is a provision for adjustment and it will be glass tube and we can also see the bubble and then the graduations are also are visible.

**(Refer Slide Time: 21:41)**

### Dovetail check

$$b = m - D(1 + \cot(\alpha/2)) + 2h \cot \alpha$$

b = width of top surface

m = measurement over balls

D = Ball diameter

h = Depth

$\alpha$  = Included angle

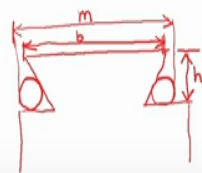

Now let us study about Dovetail check in most of the machine tools dovetail are used the dove tail they looked like this. Now this we have rollers or balls of same diameter kept in position like this and we can take the measurement over roller or ball so this will be m, so this is m is measurement over balls or rollers and then this is b width of top surface and this is h that is depth

$h$  and this is angle  $\alpha$ , this angle is  $\alpha$  and  $D$  is diameter of the ball the diameter of the balls.

Now by knowing any 4 out of these 5 parameters  $b$ ,  $m$ ,  $D$ ,  $h$   $\alpha$  you know any 4 parameter the other unknown can be calculated using this relationship.

**(Video Starts: 24:14)**

Now let us conduct an experiment are to check dovetail, now you can see here they have a dovetail here of milling machine we have kept a ball of known diameter on the other side also we have kept another ball of same diameter now we are measuring the  $m$  measurement over balls using the vernier caliper. I can see here we have kept another ball here and we are measuring the distance over the 2 balls.

You can see the measurement it is 242 millimeter and then they are to see the coinciding division it is 630 30 okay 242 plus we have to add the vernier scale reading. Now it can take be reading 242 millimeter and then 6th x 30th 30th division is coinciding with a main scale reading. Now we are taking the measurement over the top classes that is  $b$  you can see the reading so it is 195 + we have to see the coinciding division that is on 25th division is coinciding with the main scale marking.

I can see we are measuring the depth  $h$  we are measuring the depth  $h$  it is 22 millimeter Now we are measuring the diameter of steel ball.

**(Video Ends: 28:25)**

**(Refer Slide Time: 28:27)**

## Dovetail check

$$b = m - D(1 + \cot(\alpha/2)) + 2h \cot \alpha$$

b = width of top surface

m = measurement over balls

D = Ball diameter

h = Depth

$\alpha$  = Included angle

Now the measure the values can be fed into these this equation and unknown the value can be determined.

(Refer Slide Time: 28:38)

## Radius measurement

### Radius gauge

- A **radius gauge**, also known as **fillet gauge**, is a tool used to measure the radius of an object.
- Radius gauges require a bright light behind the object to be measured. The gauge is placed against the edge to be checked and any light leakage between the gauge and edge indicates a mismatch that requires correction.
- A good set of gauges will offer both convex and concave sections, and allow for their application in awkward locations.
- Every leave has different radius. The material of the leaves is stainless steel. It is of two types: 1. Internal 2. External. It is used to check the radius of inner and outer surfaces.

Now we are completed the first part of module 8 that is angle measurement, tilt measurement and paper measurement. Now we will move to the next part that is the radius measurement so for measuring the radius of a component the most commonly used instrument is radius gauge which is also known as the fillet gauge.

Which is used to measure the radius of an object radius gauge require a bright light behind the object to be a measure the gauge is placed against the edge to be checked and any light leakage

between the gauge and edge indicate the mix match which requires correction a good set of gauges will offer both convex and the concave gauges and allow for the application in awkward locations.

Every leaf has the different radius the material of the leaf is the stainless steel it is of 2 types internal the measurement leaf and the external measure that is concave measurement and convex the measurement is possible it is used to check the radius of inner and outer surface.

**(Refer Slide Time: 30:10)**



**Ranges available:**

0.5 to 13 mm (26 leaves : 0.5 to 13 mm in steps of 0.5 mm)  
1 to 7 mm (34 leaves : 1 to 3 mm in steps of 0.25 mm, 3.5 to 7 mm in steps of 0.5 mm)  
7.5 to 15 mm (32 leaves : 7.5 to 15 mm in steps of 0.5 mm)  
15.5 to 25 mm (30 leaves : 15.5 mm to 20 mm in steps of 0.5 mm, 21 to 25 mm in steps of 1 mm)

You can see here the set of radius gauges and here we have radius of different values is 10 millimeter radius 10.25, 10.5, 10.75 and like this, the different leaves are a commercially available and available ranges are like this 0.5 to 13 millimeter 26 leaves that is 0.5 to 13mm in steps of 0.5mm and 1 to 7 millimeter 34 leaves.

So 1 to 3 millimeter in steps of 0.25 millimeter 3.5 to 7 millimeter in steps of 0.5 millimeter and from 7.5 to 15 millimeter and from 32 leaves are available 7.5 to 15 mm in steps of 0.5 mm and then 15.5 to 25 mm totally 30 leaves will be available 15.5 mm to 20 mm in steps of 0.5 mm measurement is possible 21 to 25 mm in steps of 1mm measurement is possible.

**(Video Starts: 31:34)**

Now let us conduct an experiment to learn how we can use the radius gauge for measuring the radius now you can see our radius gauge set I can see different leaves 1 mm, 1.5 mm, 2 mm, 3

mm and here it is 6 mm leaf that means the radius is 6 mm, so the diameter will be 12 mm so this is were to check the concave radius and this portion can be used to check ready convex radius just 6.5 millimeter radius 6 millimeter 5.5,5 millimeter radius 4.5 millimeter radius 4 millimeter 3.5,7.58.

So like this different leaves are available 11 millimeter, 10.5, 10 millimeter. So leaves are available in type of 0.5, 11.5, 12, 12.5 and holder is provided along with the set to hold the leaf. Now we have to keep the gauge radius gauge into the holder. Now you can see how to use this radius gauge we have a threaded screw you want to measure the --- Now I can see there is proper match between the surface of the screw thread and the gauge, so the diameter is 12 millimeter.

Now let us learn how to check the concave radius I can see there is a slot we want to check you want to measure what is the diameter. Yeah now it is 7.5 it is properly matching with the contour.

**(Video Ends: 34:41)**

**(Refer Slide Time: 34:42)**

## Spherometer

- A **spherometer** is an instrument for the precise measurement of the radius of a sphere. These instruments are used by opticians to measure the curvature of the surface of lens.
- The usual form consists of a fine screw moving in a nut carried on the centre of a small three-legged table; the feet forming the vertices of an equilateral triangle. The lower end of the screw and those of the table legs are finely tapered, so that each rests on a point. If the screw has 1 mm pitch and head scale (dial) is divided into 100 parts, then the LC of the instrument is 0.01 mm. A vertical scale fastened to the table indicates the number of whole turns of the screw and serves as an index for reading the divisions on the head.

Now the under most commonly used instruments for the measurement of curvature of lengths of surface is the spherometer it is used for precise measurement of radius of a sphere these instruments are used by optician to measure the curvature of surface of lens. The usual form



consists of a fine the screw moving in a nut carried on the center of a small 3 legged table the feet forming the vertices of an equilateral triangle the lower end of the screw.

Those of the table legs are finally taper that means that the ends are conical so that each end rests on a point if the screw has 1mm pitch and the head scale that is dial is the divided into 100 parts then the least count of instrument is 0.01 millimeter A vertical scale fastened to the table indicates where the number of whole turns and serves as an index for reading the division on the head.

**(Refer Slide Time: 36:04)**

- An electric contact arrangement may be attached to the spherometer, in order to indicate the moment of touching, more precisely than is possible by the sense of touch. To measure the radius of a sphere—e.g. the curvature of a lens—the spherometer is levelled and read, then placed on the sphere, adjusted until the four points exert equal pressure, and read again. The difference gives the thickness of that portion of the sphere cut off by a plane passing through the three feet.

An electric contact arrangement may be attached to the spherometer, in order to indicate the moment of touching that is when the screw just touches the surface of the lens or work piece indicates that there is a contact so otherwise we can simple method is we can always take a feeler gauge or a piece of thin paper we should try to insert between the screw and the work piece surface if it enters it indicates that there is a gap if it does not enter it because that the screw is in contact with the work piece surface.

**(Refer Slide Time: 36:47)**

### Construction of spherometer

It consists of a base circle of three outer legs, having a known radius of the base circle. (The outer legs of some spherometers can be moved to a set of inner holes in order to accommodate smaller surface.)



- A central leg (screw), which can be raised or lowered.

- A reading device for measuring the distance the central leg is moved. The vertical scale is marked off in units of 1 mm. One complete turn of the dial corresponds to 1 mm and each small graduation on this dial represents 0.01 mm.

The spherometer directly measures  $h$ . Using the mean length between two outer legs,  $l$ , the spherical radius  $R$  can be calculated by the formula:

$$R = h/2 + l^2/6h$$

So now the construction of parameter is like the photograph shows that there is a central screw and 3 legs are there the screw is the screw end is conical, similarly all the 3 that they have conical end this is the dial on which the markings are there and then there is a vertical scale to indicate how many rotations this groove has rotated the 3 ends of the 3 legs form are the vertices of an equilateral triangle.

The outer legs that means these legs outer legs of for some spherometer can be moved to a set of inner holes in order to accommodate that smaller surfaces as we can see here there is a central leg that is the screw and there is a reading device for measuring the distance the central leg that is moved by what distance the central again move the vertical scale is marked of in units of 1 millimeter in the vertical scale.

1 complete turn of the dial corresponds to 1 millimeter and each small graduation on this dial that means this rotary scale represents 0.01 millimeter. This parameter directly measures  $h$  using the mean length between the outer length  $l$  the spherical radius  $R$  can be calculated by the formula  $R = h/2 + l^2/6h$ , so  $h$  is given by the spherometer using this relationship we can find the radius, radius of curvature.

**(Video Starts: 39:06)**

Now let us conduct an experiment to study how we can use a spherometer for measurement of radius of curvature. You can see we have a lens this parameter is placed on the length holds the

radius of curvature is to be determined. Now we are measuring the concave portion of there then I can see the screw end is in contact with the lens.

So that we can check this point screw point is in contact with the work piece or phase whether it is making proper contact or not that we can check by inside there to try to insert a piece of paper if it enters it indicates that there is gap if it does not enter it indicates that there is no gap. Now we have to take the reading on the vertical scale as well as on the dial rotary scale so this gives the h I can see the dial is reading 81 or 82.

Now we have to keep the spherometer on a plain paper and we have to press it to get the location of the legs 3 legs of the spherometer we have to mark those 3 points and then we have to join all these 3 points and then we should get the length of then l1 and l2 and length l3 and finally we should calculate the average length l.

So again we are trying to find the length l like to measure l1, l2, l3 and find the average now you can see we are measuring the radius of curvature of convex lens the screw should be withdrawn slightly and then this spherometer should be kept at the center screw end should be at the center 3 legs are in contact with lens.

Now we have to rotate the dial or screw so that it just touches the topmost point on the lens. Now we are rotating this screw, screw is moving down now it is making contact with the surface of the lens, now we have to note down the reading the dial reading as well as vertical scale reading Yeah dial reading and then vertical scale reading we should note down by knowing the h and l we can calculate the radius of curvature.

**(Video Ends: 43:30)**

**(Refer Slide Time: 43:41)**

## Calculation of radius of curvature (R)

### Calculation of R for convex lens:

$$h = \text{vertical scale reading} + \text{dial reading} \times \text{LC} = 1 + 92 \times 0.01 = 1.92 \text{ mm}$$

$$l = 45.0 \text{ mm}$$

$$R = \frac{1.92}{2} + \frac{(45 \times 45)}{(6 \times 1.92)} = 0.96 + 175.78 = 176.74 \text{ mm}$$

### Calculation of R for concave lens:

$$h = \text{vertical scale reading} + \text{dial reading} \times \text{LC} = 2 + 83 \times 0.01 = 2.83 \text{ mm}$$

$$l = 45.0 \text{ mm}$$

$$R = \frac{2.83}{2} + \frac{(45 \times 45)}{(6 \times 2.83)} = 1.415 + 119.258 = 120.673 \text{ mm}$$

Now the calculation of radius of curvature our calculation of radius of curvature for convex were done so we have observed that h that a vertical scale reading + dial reading x least count = vertical scale reading is 1 unit and then dial reading was 92 x least counting 0.01mm so h is 1.92 millimeter and average length that is distance between the tips of lens average distance is a 45 millimeter then we have to feed these values in the equation and finally we get radius of curvature of 176.74 millimeter.

Similarly for concave length h was 2.83 millimeter and l was the 45 millimeter, so radius of curvature was 120.67 millimeter like this using the spherometer we can find radius of curvature.

**(Refer Slide Time: 44:50)**

## Other uses of spherometer

It can be used to measure the thickness of a thin plate.

- The instrument is placed on a perfectly level plane surface and the screw turned until the point just touches. The dial and vertical scale are read; the screw is raised; the thin plate slipped under it; and the process is repeated. The difference between the two readings gives the required thickness.
- The instrument can measure the depression in an otherwise flat plate (the micrometer portion is placed over the depression and the measurement is taken below the surface instead of above).

Now what are the other uses of spherometer, so apart from measuring the radius of curvature this spherometer can also be used to measure the thickness of thin plate, thin metallic plates, thin glass plate, thickness can be measured the instrument is placed on a perfectly level plane surface and the screw turns until the point just touches the surface the dial and vertical scale are read and the screw is raised the thin plate is slipped under it and the process is repeated the difference between the 2 readings gives the required thickness.

The instrument can measure the depression in an otherwise the flat plate the micrometer portion is placed over the depression and the measurement is taken below the surface instead of above to check the depression.

**(Refer Slide Time: 45:48)**

## Cylindrometer

- Cylindrometer is a modified spherometer, which can measure the radii of cylindrical surfaces.



Now let us move to another instrument cylindrometer the spherometer used to check the to measure the radius of curvature whereas the cylindrometer is used to measure the radii of cylindrical surfaces it is a modified version of a spherometer the construction is shown here instead of 3 legs we have the totally 4 legs which are the 4 legs are fix to the base and this base has a vertical scale and at the center of the base.

We have a threaded screw and then a circular dial on which markings are there so similar to the spherometer this instrument can be used to measure the radius of cylindrical surface that means we have to say this is the cylindrical surface we want to measure the cylindrical the radius in we

have to keep this instrument on the surface and then the screw should be moved till it just touches the surface.

Then we have to take the reading vertical scale reading and then dial reading and then using the equation we can find the diameter of diameter or radius of cylindrical surface.

**(Refer Slide Time: 47:30)**

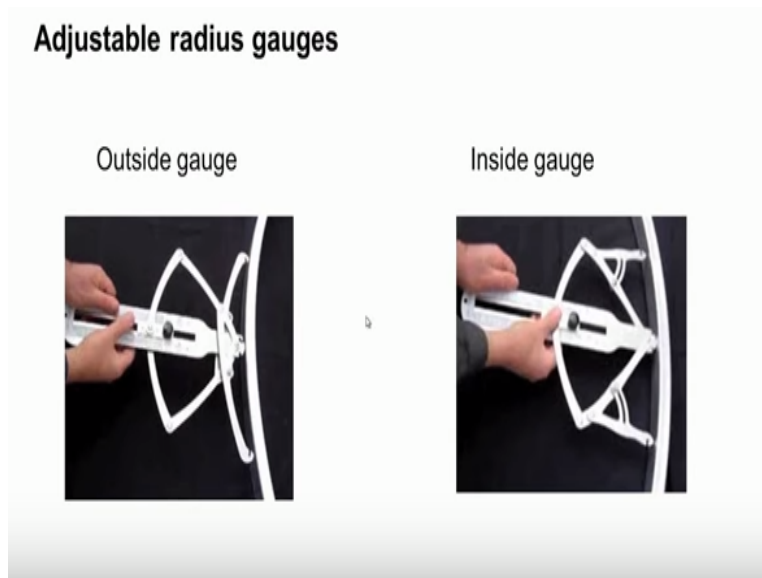

Now these are adjustable radius gauges there is outside gauge measure used to measure the convex work pieces radius of convex work pieces we can see here totally 3 points are there all these 3 points should be in contact with the work piece and then we should move this slide when the central point to just touches the work piece the scale indicates what is the radius similarly this is the inside gauge the 3 points should be in contact with the concave surface under the scale directly gives radius.

**(Refer Slide Time: 48:18)**

## Tool geometry

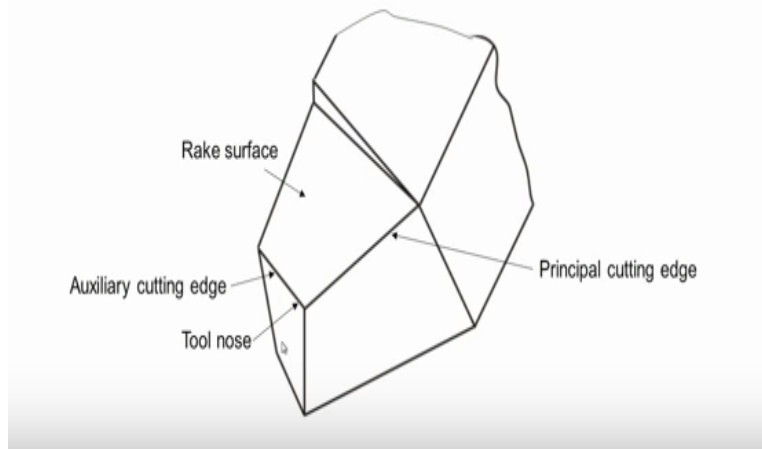

Now how do we measure the radius of tool tip, so this is a single point cutting tool and this is the principle cutting edge and a very cutting edge and here there will be a small radius is provided, so this radius we want to measure so for that we can use an optical the tool radius measurement setup this is the microscope which has a table on which we have to keep the cutting tool and then throw the eyepiece.

We can get the image of the nose and using the scale provided we can get the reading or we can put a camera here and then the amplified image we can have on the monitor and using a software we can now measure the diameter of the radius of tool what we can see here we have a tip tool with some radius so using the optical microscope like this.

We can measure the radius and again radius from the tool insert so radius measurement range of such a microscope the 10 micrometer to 20 millimeter with an accuracy of +/- 200 nanometer so setting times quickly we can measure the radius we are setting time is about 3 to 5 seconds.

**(Refer Slide Time: 50:00)**

### Digital radius gauge

A smart measuring instrument that measures the arc radius with different jaws (5 pcs). It tells outside or inside arc radius automatically, no calculation needed. Also, measures depth/thickness.



Range : 5 to 1000 mm

Resolution : 0.005 mm

5 measuring jaws: 10,20,30,60 and 100 mm

Now the other instrument used to measure the radius is digital the radius gauge, you can see we have an indicator with a spindle and then with the digital indica indicator and then we have a fixture with the 2 points 2 legs so this the picture we have to insert onto the spindle and we should keep this digital radius gauge there is the, the surface of the work piece well the radius of this prospect we want to measure this is the indicator distant ler indicator with to be spindle line we have to mount this picture the other 2 legs should be in contact okay.

Now we have slowly we have to move this spindle or because of a spring it moves down as it makes contact with the work piece and then the indicator will indicate what is the radius so different fixtures are available different jobs are available, so this tells outside or inside or radius automatically no calculation is needed directly it gives what is the value this.

We can also be used to check depth or thickness of objects range of such instrument is 5 t0 1000 millimeter with resolution of 0.005 millimeter so 5 measuring jaws are provided with a size 10 millimeter, 20 millimeter, 30 millimeter, 60 millimeter and 100 millimeter this gap is 100 millimeter.

**(Refer Slide Time: 52:21)**



## Profile projector



Then we can use a profile projector for measuring the radius, so we have to select appropriate function functional key in the data processor say we want to measure this radius where to feed 3 data points and then the data prophet will calculate and it will tell what is the radius whether it quick method or for measuring the radius.

**(Refer Slide Time: 53:03)**

## Profile projector

- Diameter/radius measurement using data processor
- Processing function keys:
  - Intersection angle between 2 straight lines (K): 4 points needed
  - To find diameter of circle (O): 3 points needed
  - To find distance of a point 1, from a straight line passing through 2 points (2 and 3)



So for measuring the diameter there to feed 3 points, so it will give the diameter of that will give this radius. Let us summarize this session for this lecture we discussed about the contact angle measurement and use of spirit levels for measurement of angles tilts also we learnt about how to use the autocollimator for measurement of for tilt and then we discussed about the measurement of radius.

What are the various instruments used for the measurement of radius instruments like spherometers, radius gauges, distal radius indicator and how to use profile projector for measurement of radius, so these things we discussed we will conclude this session. Thank you.