

**Cryogenic Engineering**  
**Prof. M. D. Atrey**  
**Department of Mechanical Engineering**  
**Indian Institute of Science, Bombay**

**Module No. # 01**  
**Lecture No. # 26**  
**Cryocoolers**

(Refer Slide Time: 00:31)

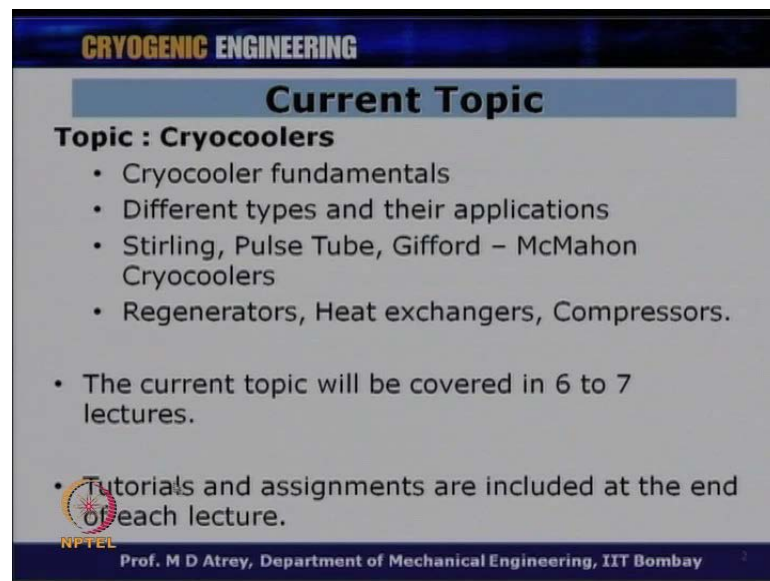

The slide features a dark blue header with the text "CRYOGENIC ENGINEERING" in yellow. Below the header is a light blue box containing the text "Current Topic". Underneath this is the text "Topic : Cryocoolers" in bold. A bulleted list follows, detailing the topics to be covered: Cryocooler fundamentals, different types and their applications (Stirling, Pulse Tube, Gifford - McMahon Cryocoolers), and Regenerators, Heat exchangers, Compressors. A note states that the current topic will be covered in 6 to 7 lectures. At the bottom, it mentions that tutorials and assignments are included at the end of each lecture. The NPTEL logo is visible in the bottom left corner, and the footer text reads "Prof. M D Atrey, Department of Mechanical Engineering, IIT Bombay".

So, welcome to the 26th lecture of Cryogenic Engineering, and here, we will be talking about a new model now which is Cryocoolers, which is I said new model, and this will consist of various sub topics and which would be covered over next six to seven lectures.

We will talk under cryocoolers; sub cryocoolers fundamentals, different types of cryocoolers and their applications. Then we will go in details of Stirling type cryocoolers, pulse tube cryocoolers, Gifford McMahon cryocoolers. When I said in depth means, we will not go to the design. We will go in details about Stirling Cryocooler, and I can give glimpses of how pulse tube cryocooler, G-M cryocooler work and thing like that.

Then we will also have a glimpse of various important parameters; very important sub parts of the cryocooler which is the regenerator, heat exchangers and compressor. At the same time, lot of work has been done at IIT Bombay, and I would like to show the cryocoolers being developed at IIT Bombay so that, we can get a direct field of the

hardware which has been developed at IIT Bombay. Also, we can see possibly a working cryocooler which can give you an impression about what is the cool down time, what is the temperature heat reaches, and thing like that.

This topic, we will try to cover in around six to seven lectures, depending on how we go through these topics. Again, we have got tutorials and assignments are included at the end of each lecture as what we have been doing till now.

(Refer Slide Time: 01:46)

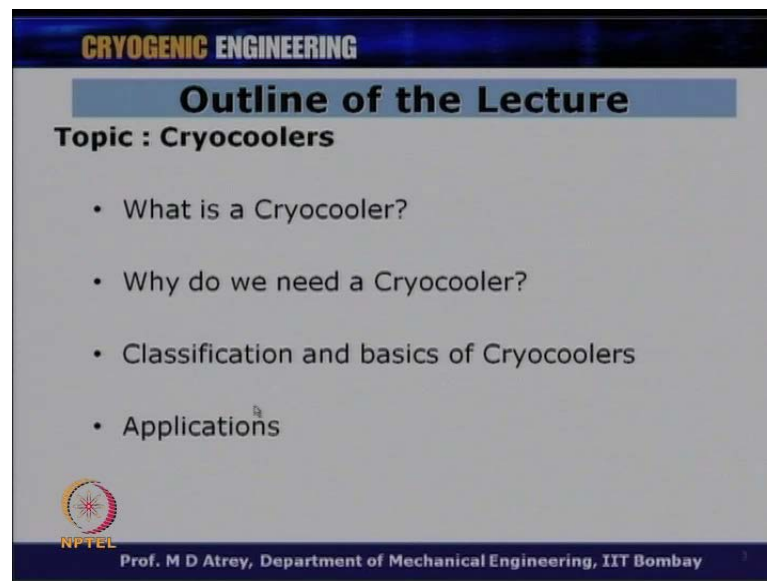

So, now coming to cryocooler, and the first lecture, we will talk about what is the cryocooler all right, how does it work, what are different types, and thing like that. So, what is the cryocooler, and importantly why do we need a cryocooler?

Cryocooler is basically a device which generates low temperature. So, what is the need when you have got a liquid nitrogen, liquid helium; all this cryogens which give low temperature, then why do we require a cryocooler?

Then we talk about classification and basics of different cryocoolers, and then lastly, I will just cover in a two or three slides, what are different applications of this cryocooler. They have got plenty of applications, but I cannot cover all of them in detail. So, I give you a field wise usage of this cryocoolers.

(Refer Slide Time: 02:28)

**CRYOGENIC ENGINEERING**

### What is a Cryocooler?

- A Cryocooler is a mechanical device which generates low temperature due to compression and expansion of gas.
- It operates on a closed cycle manner, which means the mass of the working gas is constant.
- A cryocooler consists of a compressor, a heat exchanger and an expander as shown in the schematic.

NPTEL  
Prof. M D Atrey, Department of Mechanical Engineering, IIT Bombay

Now, let us see, what is a cryocooler. So, Cryocooler is a mechanical device which generates low temperature due to compression and expansion of gas. Simple thing. It is like any other domestic refrigerator. A cryocooler actually is nothing but a refrigerator which gives you cryogenic temperature, which generates temperature in cryogenic range, and actually some people will call it Cryogenic Refrigerator also.

So, a Cryo Refrigerator, Cryogenic Refrigerator or a cryocooler; there are different names they will attribute to this device, but essentially what it does is, it works like a domestic refrigerator. There is a compressor, there is a heat exchanger, and there is an expansion device.

So, you can see here, in this particular schematic, what you have is a compressor, then heat exchanger, then this expansion device, and lastly, we have got evaporator to do the heat exchange with the object to be cooled. So, this operates in a close cycle manner. So, you can see the arrows in both the direction. So, gas gets compressed, comes to heat exchanger, exchanges heat, gas gets expanded, produces cold, gives the cold to the object be cooled, and the gas goes back and the cycle continues.

So, important thing about Cryocooler is, it operates in a close cycle manner; which means, the mass of the working gas is constant. So, once you charged the cryocooler like again in a domestic refrigerator which also works in a close cycle manner, if I charge

some amount of gas, this gas will be compressed and expanded which generates low temperature.

So, once you charge the cryocooler with a given amount of gas, it will work in a close cycle manner, and generate a cryogenic temperature, and whatever object you want to cool, if you want to cool the gas, if you want to liquefy the gas, that is also possible using a cryocooler.

So, cryocooler can also work as a liquefier, provided it generates that much amount of cold or cooling effect or refrigeration effect. So, they said it operates in a close cycle manner which means the mass of the working gas is constant.

A cryocooler consist of a compressor, a heat exchanger and an expander as shown in the schematic. So, when I say expander, actually it houses both expansion device as well as evaporator; it combines and this can be called as an Expansion unit.

(Refer Slide Time: 04:37)

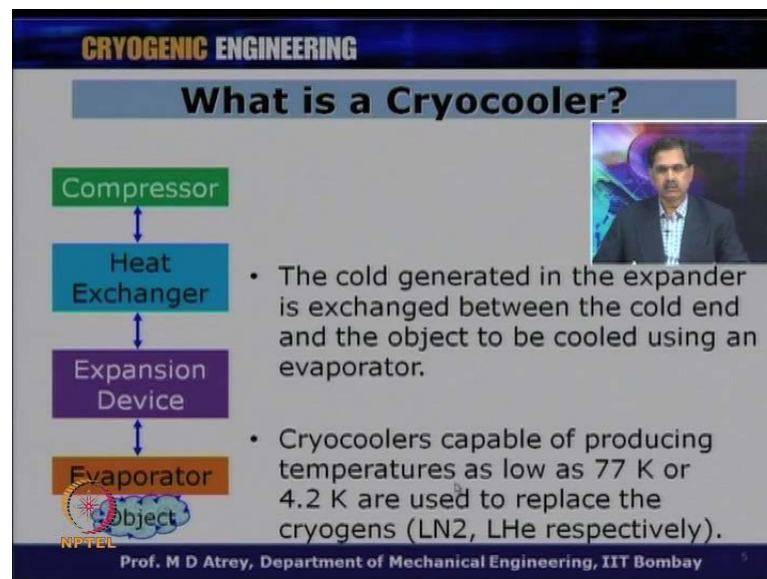

The cold is generated in the expander. So, the lot of cold generated in the expander which houses both expansion device as well as evaporator is exchanged between the cold end and the object to be cooled. So, whatever object to be cooled, this object will be over here. So, you see actually evaporated is nothing but a kind of a heat exchanger which transfer this cold to the object to be cooled, all right. So, this is the close cycle manner in

which the cold will be generated, and it will exchange this cold through evaporator to the object to be cooled.

So, cryocoolers are capable of producing temperature as low as 77 Kelvin or below 4.2 Kelvin, not only 4.2 Kelvin, but below 4.2 Kelvin, and they will be used to replace the cryogenics. So, at many places, you cannot go for liquid nitrogen or liquid helium or liquid hydrogen for that matter, you know, because of the availability and because this cryogenics cannot reach there in time. So, what do we do, we use a cryocooler; it generates whatever temperature is of your interest, any temperature from you know in cryogenic zone below 120 Kelvin.

A cryocooler can be designed for that particular application to generate that much of cold and it can therefore, replace whatever was earlier done using the liquid helium or a liquid nitrogen or a liquid hydrogen. So, that is the very important usage of cryocooler. Like a domestic refrigerator, it can generate... domestic refrigerator is main for particular purpose where cryocoolers can be designed for a particular purpose. It can be customized for a particular purpose to generate a given temperature and also to generate given cooling effect. It is very important.

(Refer Slide Time: 06:11)

**CRYOGENIC ENGINEERING**

## Why a Cryocooler?

**'Earth's Helium Reserves To Run Out By 2030'**  
Aug 23rd, 2010 (PT)  
Tags: 2030, Earth, Helium

The article shown here is extracted from Asian Age, 23rd Aug' 2010.

Earth's helium reserves will run out by 2030, a leading expert has claimed. According to Nobel laureate Prof. Robert Richardson of Cornell University, the US supplies 80 per cent of the helium used in the world at a very cheap rate and these supplies will run out in 25 to 30 years' time. And, since the helium reserves are gone, there will be no way of replacing it, the Professor of physics said. "There is no chemical means to make helium. The supplies we have on Earth come from radioactive alpha decay in rocks. Right now it's not commercially viable to recover helium from the air so we've to rely on extracting from rocks. "But if we do run out altogether, we will have to recover helium from the air and it will cost 10,000 times what it does today," Prof Richardson told the 'New Scientist'. A US law states that the biggest store of helium in the world — in a disused airfield in Texas — must be sold off by 2015 and is being sold at far too cheap a price. This means that the Earth's resources of helium are being depleted at an astonishing rate because it is too cheap to recycle. Helium is formed on Earth as rocks steadily decay and nearly all of our reserves have been formed as a by-product of the extraction of natural gas. The only way to obtain it will be to capture it from the decay of tritium — a radioactive hydrogen isotope, which the US stopped making in 1993. So what should we do? "Get out of the business and let the free market prevail. The

According to Prof. Robert (Cornell Univ.), Helium reserves would run out by 2030.

Hence, closed cycle cryocoolers, generating low temperature is the need of time.

NPTEL  
Prof. M D Atrey, Department of Mechanical Engineering, IIT Bombay

So, why do we require a cryocooler, and I will just go through a title of this particular paper, this article shown here is extract from a Asian Age on 23 august 2010. What does it says? It says that "Earth's Helium Reserves to run out by 2030".

Earth Reserves are obtained mostly in USA through the rocks or through the you know different springs, hot springs over there, and this helium reserve is getting depleted over period of time. You know the helium gas is very costly. So, if I want to use liquid helium, the cost of Liquid helium is going up and up.

So, if I want have a 4.2 Kelvin, I have to really pay a lot of amount. Instead, can I use now a cryocooler which generates the same temperature, and because why this application is felt very very importantly right now is because of this reason that helium reserves are getting run out. It is running out by 2030. So, According to Professor Robert, who is from Cornell University, Helium Reserves would be running out from 2030 and therefore, the close cycle cryocoolers will replace liquid helium.

What was previously done with liquid helium? Because the cost of liquid helium is going to go up and up all right. It is very difficult to extract helium from air. The cost of extraction of helium gas from air is ten thousand times more and therefore, whatever helium reserves are available right now, in the rocks for example, because this is getting depleted, the cost of helium is going to go up and up, and that can be completely replaced or its function can be completely replaced by using a close cycle cryocooler or a cryocooler.

We generate the same temperature, and this is the need of the time. This is very important function and therefore, most of the Cryogenic application would now use instead of liquid helium, they will try to use liquid helium.

So, it is a very important fact, a cryocooler can actually, it can do away with the usages of liquid nitrogen and liquid helium.



(Refer Slide Time: 08:07)

**CRYOGENIC ENGINEERING**

### Why a Cryocooler?

- No Cryogen requirement.
- Cryocoolers offer reliable and maintenance free operation.
- The cost of cryogen is increasing, whereas the cost of cryocooler is decreasing.
- There is a scope for new technology which would advance development towards invisible cryogenics.

**NPTEL**  
Prof. M D Atrey, Department of Mechanical Engineering, IIT Bombay

So, why a cryocooler? Again taking the same part, same topic ahead, why a cryocooler; importantly I just pointed out; if I use a cryocooler, I may or may not require a cryogen now. It is a very important. I may not require liquid helium now which is a most costly cryogen right now.

So, a Cryocooler can function to produce a temperature which was otherwise given by a liquid helium. So, in this case, I will not require any cryogen. Cryocoolers offer reliable and maintenance free operations. Because of the you know, usage over a product time, cryocoolers have become very very reliable and maintenance free now, and therefore, they are acceptable in most reliable functions required. For example, in medicine for example, in health care unit where reliability plays a very important role, and cryocoolers have been accepted over there.

The cost of cryogen is increasing whereas, the cost of cryocooler coming down. This is the very important parameter. As I said, because of the helium reserves are depleting, the cost of cryogen is increasing with time. There are different various losses in transferring of cryogen. This is safety requirement again while transferring cryogen. Plus in addition that this gases are becoming rare for example, Helium, neon, etcetera.

Why? The cost of cryocooler is coming down because more and more cryocoolers are made and therefore, the production cost are coming down, and lot of new technologies are coming into picture, and therefore, the cost of cryocooler is coming down which is

again a good reason to replace cryogenics; what was previously done by cryogenics, now cryocoolers can do the same important thing.

There is the scope for new technology which would advance development towards invisible cryogenics. Now this is a very important statement. The cryocooler technology has always been a dynamic technology, and every time if you go for a conference, every time you find something new is happening, something new has come in this field and therefore, this technology is always becoming now better and better efficient and efficient.

And therefore, this is a very very important thing that the technology is becoming better and better with time, and also for example, the physics people or the health care unit; they do not want to know about cryogenics. They want low temperature, no matter how you get it, but they do not want to see the cryogenics associated with that thing because for example, in hospitals, they want low temperature to perform surgery for example, or Run a MRI machine. They are not bothered about how you generate low temperature.

So, a new phrase is we would like to go towards invisible cryogenics; that means, if I am a user from physics department or from let say from medicine side, what I want is, I want low temperature, and I do not want to worry about how do I get low temperature; that means, cryogenics for me should be invisible, and this is where everybody would like to go. The cryogenics should become invisible and a reliable and maintenance free; cryocooler can do the same thing basically. So, this is what we are aiming for.



(Refer Slide Time: 10:56)

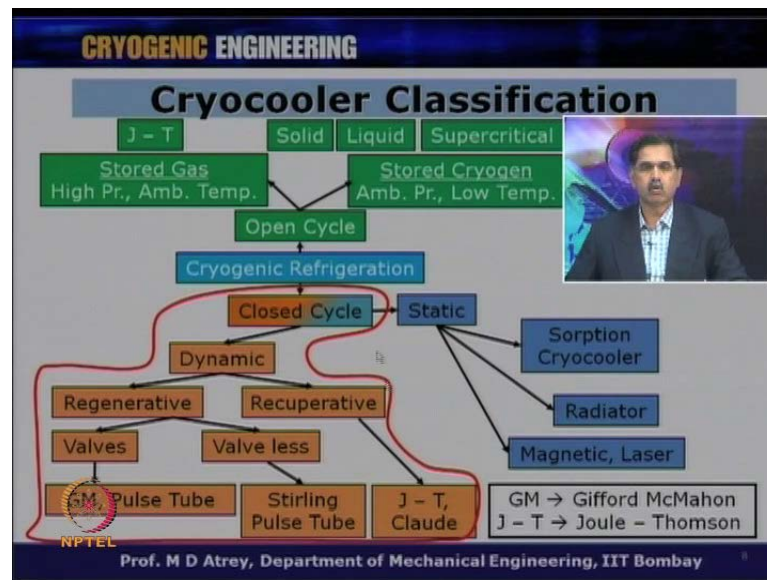

Now, coming to cryocooler classification. If I see cryocooler classification, the cryocoolers can be classified based on how you get cryogenic refrigeration. So, this is the most important thing. So, I can get cryogenic refrigeration in two ways: one is by open cycle, the other one is by closed cycle. Please understand this slide very importantly now.

So, if I want something to be delivered at 4 Kelvin, 10 Kelvin, 25 Kelvin, 30 Kelvin or 80 Kelvin whatever; we can get this cryogenic refrigeration by two ways; one is by having open cycle, one is by having a close cycle.

When I say open cycle; that means the gas or cryogen which is used, is open to atmosphere, the gas is delivered to atmosphere. Close cycle as I said, the cryocoolers where the gas or whatever cryogen we use, works in a closed cycle manner. It is not left to that atmosphere again.

Let us come to the open cycle, and under open cycle now, we can use stored gas or stored cryogens. So, I can have a stored gas, and under stored gas, I can have a Joule Thomson Cryocooler; a J-T is nothing but Joule Thomson Cryocooler. I can expand this stored gas from high pressure and expand the gas from higher pressure to low pressure; during which I get a cooling effect, and this cooling effect is delivered to whatever to be cooled; that means, I will get cryogenic refrigeration, and this gas is let go to that atmosphere.

For example, I can use nitrogen here. Nitrogen at higher pressure, going through a small constriction or a capillary tube, expands it gives the cold, and the gases left to atmosphere, and this is what we call as open cycle. The other part is instead of stored gas, I can go to stored cryogen. I can use liquid nitrogen, liquid helium for example, I can use this to cool whatever object I want to cool, and this gas, after delivering the cooling effect, it can again let go to that atmosphere, all right. So, that is why we call it Open Cycle.

We do not collect it back, and compress it back and thing like that. So, here, I can use solid cryogen, liquid cryogen, super critical cryogen. So, stored cryogen I can use in any form. If I go on cooling further, I will get solid nitrogen here, which possibly will happen before below 63 Kelvin, and this solid nitrogen also could be used to deliver cooling effect. I can use liquid nitrogen. I can use compressed super critical nitrogen gas to deliver this cold, all right. So, these are different ways of getting open cycle, to get cryogenic refrigeration by using an open cycle.

Now, let us come to close cycle. Under close cycle, we have got two possibilities; we have got a device which works in a dynamic way. We have got a device which works in a static way. When I say it dynamic way and static way, I am talking about a moving component. When I say dynamic; that means, something is moving; either the compressor piston or expander or whatever it is. There is a one part which is always in motion, while static nothing is moving.

So, ideally, I will prefer to have a static because the moment there is a no moving part, there is no ..., there is the maximum reliability, there is no wear and tear. So, static is the most sort for, but it has got its own problem. So, dynamic delivers cold very fast in more efficient also, but in you have to pay for it, because they will be always be some wear and tear.

So, we have got a dynamic possibility; dynamic close cycle or a static close cycle device, and under these devices now, under dynamic for example, we have got different classification based on the heat exchanger it uses. As I said, every refrigerator or every cryocooler will have a heat exchanger, and this heat exchanger will be of could be of recuperated type or a regenerated type. We will talk about this in detail.

So, depending on the kind of heat exchanger they use, they can be further classified as a regenerative cryocoolers or a recuperative cryocoolers. Under regenerative now, I can have valves between the compressor and expander, and I can have valve-less unit between the compressor and the expander. So, this also makes a difference because whenever valves come, efficiencies are a problem.

And under valves now or under valve-less system, what you have is different types of cryocoolers, and under valves, what we have is the G-M- Gifford McMahon cryocooler and we have got a Gifford McMahon type pulse tube Cryocooler here, while a valve-less unit is always a Stirling cooler or a Stirling type pulse tube cooler, and we will go through details of this, because a cryocooler is a part which is dealing with this quadrant here, all right. So, we will go through this more in the coming lectures.

And recuperative, what normally you have is a Joule Thomson or a Claude cryocoolers. We have dealt with Claude's cycle and J-T Cryocoolers earlier. So here, pointing out G-M is nothing but Gifford McMahon, J-T is nothing but Joule Thomson cryocoolers. So, this is what we will be dealing with in the next four five lectures, while under static, we have got a various possibilities. As I said, in static cryocoolers, nothing is moving and therefore, we can have a sorption mechanism, where gas is actually adsorbed on the sorption material. And therefore, sorption cryocoolers; we can have radiative cryocooling which normally uses a space, we have got a magnetic refrigeration, we have got AC cooling due to lasers also.

Most of you possibly will may have heard about these kinds of cooling devices; based on the principles, I am writing here. So, we have got a no part in this case is moving and therefore, we got a maximum reliability. Only thing what you require is very high cost sometimes or the system could be very very less efficient in this case. So, as far as these lectures or this module is concerned, we are going to talk about this third quadrant. If I call this as third quadrant, whatever has been enclosed here, this is what we are going to talk about in this module of cryocoolers.

(Refer Slide Time: 16:38)

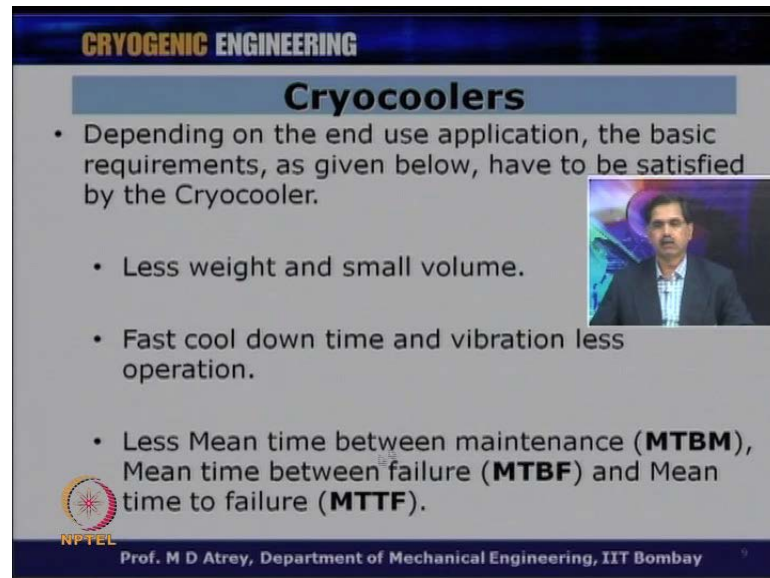

The slide is titled "CRYOGENIC ENGINEERING" and "Cryocoolers". It lists the following requirements for cryocoolers:

- Depending on the end use application, the basic requirements, as given below, have to be satisfied by the Cryocooler.
- Less weight and small volume.
- Fast cool down time and vibration less operation.
- Less Mean time between maintenance (**MTBM**), Mean time between failure (**MTBF**) and Mean time to failure (**MTTF**).

The slide also features a small portrait of Prof. M D Atrey and the NPTEL logo.

Now, depending on the end use application, the basic requirement as given below have to be satisfied by the cryocoolers. So, what are these requirements to be satisfied by the cryocoolers. It has to have less weight and small volume depending on end use. For example, it can be use a space application where the weight and the volume also are very very important.

Fast cool down time and vibration less operation; this is also very important characteristics. How much time it takes when it started, how much time it takes to reach down to the lowest temperature, and also what is its vibration level, noise level. This also a very important parameters depending on the kind of applications you have in mind.

Now, different parameters associated with the maintenance and life is basically MTBM- the mean time between maintenance should be has minimum, mean time between failure should be minimum, as well as mean time to failure; these are typically MTBM, MTBF and MTTF are the terms which are talked about, when we talking about its life, and this should be definitely this should be very very high.

(Refer Slide Time: 17:37)

**CRYOGENIC ENGINEERING**

## Cryocoolers

- Continuing further, the basic requirements of a Cryocooler are:
  - Minimal effect of orientation, gravity, acoustic noise and electromagnetic interference.
  - High reliability and shelf life
  - Cost effective as compared to existing systems.

**NPTEL**  
Prof. M D Atrey, Department of Mechanical Engineering, IIT Bombay 10

Continuing further, the basic requirements of a cryocooler are, if I want to technically see what are cryocooler requirements, it should have minimal effect of orientation. Sometimes, the cryocooler or some of the cryocoolers do not work, when their orientation is not vertical. If they are inclined, for example, pulse type cryocooler which we will see, it has got orientation effect, acoustic noise, electromagnetic interference, because some parts are moving all the time, and therefore, the devices around this cryocooler can also show some problems because of the interference.

So, you have to worry about in what environment these cryocoolers are going to work, and accordingly, one has to choose or one has to shield these cryocoolers. The cryocoolers of course, should have high reliability and shelf life, cost effective as compared to existing systems now. Sometimes, these cryocoolers can be very costly, depending on now what temperature you want to use and different customizations can be made and therefore, the cost effectiveness of this cryocooler has to be justified, and this is the normal parameters which one has to consider when one chooses or buys a cryocooler.

(Refer Slide Time: 18:40)

**CRYOGENIC ENGINEERING**

### Technical Parameters

- The technical parameters that govern the choice of a Cryocooler are as given below.
  - Cooling effect : \_\_\_\_\_ mW(W) @ \_\_\_\_\_K.
  - Compressor power requirement \_\_\_\_\_W(kW).
  - Cooling water requirement.
  - Service requirement of compressor.
- Vibration level and cost.

**NPTEL**  
Prof. M D Atrey, Department of Mechanical Engineering, IIT Bombay

Now, what are technical parameters? When I buy a cryocooler, or when I you know decide to design a particular cryocoolers, what are the technical parameters that govern the choice of a cryocooler. See, if I want to design a Cryocooler or if I want to buy cryocooler, what are various parameter I will look for.

So, important thing is cooling effect, and cooling effect is how many mille watts of cooling effect at a particular temperature, or how many watts of cooling effect at a particular temperature. For example, I require 50 mille watts at 80 Kelvin do I want it, if I want to use this thing, this is my design specifications.

So, one has to really know and mind you that, for this we are paid. If I say, instead of 50 mille watt, I want 500 mille watt, the cost of the cryocooler will be very very high. So, therefore, one should be clear for what exact end use application a cryocooler has to be designed or Cryocooler has to be bought. There is no point in buying a very high capacity cryocooler, if our requirements are very very low, because one will pay for this cooling effect, because the size of the compressor, size of expander, size of entire cryocooler will change as soon as one demands higher cooling effect at any temperature.

The next parameter which is very important is, what is the compressor power requirement. It could be in watts, it could be in kilowatts. So, to obtain this cooling

effect, compressor power also is to be you know decided. In fact, these upon these is nothing but the c o p of a cryocooler, isn't it.

So, compressor power requirement is a very critical parameter because the power requirement sometimes could be available or may not be available depending on in what environment you working. Do you have a three phase requirement for example, all right, do you have a single phase requirement; this is also a very important parameter when one decide to buy a cryocooler.

Now, many times, the compressor needs to be cooled. That is the after cooler. Do we require a cooling water, do we require chill cooling water, chill water requirement. So, when I buy a bigger compressor, I may go for cooling water requirement, and therefore, I will require a chiller, and that is also an additional cost. So, I should know do I require. Is it an air cooled compressor or a water cooled compressor. There are different parameters associated with these, and one should be aware of all these technical parameters.

Again, one has to worry about service requirement of a compressor because this compressor could be oil filled compressor. The moment there oil filled, the oil needs to be change over a period of time or even the adsorbers needs to be cleaned or replaced over a period of time, and this talks about service requirement. May be after ten thousand hours of working or fifteen thousand hours of working, this is required to be done, and therefore, one has to know what are the service requirement because, when the compressor is being service, your cryocooler will be down, and if your application for example, is in health services, the down time is very costly. So, one should be aware of such parameters, and of course, the vibration level and cost which I have talked about; all this will constitute kind of technical parameters or it will govern the choice of a cryocooler to be used for a particular application in mind.



(Refer Slide Time: 21:31)

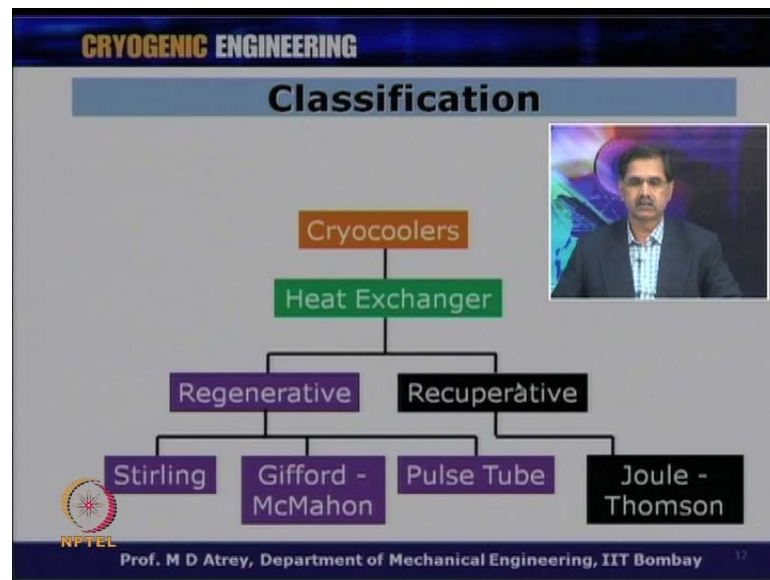

Now, let us come to the classification of cryocoolers, and as I said earlier, the cryocoolers are classified based on the kind of heat exchanger it uses. So, every cryocooler will have some kind of heat exchanger, and every heat exchanger, the heat exchanger could be of two types; a Regenerative type and Recuperative type. I will talk about this in the next slides.

So, if we have got regenerative type of heat exchanger, then we can have different cryocoolers like. We can have Stirling cryocooler, Gifford McMahon cryocoolers and pulse tube cryocoolers. They all come under category of **...** they all use regenerative heat exchanger to cool the gas where heat exchange happens, while a recuperative heat exchanger, under this category what falls is, Joule Thomson Cryocooler and Claude cycle and Brayton Cryocoolers. Also I will talk about this.

So, this is the very important cryocooler case which uses regenerative cryocoolers; regenerative heat exchanger based cryocoolers and sometimes they are called as regenerative type cryocoolers also, while this is the recuperative type of cryocoolers. So, based on the heat exchanger the cryocoolers use, we have got a regenerative heat exchanger, the recuperative cryocoolers and different types of cryocoolers come under that.

(Refer Slide Time: 22:44)

**CRYOGENIC ENGINEERING**

## Heat Exchanger

- A heat exchanger is a device in which the warm fluid gets cooled due to heat exchange with the cold fluid.
- In most of the cases, the process of heat exchange occurs at a constant pressure.
- It can either be a regenerative or recuperative type of heat exchanger depending on the kind of heat exchange between the fluids.



**NPTTEL**  
Prof. M D Atrey, Department of Mechanical Engineering, IIT Bombay 13

So, a heat exchanger is a device in which the warm fluid gets cooled due to heat exchange with cold fluid, as you know this. In most of the cases, the process of heat exchange occurs at a constant pressure. It can either be a regenerative heat exchanger or recuperative heat exchanger depending on the kind of heat exchange between the fluids. So, you know the basics of heat exchanger, where warm and cold fluid exchange heat.

(Refer Slide Time: 23:06)

**CRYOGENIC ENGINEERING**

## Heat Exchanger

### Recuperative HX

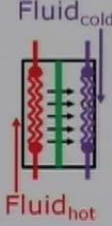

- In a recuperative heat exchanger, the flow direction of two fluids is constant and is simultaneous.
- The two fluids are separated by a solid boundary across which the warm and cold fluids exchange heat.
- The direction of the fluid flow may either be counter flow, cross flow or parallel flow as explained in earlier lectures.

**NPTTEL**  
Prof. M D Atrey, Department of Mechanical Engineering, IIT Bombay 14

Now, in a recuperative heat exchanger, the flow direction of two fluid is constant and is simultaneous. So, you can see that, this is a recuperative type of heat exchanger where

the hot fluid goes and the cold fluid comes down, and this direction of hot fluid always constant. It will not change over a period of time, and both these fluid; the hot fluid and the cold fluid are moving simultaneously; both of them are present at the same time.

The two fluids are separated by solid boundary across which the warm and cold fluids exchange heat. Now this is also very important. There is the cold and hot fluids are actually segregated. They are away from each other and the heat exchange happens between some cooperative for example.

So, we can have a tube in which one tube is housing a hot fluid, the other tube is a cold fluid, and through the thickness of this tube or the surface area of this tube, the heat exchange is happening. So, actually they are basically separate. They are housed in a separate tubes sometimes or separate channels or separate sections.

The direction of the fluid flow may be either counter flow, cross or parallel flow as explained in earlier lectures. We shall be seeing my liquefaction lectures. We have talked about all the recuperative heat exchanger there, and these directions can be parallel to each other cross flow, counter flow kind of recuperative heat exchangers. So, these are the recuperative heat exchanger which are normally use in Joule Thomson cryocooler.

(Refer Slide Time: 24:21)

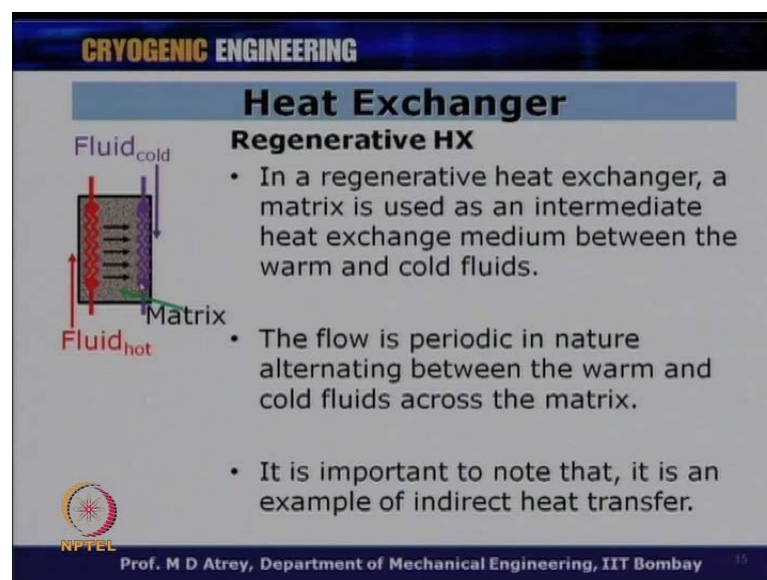

**CRYOGENIC ENGINEERING**

## Heat Exchanger

### Regenerative HX

- In a regenerative heat exchanger, a matrix is used as an intermediate heat exchange medium between the warm and cold fluids.
- The flow is periodic in nature alternating between the warm and cold fluids across the matrix.
- It is important to note that, it is an example of indirect heat transfer.

**NPTTEL**  
Prof. M D Atrey, Department of Mechanical Engineering, IIT Bombay 15

Now, let us see regenerative heat exchanger, and in the regenerative heat exchanger, a matrix is used as an intermediate heat exchange medium between the warm and cold

fluid. So, we can see here, in addition to the warm fluid and the cold fluid, what you have is a matrix in between. So, what happens here, the flow is periodic; that means, I will have a hot fluid going through first for some time, and this hot fluid will give the heat to the matrix, and this matrix will take the heat and store the heat.

After sometime, when the hot fluid has gone, the cold fluid will come which could be the same fluid at lower temperature or a different fluid also. This cold fluid will come, and this cold fluid will pass through the regenerator, and it will take heat from this matrix, and it will get warmed up during this period. So, we got a hot flow forward by a cold flow and hot and the cold fluids are actually not moving at the same time.

What does it mean? It means that there oscillating flows. The flow is in this direction for some time and flow then in this direction is stop; it will come to zero, and then the cold fluid will start after some time. So, it is very important to understand that the heat exchange is happening through a matrix, and therefore, we say that the flow is periodic in nature. So, in this case, the flow is periodic in nature, alternating between the warm and the cold fluids across the matrix.

It is important to note that, it is an example of indirect heat transfer; that means, there is no direct heat exchange between the warm fluid and the cold fluid. The warm fluid gives the heat to the matrix, and then the matrix passes this heat to the cold fluid. So, there is the indirect heat transfer between the hot to the cold fluid through the matrix. This is the way the regenerative heat exchangers work.

(Refer Slide Time: 25:59)

**CRYOGENIC ENGINEERING**

### Recuperative Cryocoolers

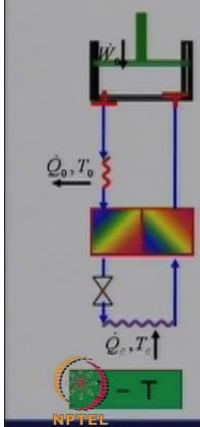

- The first recuperative Cryocooler shown here is the Joule – Thomson Cryocooler (J – T Cryocooler).
- The gas is compressed in a reciprocating compressor and is expanded isenthalpically (based on inversion temperature) in the J – T valve as shown in the schematic.
- The hot and cold fluids exchange heat in a recuperative heat exchanger.

NPTEL  
Prof. M D Atrey, Department of Mechanical Engineering, IIT Bombay 16

Now, in the recuperative case, if I want to see now recuperative cryocooler, you have got a compressor, heat exchangers and Joule Thomson expansion. So, this is a Joule Thomson cryocooler which uses a recuperative heat exchanger.

The first recuperative cryocooler shown here is a Joule Thomson cryocooler which we have seen earlier in a Linde Hampson cryocoolers also, the cycle also. The gas is compressed in a reciprocating compressor and is expanded isenthalpically, based on its inversion temperature. If you remember, the Joule Thomson cooler will produce low temperature only when the gas temperature is below its inversion temperature, and you get the cooling at this point.

So, simple Joule Thomson cryocooler will have a compressor or you get a high pressure side and low pressure side with valves over here. You can see, the high pressure gas will come, it will get expanded by this expansion device, produce the cold and the low pressure gas will go back. Through a recuperative heat exchanger, it will pre-cool these incoming high pressure gas, and it will go back, and cycle will continue. This is the way a Joule Thomson cryocooler work. The hot and cold fluid cold exchange heat in a recuperative heat exchanger in this case.

(Refer Slide Time: 27:01)

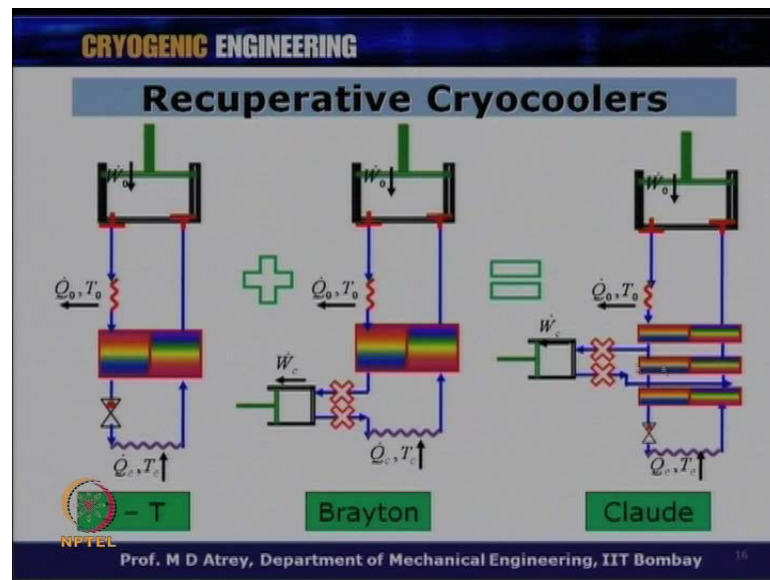

Now, you can (( )) the second cycle which is Brayton cycle. Instead of having this valve, we can have an expander which is a moving expander, and it has got an inlet valve and exhaust valve. And depending on this expansion, this will produce work output over here. This will not produce work output here, but this will work output, and therefore, what we call is a Brayton cycle.

And third cycle will be a combination of this. So, this cycle is a Brayton cryocooler cycle similar to Joule Thomson cryocooler, except that the expansion device produces work, and third is a combination of this two. So, we have got a Brayton work output also, at the same time, we got a J-T also, and we have got a three recuperative heat exchanger and this is what we have explained earlier; Claude cycle if you recollect, all right. So, we have got three devices, three different cryocoolers which work on recuperative cryocoolers.

(Refer Slide Time: 27:57)

**CRYOGENIC ENGINEERING**

### Regenerative Cryocoolers

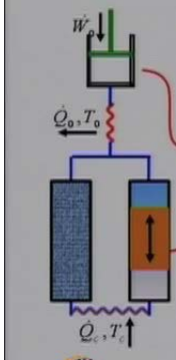

- The schematic of a Stirling Cryocooler is as shown.
- It consists of a compressor, a regenerative heat exchanger and a displacer.
- The compressor piston and the displacer maintains a fixed phase angle between their motion.
- This phase difference is vital to have an efficient operation.

**Stirling**  
NPTEL

Prof. M D Atrey, Department of Mechanical Engineering, IIT Bombay 17

So, the next type of cryocoolers now we have is a regenerative cryocooler. As I said, the regenerative cryocooler we use regenerative heat exchanger, and there of various types.

So, here we will deal with first what we call as Stirling type cryocoolers or Stirling cryocoolers here. So, here you can see that, the schematic which shown, we have got a compressor here, and the compress gas will come through the regenerator. This is the regenerative heat exchanger.

At the same time, what we have got is something called as displacer which is also moving. The compressed gas will come over here, the heat of compressor will be removed in this after cooler here, the gas will come to the top of displacer over here, and during the motion of this displacer, this gas will be pushed and this will come through regenerator, and the gas will come to the expansion phase over here.

And as soon as the pistons go back, the gas will be expanded at this point. When the displacer comes to down, this gas will go back and the cooling effect will be delivered in the evaporated at this prime. We will go through the details of working of this Stirling coolers, but just to tell you that, there are two moving components here; one is the compressor piston and expander or a displacer at this point. This displacer is just displacing the gas when it comes to the expansion chamber over here or expander over here, this expansion volume; it will just force the gas to go out. Piston compresses the gas, while displacer just displaces the gas. It is not compressing.



So, it will just displace this gas from these. It will come through regenerator come through the expansion volume or expansion chamber. The gas will get expanded depending on the motion of the piston at this point, and then the displacer will come down, and it will push this cold gas out delivering the cold effect at this point here. Evaporator is housed over here, and this is the way, the Stirling cooler works.

So, it consists of a compressor, regenerative heat exchanger and a displacer. And the compressor piston and a displacer maintains a fixed phase angle between their motion. So, this red line shows the relationship between the compressor piston and the displacer. this is the very important design aspect, if they are in phase, they will not produce any cooling effect at this point, and therefore, a very important or very fixed phase angle, a correctly maintained phase angle between the motion of the piston and the displacer will be maintained over here, and that is a part of your design parameters which will produce cooling at this point. This phase difference is vital to have an efficient operation.

(Refer Slide time: 30:17)

The slide, titled "Regenerative Cryocoolers", compares two types of cryocoolers. On the left is a Stirling cryocooler, and on the right is a Gifford-McMahon (G-M) cryocooler. Both diagrams show a compressor at the top, a regenerator in the middle, and a cold chamber at the bottom. The Stirling diagram shows a single line connecting the compressor and cold chamber, while the G-M diagram shows two lines. A red line in both diagrams represents the phase relationship between the compressor piston and the displacer. The slide includes the following text:

- The schematic of a GM Cryocooler is as shown.
- The required phase difference is maintained by relative motion between the valve mechanism and the displacer motion.
- Stirling Cryocooler works at high frequency, while GM Cryocooler works at low frequency.

At the bottom of the slide, it says "Prof. M D Atrey, Department of Mechanical Engineering, IIT Bombay".

Now, the next cryocooler what we call is a Gifford McMahon cryocooler, and what you can see here, there is a only one line; high pressure, low pressure was travelling from this, while here we have got a high pressure line and a low pressure line; separate line because the compressor kind of compressor used here will have two valves, inbuilt valves over here which are actually direction dependent valves.

So, high pressure gas comes over here, and we have in addition, one more valve in between the compressor and expander. If we call this as a expander, and this is compressor, we have got some valve here which will allow the high pressure gas to come out for some time, and then high pressure gas will come over here, and the displacer is housed here.

And suddenly after some time, the high pressure gas will stop because this valve will stop the high pressure gas to come out, and hit the low pressure valve will open, the gas here will get expanded producing low temperature, and again the displacer will move down, and the gas will be displaced back and it go to the low pressure, and the cycle will continue.

So, high pressure gas will come for some time, and the low pressure gas will go after some time. So, whatever is the compressor used here, we have got a relationship between the rotary valve or valve which is used here, some valve kind of mechanism and a displacer motion. This is very important. So, this schematics is Gifford McMahon cryocooler.

The required phase difference again has which was done over here between the compressor piston and a displacer. Now here, it will not be compressor piston and displacer, but between the valve mechanism which is used over here and the displacer. Displacer will move according to the valve mechanism when does high pressure gas come in, when does low pressure gas go out. So, required phase difference is maintained by relative motion between the valve mechanism and the displacer motion in case of a Gifford McMahon cryocooler.

The Stirling cryocooler work at a high frequency, because you can see here, the frequency of the piston will be same as that of the main phase may be 50 Hertz, may be hundred and 20 Hertz whatever, and a displacer has to move with the same frequency as that of the piston. Therefore, this is called as a high frequency machine.

The Stirling cooler therefore, work at high frequency, while the Gifford McMahon cooler; they do not work at high frequency. It will move at a frequency of this valve. At what frequency the valve opens, high pressure valve and the low pressure valve mechanism works, so, this is normally works between 1 to 5 Hertz. So, there is actually called as low frequency machines. They got different advantages and disadvantages also.

So, Stirling cryocooler work at high frequency, while G-M cryocooler works at low frequency.

(Refer Slide Time: 32:48)

The slide is titled "CRYOGENIC ENGINEERING" and "Regenerative Cryocoolers". It features a schematic diagram of a pulse tube cryocooler. The diagram shows a gas source at the top left with a downward arrow labeled  $\dot{W}_0$ . A tube leads to a regenerator (blue block) with a leftward arrow labeled  $\dot{Q}_0, T_0$ . The tube then goes to a pulse tube (green block) with a downward arrow labeled  $\dot{Q}_c, T_c$ . From the pulse tube, the tube goes to another regenerator (blue block) with a rightward arrow labeled  $\dot{Q}_h, T_h$ . The tube then goes to a gas source at the top right with an upward arrow labeled  $\dot{W}_0$ . The pulse tube is labeled "Pulse Tube Cryocooler".

- Pulse Tube Cryocooler works without having any mechanical displacer. Instead, gas works as a displacer.
- There is no need for a mechanical drive for the displacer.
- As a result, the magnitude of vibrations in the Pulse Tube Cryocooler is less as compared to Stirling and Gifford McMahon Cryocoolers.

NPTEL  
Prof. M D Atrey, Department of Mechanical Engineering, IIT Bombay

In addition to this Stirling and G-M, what we have is also pulse tube cryocooler. So, what you can see in pulse tube cryocooler is, there is no displacer and the expander here. There is no mechanical displacer over here, and therefore, we do not require a drive for this also. In earlier two case, is because the displacer is moving, we will require a drive mechanism for this displacer motion also.

So, pulse tube cryocooler works without having any mechanical displacer, instead gas works as a displacer. There only a tube with filled with gas, and all of them have got a regenerator over here. There is no need for a mechanical drive in this case, because there is no mechanical displacer, and therefore, one complete moving unit is you know got read of here. We have just got read of one moving part basically, which means this is more reliable system. There is no wear and tear. There is no need of a mechanical drive for this.

So, naturally, the vibration in this case are much less as compared to what they are for Stirling and G-M cooler s right, because there is a displacer, and there is no displacer in this case. As a result, the magnitude of vibration in pulse tube cryocooler is less as compared to Stirling and Gifford McMahon cryocoolers. Simple thing. We will go

through the details of all this cryocooler in the coming lectures, but I just wanted to highlight differences or different regenerative cryocoolers.

(Refer Slide Time: 34:00)

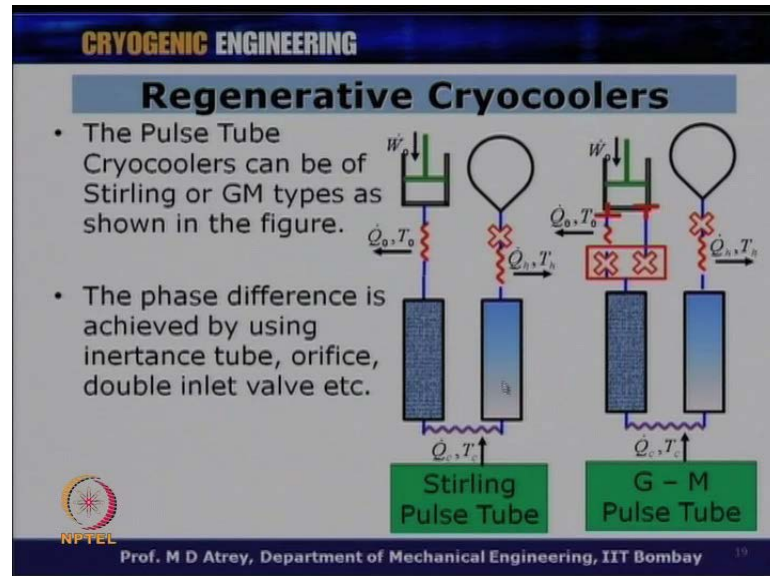

Now, this pulse tube Cryocooler can be with valve or without valve, which means; they can be of Stirling type pulse tube cooler; which is without valve, and also they could of G-M type pulse tube cooler; which means there is a valve elements between the compressor and expander. This is called as Stirling type pulse tube cooler. This is called as G-M type pulse tube cooler. As I said, this is the high frequency machine. This could be a low frequency machine.

So, the pulse tube cooler can be of Stirling type or a G-M type as shown in this figure. The phase difference is achieved using an inertance tube. What you can see is all these things, when you got a gas moving over here, one has to have some relationship between the gas and the piston motion, in order that the cooling effect gets produced, and therefore, there are different kind of phase shift mechanisms which are could be inertance tube or if it is double inlet valve, you may have heard of these things, and we will study this phase shift mechanism in detail in the further lectures.

But what you have to see here, because there is no mechanical driven displacer, you got a gas which is moving up, and in order that a particular phase difference gets maintained between this gas motion in the relation to the piston motion, we have got a phase shift mechanism which is actually introduced by are the inertance tube orifice or a double

inlet valve, and also you can see a reservoir on the top. These are nothing but all the devices which actually introduce this phase difference or nullifies this phase difference; we can see that in the later valve.

(Refer Slide Time: 35:23)

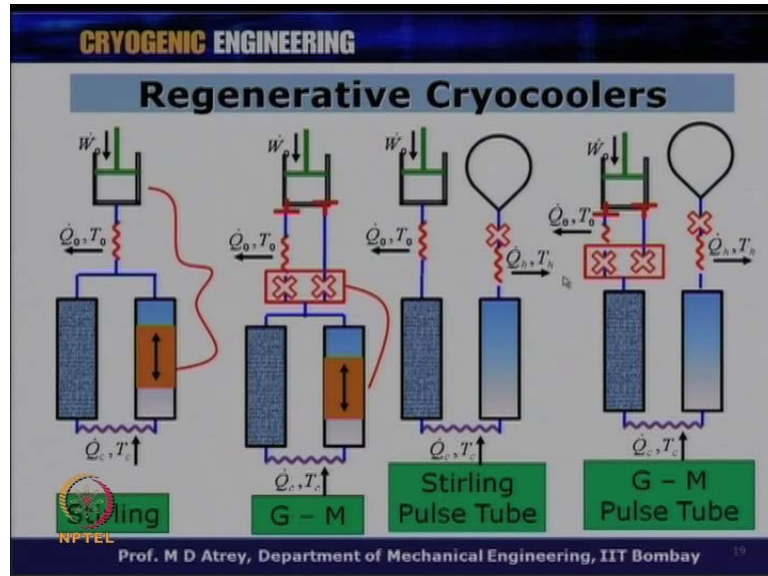

So, if I see all the four cryocoolers, we can see a Stirling cryocooler, a G-M cryocooler; the difference between, you can identify the difference because of this valve mechanism in between or having h p and l p line over here. Stirling type pulse tube cooler and a G-M type pulse tube cooler; the pulse tube cooler can be highlighted with the fact that there is no displacer shown over here. And a G-M can identify by the fact that there is a valve over here. In this case, valve over here. This is a very important things, and all this four cryocoolers are very important to understand how they work.

(Refer Slide Time: 35:54)

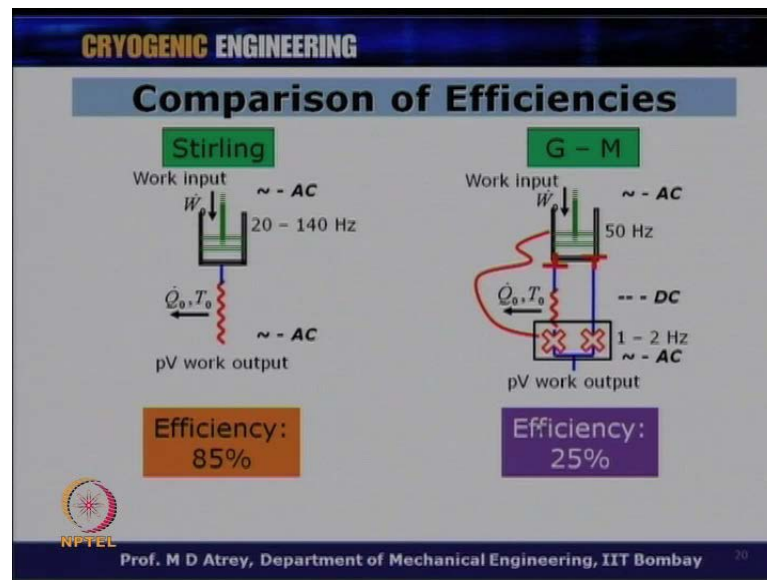

So, with this background, we can see now, what is the comparison of efficiencies of a Stirling Cryocooler and a G-M cryocooler. So, you can see a Stirling cryocooler has got AC power supply which is out from our mains, and what you get here also is oscillating pressures. So, essentially there is no conversion from AC to AC, but there is the conversion from AC to OC. So, what goes in is a oscillating motions over here which is 20 to 140 Hertz, and at a same frequency, the pressure will come out oscillating at the same pressure which is fed to the expander.

So, there is no conversion from AC to DC or DC to AC; whatever oscillating motion is here of the piston, the same oscillating motion of the pressure will go to the expander, and this AC to AC this conversion all right, could be about 85 percent, all right. This AC to AC basically; it is a power transmission from AC and what you get ultimately is a P-V pressure volume diagram. So, this conversion could be 85 percent over here, and therefore, Stirling coolers are supposed to be very efficient over here.

On the other hand, if you go to G-M cryocooler, your supply is main supply again and therefore, this is oscillating, but your got a valves in between, and therefore, what you get from here is AC to DC conversion. We get a HP line- high pressure line and low pressure line defined over here. So, actually we can call this is a conversion from AC to DC because of the valves, and assuming that the valve efficiencies are 50 percent normally, we got a power loss of 50 percent over here, and again what is fed to the



cryocooler is AC form, because what we have want is a pressure fluctuations at this point. So, again this DC is converted to AC; that means, oscillating pressures which are fed to the expander due to the existence of this valve mechanism, which is a specific characteristic of G-M cryocooler.

See if I give 100 watts at this point, efficiency of this valve assumed to be 50 percent, what I get is only 50 watts at this point, and again 50 percent efficiency at this point. So, what I get ultimately is only 25. And therefore, overall efficiency of G-M cooler is a much less as compared to what it is a Stirling Cryocooler, and why it is less, because of the presence of the valves. This presence of the valves actually brings about inefficiency in a system, and what is delivered as 100 watts input and what is delivered at the outlet is only 25 watts. So, G-M cooler is very inefficient in cycle. So, one has to feed lot of wattages over here, in order to get cooling effect at this point.

So, because the presence of valves, it is very important to understand that efficiency of G-M cooler is much less as compared to what it is for Stirling coolers.

(Refer Slide Time: 38:34)

**CRYOGENIC ENGINEERING**

### J - T Cryocooler

**Uses**

- Cooling IR sensors on missiles, surveillance cameras.
- Cooling semi conductor electronics.
- Cryosurgery.
- Liquefaction of natural gas.

**Recent Developments**

- Mixed refrigerants.
- Sorption compressor.

The diagram illustrates the J-T cryocooler cycle. It shows a gas being compressed (input work  $\dot{W}_c$ ), then expanding through a valve. The expansion process is shown with a color gradient bar representing temperature change. The gas then passes through a regenerator (represented by a rainbow-colored bar) and is further cooled. The final cooling stage is labeled with  $\dot{Q}_c, T_c$  and a minus sign, indicating heat rejection at a low temperature. The regenerator is also labeled with  $\dot{Q}_h, T_h$  and a plus sign, indicating heat rejection at a higher temperature. The NPTTEL logo is visible in the bottom left corner of the slide.

Now, let us go through each cryocooler and just see advantages and disadvantages of various cryocooler. So, a J-T Cryocooler is used for cooling infrared sensors on missiles, surveillance cameras. It can be used for cooling semiconductor electronics and also recently, it is being used for cryosurgery because the high pressure gas just goes in, it



gets expanded, produces cooling, and it can just go out to the atmosphere or it can be recompressed also.

So, there are various usages J-T Cryocoolers are normal used. Also it can be used for to liquefy natural gas. The recent developments in J-T Cryocoolers are, instead of using a single gas, we can use mixed refrigerant, and if I use mixed refrigerant, my pressure limits are coming down. So, it is a very recent phenomena, very recent developments happening in this field. And also, instead of moving compressor, one can use sorption compressor also. So, gas can be adsorbed, the gas can be dissolved. So, sorption compressor is a latest phenomenon people are looking at, as a result of which nothing will be moving in a J-T Cryocooler.

(Refer Slide Time: 39:36)

The slide is titled "CRYOGENIC ENGINEERING" and "J - T Cryocooler". It features a schematic diagram of a J-T cryocooler cycle. The diagram shows a gas flowing from a high-pressure reservoir through a valve (indicated by a red 'X') into a heat exchanger (represented by a red and blue gradient box). The gas then expands through a small orifice (indicated by a blue 'X') into a low-pressure chamber. A heat exchanger is also shown at the bottom, with a red and blue gradient box. The gas then flows back through the heat exchanger and the valve to the high-pressure reservoir. The diagram is labeled with  $\dot{Q}_o, T_o$  and  $\dot{Q}_c, T_c$  at the heat exchangers, and  $-T$  at the cold end. A small inset photo of Prof. M D Atrey is visible in the top right corner of the slide.

**Advantages**

- No cold moving parts.
- Steady flow operation, no vibration.
- Cold end can be miniaturized.

**Disadvantages**

- Relies on real gas behavior.
- Requires high pressures, in the order of 200 bar.
- Small orifice, susceptible to clogging.
- Low efficiency.

NPTCL  
Prof. M D Atrey, Department of Mechanical Engineering, IIT Bombay

So, these are different highlights of J-T Cryocooler, the advantages are nothing moving on the cold sides. So, no cold moving part. Steady flow operation, and therefore, no vibration. You have got a high pressure line and low pressure line. Nothing oscillating. No pressures are oscillating. There is no oscillating flow in this case, and therefore, no vibration. The cold end can be miniaturized.

So, lot of research is going on to miniaturize this end, can we have a micro heat exchanger for example, and this is lot of developments are happening on this, and this is a very good advantage of a J-T Cryocooler. And disadvantages are one has to depend on the inversion temperature. So, real gas behavior we cannot use an ideal gas, real gas

behavior has to worry. We have to worry about its inversion temperature. It requires high pressure of the order of 200 bar if I use a single gas, and therefore, the pressure requirements are very high in this case.

And because of the orifice or a capillary tube, sometimes it can get clogged. It can get blocked with the impurities and therefore, this is susceptible to clogging, and this is the very important thing that many a time, this has to be cleaned. Sometimes the blockage can happen if the water vapor comes with gas, it can get ice formed over here, and it can block the flow of the gas. This is a very important thing, and this is one of the disadvantages of a J-T cryocooler of course, the efficiency is also low in this case.

(Refer Slide Time: 40:49)

**CRYOGENIC ENGINEERING**

### Stirling Cryocooler

**Advantages**

- High efficiency.
- Small size and weight.
- High reliability, practically zero maintenance.

**Disadvantages**

- Dry or no lubrication.
- Vibration due to mechanical displacer.

The diagram shows a Stirling cryocooler cycle with a compressor at the top, a regenerator in the middle, and a displacer and power piston at the bottom. Heat input  $Q_c, T_c$  is shown at the bottom, and heat output  $Q_o, T_o$  is shown at the top. Work input  $\dot{W}_c$  is shown at the compressor. The NPTEL logo is at the bottom left, and the text 'Prof. M D Atrey, Department of Mechanical Engineering, IIT Bombay' is at the bottom right.

Now, if I see Stirling cryocoolers here, they are used very predominantly to cool the infrared sensors in satellite in space application. So, all the satellite experiments normally will be using Stirling type cryocoolers or Stirling coolers. It can be also be used to cool the high temperature superconductors, and also we have seen earlier that the Stirling cryocoolers; several Stirling cryocoolers working together can be used for nitrogen, air, hydrogen liquefaction .We have seen this in a liquefaction earlier.

So, Stirling cooler cryocoolers have been used for quite some time and their usages are have been very significant. The recent developments are linear compressors which is the dry compressor being used, which uses a flexure bearing. In this case, we have got a gas bearing also nowadays to you know smoothen flow of the gas between the compressor

and the displacer compressor piston. So, gas bearing effect also can be realized in Stirling cryocoolers.

We can do easily multistage to reach a lower and lower temperature, and that is where hydrogen can be liquefied. If I can go for a two stage unit to generate 20 Kelvin, this can be use for various end usage application.

So, advantages of Stirling cryocoolers is basically high efficiency, small size and a weight, it is a reliable operation practically zero maintenance, if possibly design correctly. Disadvantages are dry or low lubrications many times, vibration due to mechanical displacer. Now this is the moving part and therefore, you can have some vibration at this end because of which it cannot be used in some places where vibrations are not acceptable.

(Refer Slide Time: 42:16)

The slide is titled "CRYOGENIC ENGINEERING" and "G - M Cryocooler". It features a schematic diagram of a G-M cryocooler on the left, showing a displacer (top), a compressor piston (middle), and a regenerator (bottom) with two columns. Arrows indicate the flow of gas and heat. The top left shows work input  $W_c$  and heat rejection  $Q_o, T_o$ . The bottom right shows heat absorption  $Q_c, T_c$  and a magnet  $-M$ . To the right of the diagram, under "Uses", are listed: Cryopumps, MRI, NMR equipments, and Laboratory magnets. Under "Recent Developments", are listed: 4 K operation and Rare earth regenerator materials. A small video inset shows Prof. M D Atrey. The NPTEL logo and "Prof. M D Atrey, Department of Mechanical Engineering, IIT Bombay" are at the bottom.

The G-M cooler as we know, we have just seen the G-M cooler which has got a valve mechanism over here, it is widely use in cryopumps. It is a very important usage of G-M cryocoolers; it is being widely use in cryopumps. It is also used in MRI machines and NMR equipments. This is very important thing about G-M coolers. On every MRI machine, if G-M cooler being used for shield cooling, where NMR also it used for cold purposes. So, G-M cooler is being used in various applications for cooling of super conducting magnets.

Recent Developments; one can go for 4 Kelvin coolers, use of rare earth regenerator materials in the regenerator for second stage.

(Refer Slide Time: 42:55)

**CRYOGENIC ENGINEERING**

### G - M Cryocooler

**Advantages**

- It can reach 4 K in two stages.
- Proven reliability.
- It is a low frequency machine.

**Disadvantages**

- High vibration.
- Less efficiency.
- Noisy operation.
- Requirement of sealing at low temperature.

The diagram shows a G-M cryocooler with a displacer (green) and a piston (orange) in a regenerator (blue). It includes labels for work input  $W$ , heat rejection  $Q_0, T_0$ , and heat absorption  $Q_c, T_c$ . The NPTEL logo and Prof. M D Atrey, Department of Mechanical Engineering, IIT Bombay are also present.

And advantages are it can reach 4 Kelvin in two stages. It has got proven reliability for quite sometimes. It is a low frequency machine as you know, and therefore, the vibrations are at low frequency here.

The disadvantages are; however, it has got a vibrations which is not acceptable sometimes at various applications, less efficiency as we pointed out, every G-M cooler is basically of less efficiency because of the presence of valves, and of course, it is a noisy. One can know the displacer moving up and down all the time because it uses sealing also at this point which is also a disadvantages in a G-M cryocoolers.

Yeah here is a disadvantage; its requirement sealing at low temperature and as you know, sealing at low temperature is not a very easy task, and this sealing is a rubbing basically at this point, which is also very disadvantageous.

(Refer Slide Time: 43:40)

**CRYOGENIC ENGINEERING**

### Pulse Tube Cryocooler

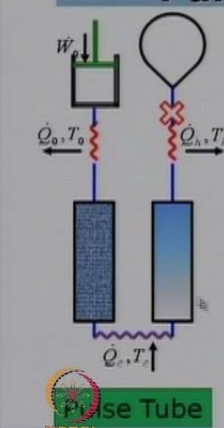

**Uses**

- Cooling of infrared sensors.
- Space applications.
- Re-condensing of **LHe** and **LN<sub>2</sub>**.

**Recent Developments**

- Reached below 4 K.
- Miniaturization.

**Pulse Tube**

NPTEL

Prof. M D Atrey, Department of Mechanical Engineering, IIT Bombay 27

Pulse tube cooler has a biggest advantages of having no displacer and therefore, no mechanical drive, and therefore, no vibrations or less vibration in this case. It can also be used for cooling infrared sensors. It can be use in space application. It is just being used now you know, the usage has just started importantly; however, it can be used to re-condense liquid helium and liquid nitrogen. It is a very important because the vibrations in this case will be very minimum, and therefore, it can whatever helium get boiled off, it can get condensed, whatever nitrogen is boiled off, it can get condensed, and that much of cooling effect can be offered by pulse tube cryocooler.

The recent development pulse tube cryocoolers can easily reach below 4 Kelvin. It can be miniaturized. So, you can have a high frequency Stirling type machines which can be used for cooling, producing cold.

(Refer Slide Time: 44:25)

**CRYOGENIC ENGINEERING**

### Pulse Tube Cryocooler

**Advantages**

- No cold moving parts.
- No sealing requirement at low temperature.
- Less vibration at the cold end.

**Disadvantages**

- No reliability data.
- Orientation effects.

**Pulse Tube**

NPTEL

Prof. M D Atrey, Department of Mechanical Engineering, IIT Bombay

The advantages are: no cold moving parts as you know here, nothing is moving, no sealing requirement because there is no displacer here, there is no sealing requirement at low temperature which is very much required in G-M coolers, less vibration at the cold end because there is no mechanical displacer at this point.

The disadvantages are: there is no much reliability data right now available because pulse tube coolers have been recently use after two thousand in space application for example. So, we do not have a time data over period of time to show its reliability as compared to what we have with Stirling coolers.

Stirling coolers has a orientation effects. It is a one of the most disadvantageous thing about the Stirling type pulse tube cooler or pulse tube cooler is; this being a gas phenomenon, there is no displacer. It has got its inclination effect if its used with gravity against gravity. It does show some listening of cooling effect with orientation and this is the parameter. This is the design aspect which is being considered which is under research at the moment.

(Refer Slide Time: 45:26)

The slide is titled "CRYOGENIC ENGINEERING" in a blue header. Below it, the word "Applications" is written in a large, bold, black font. The main content consists of a bulleted list of three application areas. To the right of the text is a small inset photograph of a man in a suit. At the bottom left is the NPTEL logo, and at the bottom center is the text "Prof. M D Atrey, Department of Mechanical Engineering, IIT Bombay".

- Cryocoolers are used in the following areas.
- **Space:** Military – night vision IR cameras, IR detector cooling in space and satellite.
- **Gas Industry:** Gas cooling, liquefaction, storage, cryopumps.
- **Medicine:** Cryogenic catheter and cryosurgery.

NPTEL  
Prof. M D Atrey, Department of Mechanical Engineering, IIT Bombay

Having seen all this different cryocoolers, let us just see the overall applications of various cryocoolers. So, cryocoolers are using following areas. I have just shown in space, military, night vision camera, the infrared cameras, and infrared detector cooling in space and satellite; which is the very important aspect of cryocooling in space.

The gas industry use cryocooler for gas cooling, liquefaction, storage and cryopumps. It is a very important usage of cryocoolers. Similarly in medicine, cryogenic catheter cryosurgery; whenever at low temperature you want to do surgery, cryocoolers can be used .



(Refer Slide Time: 46:05)

The slide is titled "CRYOGENIC ENGINEERING" in a blue header. Below it, the word "Applications" is written in a large, bold, black font. The main content consists of a bulleted list of applications. The first bullet point states: "Continuing further, Cryocoolers are used in the following areas." The second bullet point is "Superconductivity: MagLev trains, Superconducting transformer, motor and generator." The third bullet point is "Energy sector: SMES, CERN." The fourth bullet point is "Cooling of MRI, NMR and SC Magnets." To the right of the text is a small inset photograph of a man in a suit. At the bottom left of the slide is the NPTEL logo, and at the bottom center is the text "Prof. M D Atrey, Department of Mechanical Engineering, IIT Bombay". A small number "30" is visible in the bottom right corner of the slide.

There also use in superconductivity. So, we can have a magnetic levitation train, it will use cryocoolers. Superconductivity and transformer; it will use, then all aspects of research being carried out, they will all use cryocoolers to give cold all the time. They will use cryogenes also and they may use cryocoolers also.

So, trains, superconducting transformer, motors and generator will use cryocoolers for its applications. In energy sector also, at SMES where Superconducting Magnetic Energy Storage devices, you can have energy also have CERN large hydrogen collider usage. Cryocoolers are being used informs of cryopumps or also has cryocoolers in this sector.

Of course, cooling of MRI, NMR and superconducting magnets; cryocoolers are predominantly use right now. In fact, cryocoolers being used in MRI is one of the most important boost for the cryocooler industry, because this is the most commercial application right now, which has really you know initiated or attracted cryocoolers to be produced in large number and because of which the cryocooler costs have come down.

(Refer Slide Time: 47:19)

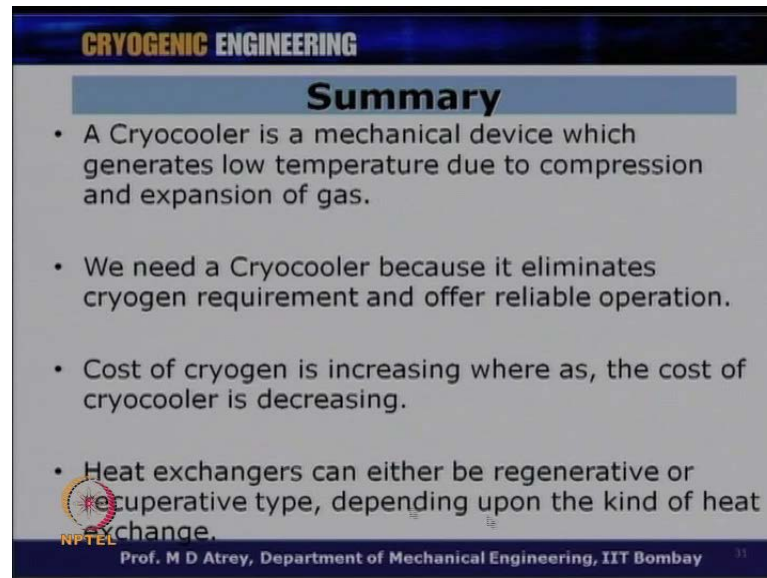

**CRYOGENIC ENGINEERING**

### Summary

- A Cryocooler is a mechanical device which generates low temperature due to compression and expansion of gas.
- We need a Cryocooler because it eliminates cryogen requirement and offer reliable operation.
- Cost of cryogen is increasing where as, the cost of cryocooler is decreasing.
- Heat exchangers can either be regenerative or recuperative type, depending upon the kind of heat exchange.

NPTEL  
Prof. M D Atrey, Department of Mechanical Engineering, IIT Bombay 31

Lastly, giving the summary, a cryocooler is a mechanical device which generates low temperature due to compression and expansion of gas. We need cryocoolers because it eliminates cryogen requirements, and offer reliable operation. Cost of cryogen is increasing whereas, the cost of cryocooler is decreasing. Heat exchangers can either be regenerative or recuperative type; depending upon the kind of heat exchange.

(Refer Slide Time: 47:40)

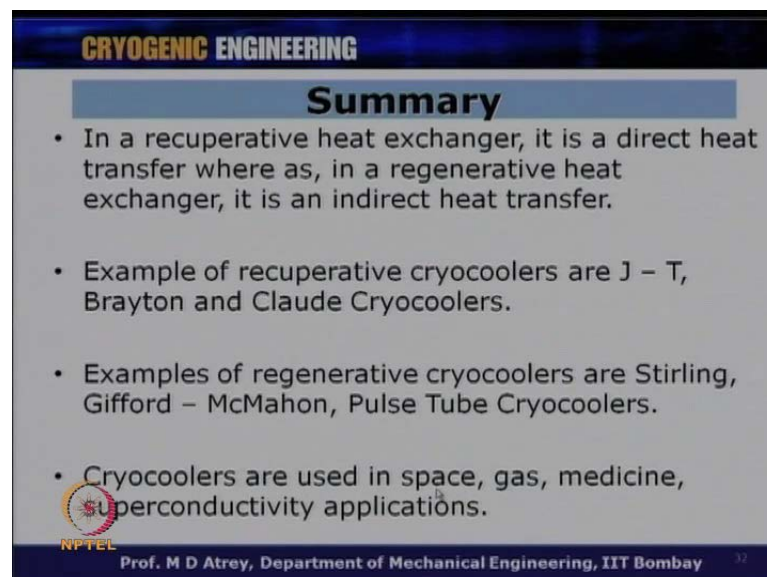

**CRYOGENIC ENGINEERING**

### Summary

- In a recuperative heat exchanger, it is a direct heat transfer where as, in a regenerative heat exchanger, it is an indirect heat transfer.
- Example of recuperative cryocoolers are J – T, Brayton and Claude Cryocoolers.
- Examples of regenerative cryocoolers are Stirling, Gifford – McMahon, Pulse Tube Cryocoolers.
- Cryocoolers are used in space, gas, medicine, superconductivity applications.

NPTEL  
Prof. M D Atrey, Department of Mechanical Engineering, IIT Bombay 32

In a recuperative heat exchanger, direct heat transfer, whereas, in regenerative heat exchanger, it is indirect heat transfer.

The example of recuperative cryocoolers are J-T, Brayton and Claude cryocoolers. Example of regenerative cryocoolers are Stirling, Gifford McMahon, pulse tube cryocoolers which we just saw. The cryocoolers are used in various application; in space, gas, medicine, superconductivity applications.

(Refer Slide Time: 48:03)

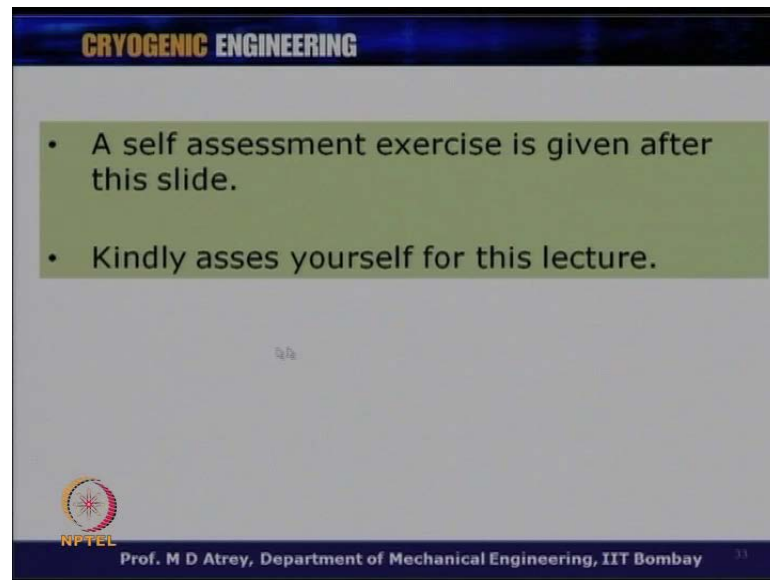

**CRYOGENIC ENGINEERING**

- A self assessment exercise is given after this slide.
- Kindly asses yourself for this lecture.

NPTEL  
Prof. M D Atrey, Department of Mechanical Engineering, IIT Bombay

Finally, we have got some self-assessment exercises for you at the end, and please go through. Kindly asses yourself for the lecture, and also we are going to answers for this. So, please go through these questions, assess yourself honestly, and see if your answers match with the answers given at the end. Thank you very much.