

Pulsewidth Modulation for Power Electronic Converters
Prof. G. Narayanan
Department of Electrical Engineering
Indian Institute of Science, Bangalore

Lecture - 15
Sine-triangle pulsewidth modulation

Welcome back to this video course on Pulsewidth Modulation for Power Electronic Converters. So, we have looked through quite a few modules in several lectures on this and now this is going to be our 15th lecture. Then we would be focusing on sine triangle pulse width modulation first if you recollect we started off with various power converter technologies; a various power converter topologies.

We started off with DC and then we looked at voltage source inverter and current source inverter and everything around that multi-level inverters and so on so forth. Then we looked at certain basics of you know there are applications of voltage source inverters in terms of motor drives and things like that; then we looked at Fourier series and some fundamentals regarding pulse width modulation then our focus was on low switching frequency PWM.

Where the switching frequency of the inverter is not much higher compared to that of that today we are going to focus on the sine triangle pulsewidth where our focus is I mean the frequency is going to be more than whatever you have on with high frequency PWM method, the switching frequency is much higher than the fundamental frequency. So, we say sine and triangle because most of you may already be familiar with that because it is one of the most popular methods the modulating signal would be sine and then the carrier signal would be triangle. And therefore, you have this as sine triangle and pulsewidth modulation.

(Refer Slide Time: 01:42)

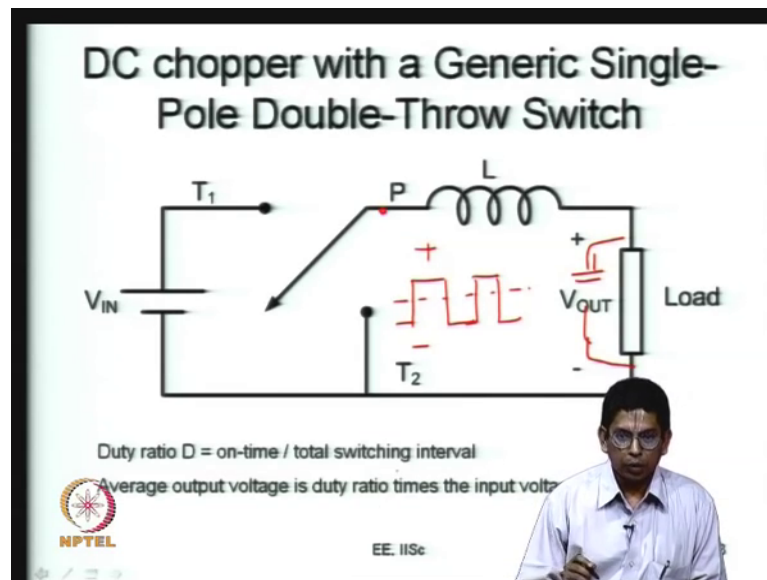

So, to start with this let us go back to our generic DC chopper, I mean with a generic single pole double throw switch why you want have it and what you want to do is now. So, here we have a single pole double throw solution.

So, if you recollect this is one of the first converters we did now. So, what we wanted to essentially here is we have this voltage between these 2 we apply a pulsed waveform like this by turning this on and off you are applying a pulse waveform like this why did we you do this so that we can achieve a lower value of average.

So, in effect what we are doing is we are controlling the average voltage at this point T may be measured with respect to T 2 or the DC bus negative terminal this is what we have been doing and we use an L filter here to reduce your to L filter to smoothen the current and in addition to that you can also put a capacitance here if you wish we are also put a capacitance here particularly in case of power supply applications you need a capacitance. So, when you come to the low I mean you get a better voltage ripple also. Now, we are just going to move towards a single pole double throw inverter.

(Refer Slide Time: 03:05)

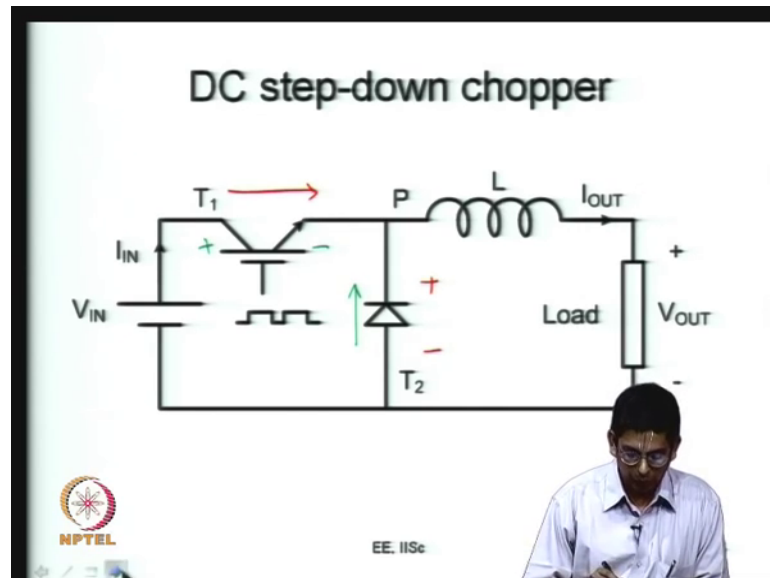

This we realized using a unidirectional or single quadrant switches.

Where you have a transistor and you have a diode like this and this transistor conducts current in this direction with the diode blocking with this polarity. And similarly, if you consider the other state, let us say you consider the other state then current may be flowing through the diode like this and the voltage blocked by the transistor has this kind of polarity. So, this is you realize them using single quadrant switches here.

(Refer Slide Time: 03:41)

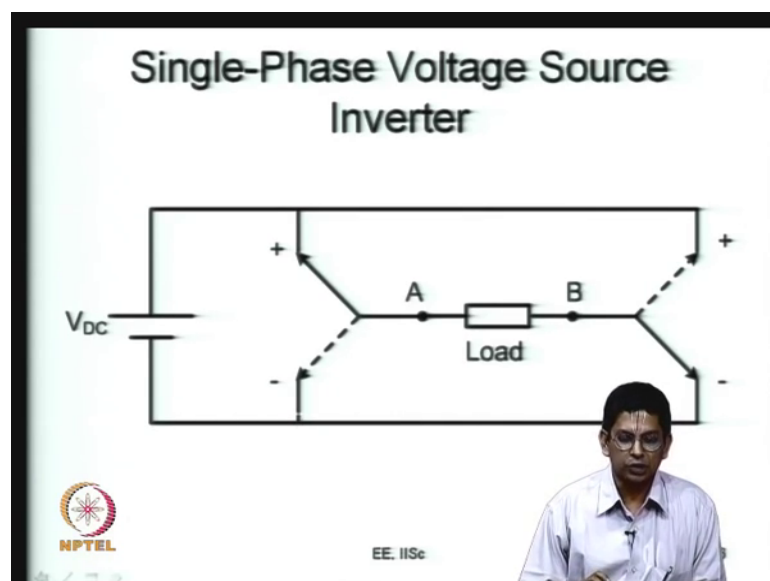

When you go to a single phase inverter, it will be a little different as we see here, it is once again going to be a single pole double throw switch and every leg is really a single pole double throw switch here. Now the load is presumed to be inductive. So, one of the load terminals is connected to the pole and then there are 2 throws and what you have is the voltage source connected across that throw, right then you have this.

(Refer Slide Time: 04:03)

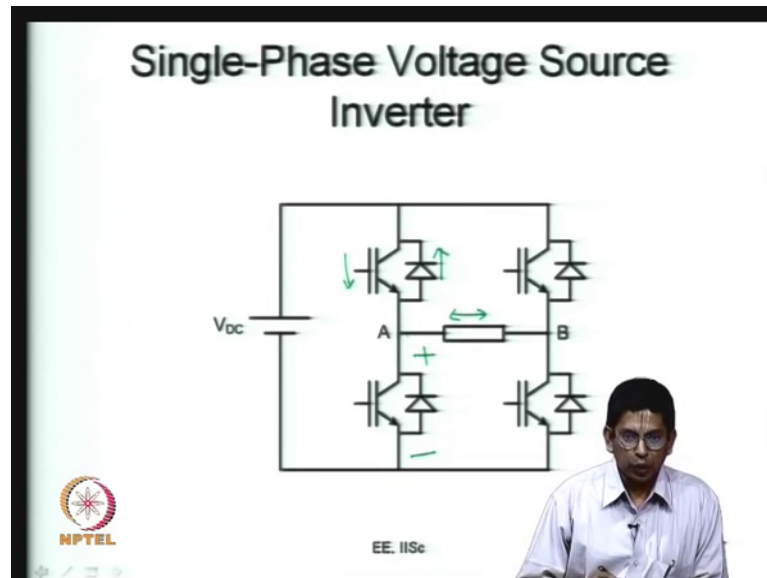

The next one you put this here how do you realize this using two such switches transistor with anti-parallel diodes now because now in your load the current can be bidirectional here the current can be bidirectional. So, if the current is bidirectional then these switches have to be bidirectional that is why you have a transistor which can conduct in this direction and you have a diode that can be that can really conduct in the other direction, but the voltage blocking capability. Let us say the top is conducting the bottom device is now blocking of potential and that potential is you know the character of the bottom transistor is positive with respect to emitter as indicated above. So, the voltage blocking capability is only unidirectional, but the current carrying capability is bidirectional.

Hence, you have this kind of a realization in a voltage source inverter. So, now, we are going to look at I mean once again the average value here before that we go back to what we do in the case of a single phase I mean in a DC chopper now. So, here what we try and do is we have voltage pulses like this right.

(Refer Slide Time: 05:16)

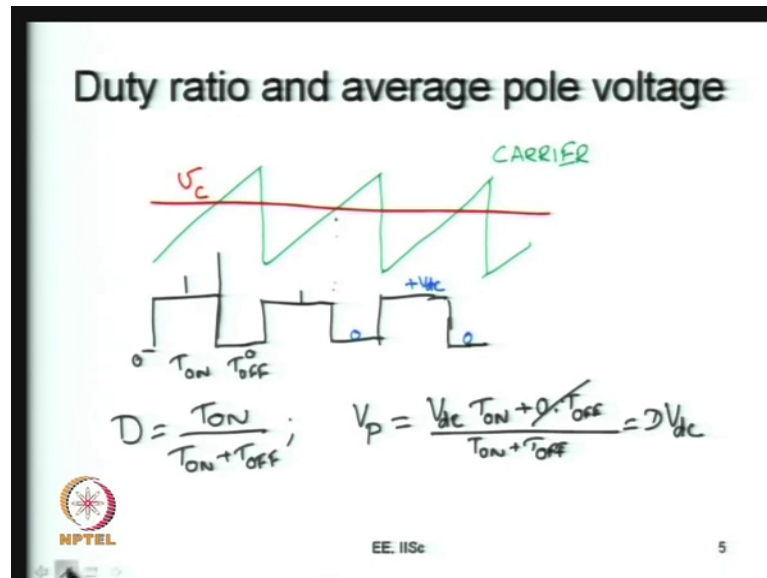

You have voltage pulses like this what you have. Now how do you create this? One way to do that is or the most common way to do that is you have carrier running like this, what is called as a ramp signal or a shorthud signal you can handle it running like this this is here what is called as here carrier now on this carrier you can have another signal what is called as a control signal. So, this control signals I am marking with red ink and I am calling it as v control.

Now, you can compare these 2 signals you can compare these 2 signals let me change the colour of ink to something else. So, whenever the carrier is greater than the ramp you can say that it is high you can say it is high again this is low again it goes high again it goes on like that. So, this is what is really your gating signal this is the gating signal that you apply to the transistor in a chopper now you can call this time as T ON you can call this time as T OFF, T ON is the time when the transistor is on and T OFF is the time when the transistor is off and the diode is conducting. So, you have the duty ratio defined T ON upon T ON plus this duty ratio itself is a measure of your average output voltage or your pole voltage we the pole voltage here is now your output voltage here whatever you get here the average voltage here is same as the average voltage here.

On this side of the inductor because the inductors on average voltage is 0 at steady state; so you are looking at the average pole voltage. So, this is essentially what you have is the average pole voltage let me call this as VP, let me call this VP meaning what is called as

the average pole voltage what I am trying to say is the pole voltage itself is the voltage at that pole itself is going up and down like this the same way as the gating signal does in the case of gating signal you will just call it as logic 0 and this is logic 1, this is 0 and 1; the same thing what you can say is if you look at the pole voltage this will be equal to plus V DC are the input voltage here are this will be 0. So, this will be plus V DC and 0 will go on like that now.

So, the average pole voltage is nothing, but you have apply V DC for T ON seconds and you apply 0 for T OFF seconds then you divide it by T ON plus T OFF. So, V_P is the pole voltage now you have the capital V_P is now the average pole voltage the instantaneous pole voltage at some time is plus V DC for duration T ON and it is equal to 0 for certain duration T OFF and now if you average it out over the entire cycle it is $V_{DC} T_{ON} + 0 \times T_{OFF}$ is equal to $T_{ON} + T_{OFF}$ which is equal to V_P . So, what do you get here this is what you call as the average pole voltage now and what is this average pole voltage you can simply see that this is a 0 term. So, it is simply a like your duty ratio times V DC. So, the average pole voltage is simply duty ratio times V DC for you.

So, this is how we define average pole voltage and this is mean what we have defined duty ratio here and how pole voltage average pole voltage is you know related to the average duty ratio here. So, you control the average pole voltage by controlling this duty ratio which is again controlled by controlling this VC waveform that you see here if I push the VC up what happens is; if it goes up a little the duty ratio will increase if this VC is reduced a little then the duty ratio will come down this is what happens now. So, this is how you do in a chopper in a chopper also you have a single pole double throw switch in a single phase inverter see you have a single pole double throw switch now the only difference is this is a bipolar voltage what we are going to do here is.

(Refer Slide Time: 09:59)

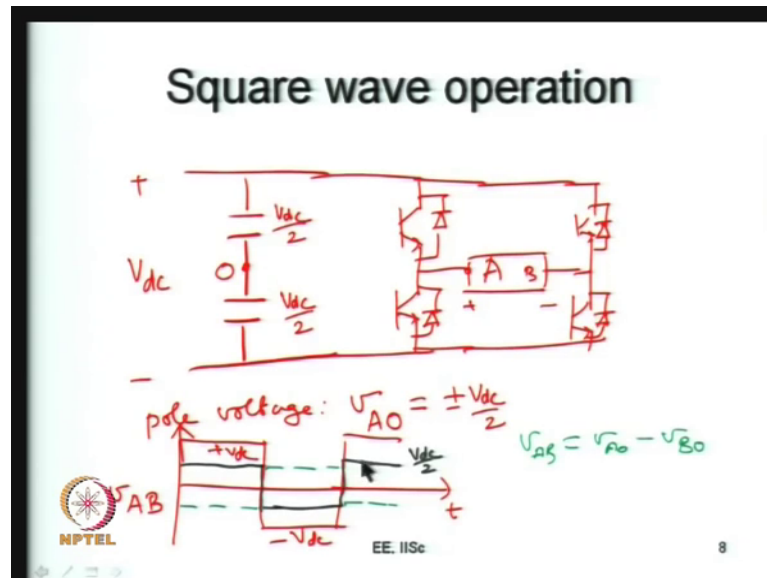

We are going to look at this potential with respect to the midpoint here there are some V DCs what I have indicated here we would say that let us say this is the DC voltage and this is the I am sorry. So, this is the DC bus midpoint O there is an entire DC bus voltage here there is a DC bus midpoint O. So, you have V DC by 2 potential here and another V DC by 2 potential here now I am going to draw just one leg here which is basically you have a transistor you have another transistor and you go about doing it like this now is a . So, now, you have a with respect to midpoint O.

So, this is what we would call as the pole voltage now pole voltage is this voltage at a measured with respect to O and at any instant it can take the values of plus or minus V DC by 2 have you not shown they like B you the similarly you can have the leg B also a simplest way to control this inverter is in the square wave fashion what you do is you can switch these top 2 devices you have the load coming here and there is the other terminal B and you have the other 2 transistors here the other 2 transistors here. So, these are the terminals A and B.

So, you can make sure that you have a kind of a square wave coming up a across here now. So, you can look at that V AB as a waveform like this, this can be your V AB this is your voltage V AB this is with respect to time T and this is plus V DC and this is minus V DC this is the if you look at the potentials you know v ab if you want to see with a with respect to O and B with respect to let me just change the color of ink here. So, this

would be V_{AO} ; hope this would be a V_{AO} where this is equal to V_{DC} by 2 and this is minus V_{DC} by 2 and how about your V_{BO} ; V_{BO} can be a let me just use another colour ink.

So, this would be your V_{BO} and now V_{AO} minus V_{BO} V_{AB} is V_{AO} minus V_{BO} . So, what you are doing is you are just switching these 2 inverters these 2 legs in a square wave fashion. So, A is switched A is switched from the negative to the positive to the positive here the top device is switched here the bottom device is switched on here the top device is switched here and so on. And excuse me it goes on like that for the B phase the opposite is done the bottom device is on and the top device is on the bottom device is on the top device is on. So, in effect what you would see is sometimes you will see this excuse me and this on then during other the interval other half the interval you will find these 2 on.

So, this is square wave operation and your effective voltage is something like this. So, it is this is your fixed load voltage. And now this load voltage has a sinusoidal component and that sinusoidal component will have an amplitude equal to $4 V_{DC}$ upon π as we have already seen now. So, this is what you can and you cannot control the fundamental voltage that is going to be the main problem here. So, this is the simplest way to produce AC out of DC and inverter supposed to just do that produce AC out of DC. So, you have to given to DC and you are able to produce the AC how is that just through square wave how do you do this this is just not, but here you cannot control the fundamental voltage when the DC voltage is fixed now.

(Refer Slide Time: 14:41)

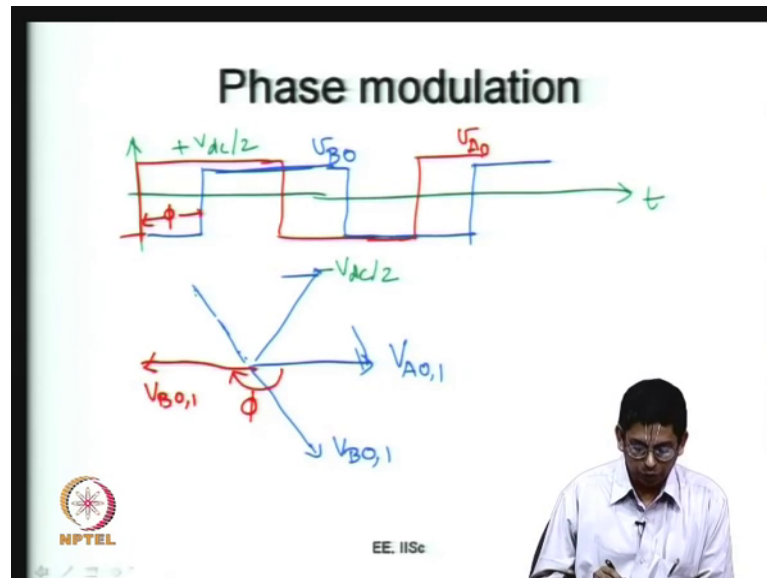

So, let us see how it can be done. So, one simple idea is what is; what I would call as phase modulation.

Now, let us say you have your time axis drawn here correct now let me say I let me use a colour ink, let me say this is my V AO this is my V AO. So, let me extract the time axis for the; this is the time axis and we have a V AO this is equal to plus V DC by 2 this is equal to minus V DC by two. So, here the top is on and in minus V DC by 2 meaning the bottom is on now in the regular square wave operation what you had was V AO and V BO at just out of phase; instead of that what I can do is I can sketch the V BO with some other phase difference now let me say I am sketching here like this, this is my V BO. So, what happens now V AO as well as V BO are identical waveforms both are square waves except that their phases are shifted by ninety degrees.

So, if we you can look at the fundamental components and you can do a harmonic analysis of the 2 now this is your V AO has a fundamental component. So, I will call this as V AO comma one this is the fundamental component of V AO expressed as a phasor now I can have V BO which may be lagging by certain angle, this is V BO one that is the fundamental component of B extras as a phasor now what I have is V AO minus V BO. So, this is minus V BO and I can do the sum of these 2 I can do a phasor addition of this, this would be my V AO minus V BO, let me go to a different situation this is my V AO

and I would apply my V_{BO} to be negative this is my V_{BO1} , this is exactly the square wave operation.

This is when you get the highest amount of fundamental voltage here what I am trying to see is says you can modify this phase angle what I call as ϕ and then you can get several values of several amplitudes of fundamental voltage here if V_{AO} and V_{BO} are totally out of phase then you get the maximum fundamental voltage if V_{AOR} ; V_{BOR} in phase, then you get 0. So, it is possible for you to vary the phase between V_{AO} or V_{BO} it is still the individual legs are operating like square wave, but they are not out of phase with one another they are different by some phase angle which we may call has some angle ϕ here this is what I would like to say. So, if you do this you can do this control now what is good about this control again you are switching only one cycle that is all.

So, the devices do not suffer much of losses you see that every time you switch on and off of loss here. So, that in case of square wave operation the device loss is very low, it is probably the lowest theoretically we will just switching once one cycle in one line cycle. So, you are able to vary this in do here now, but nevertheless we harmonic distortion is going to be fairly high. So, you can control the fundamental voltage here with the legs still switching at only with only one cycle in one fundamental cycle, but the harmonic content is going to be still high hence the reason we would go for pulsewidth modulation which we have been seeing for various cases.

(Refer Slide Time: 18:54)

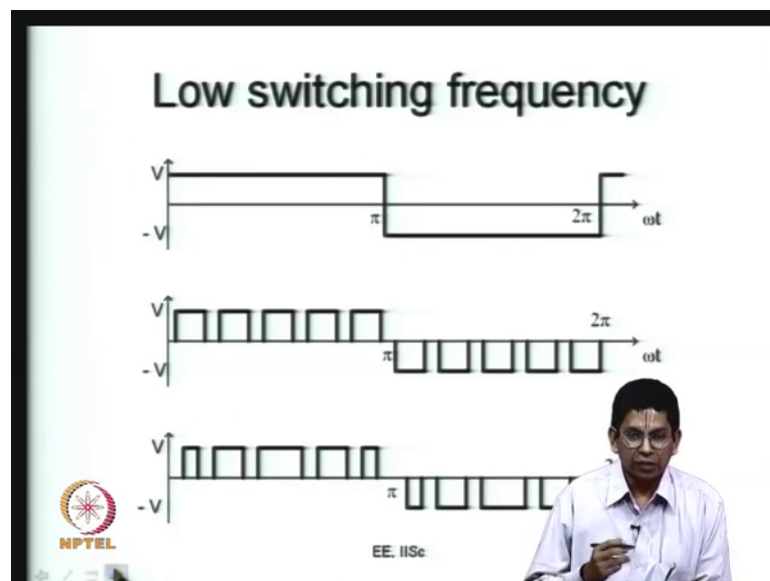

And now I would like to emphasize on this is low frequency and high frequency now.

What I can say is now if you take the square wave operation this is how your load voltage is going to be and now let me just draw in the case of a single phase inverter this will be equal to plus V_{DC} and this will be equal to minus V_{DC} if you operated in a square wave mode as I mentioned before you cannot control the fundamental I mean fundamental voltage it will be $\frac{4}{\pi} V_{DC}$ here and the harmonics are whatever they are that is $\frac{4}{n\pi} V_{DC}$ as you know through Fourier series now. So, you are going for modulation like shown here, you see here instead of a single pulse you have several pulses applied here they have certain widths and if this width is very small. Now in this case there are 5 pulses if all these 5 pulses have very low width then the corresponding fundamental voltage is very low if all these 5 pulses have long widths I mean our broad you know then it almost becomes like a square wave as in the earlier case. So, it has high fundamental voltage now.

So, by varying these widths of these individual pulses you vary that. So, this is some idea that we use and again these widths are uniform here and these which themselves are varied in a sinusoidal fashion here this makes sure that you get your desired fundamental voltage within certain limits and the harmonics are fairly low this is how you do this stuff these are some illustrations are low switching frequency PWM I have indicated only about 5 pulses here and 5 pulses here, similarly 5 pulses here and 5 pulses here sometime it can be 3, 5, 7 or sums low number like this, but this can be as high as you know 50, 60, several tens of them and sometimes a few hundreds of pulses also you might see.

That is basically whenever the inverter switching at a high frequency when the switching frequency of the inverter is much higher than the fundamental frequency more than 20 times or its 30 times 50 times the switching frequency is several tens of times of the fundamental frequency then you can call that as high switching frequency as supposed to that here these are all low switching frequency cases. Now we looked at the low frequency case for particularly for the three-phase inverter for certain amount of time when we dealt with selective harmonic elimination and things like that.

(Refer Slide Time: 21:15)

The slide contains the following handwritten text and equations:

High switching frequency –
Average pole voltage

$$v_{AO} = \pm \frac{V_{DC}}{2}$$
$$V_{AO} = \frac{1}{T_s} \int_0^{T_s} v_{AO} dt \quad T_s = \text{sub-cycle} \quad T_s \ll T$$
$$V_{AO} = \frac{+V_{DC} T_{ON} - V_{DC} T_{OFF}}{T_{ON} + T_{OFF}} ; D = \frac{T_{ON}}{T_{ON} + T_{OFF}}$$
$$= \frac{V_{DC} \cdot D - V_{DC} (1-D)}{2} = \frac{V_{DC} (2D-1)}{2}$$

NPTEL logo is visible in the bottom left corner of the slide.

Now, we are looking at high frequency switching frequency now we are considering a case where the inverter can switch at fairly high frequency that is the power levels are not very high.

So, the inverters I mean the devices you use may be IGBT is the MOSFETs that IGBT is can you know switch up to about 20 kilohertz or so. It has common to IGBT based inverters of frequencies 5 kilo hertz 10 kilos or 15 kilo hertz and at a fundamental frequency of 50 hertz even 5 kilo hertz switching frequency it gives a ratio of 100 between the switching frequency and the model modulation frequency. So, that is fairly high if you go for a MOSFET inverter many times, they switch at several tens of kilohertz like move on the ultrasonic frequencies 20 kilohertz is or the frequency up to which your ears can hear beyond that is beyond the audible range. So, it is called ultrasonic range most the many a times MOSFET inverters operate at ultrasonic frequencies which are very high. So, in such cases the frequencies are really really high.

Whenever the frequency is some 20 times more than the fundamental or. So, you can probably call it as high switching frequency and you can use the idea of average pole voltage what do we mean by this an average pole voltage this pole voltage as such is an instantaneous quantity it varies with time it is, but it say takes only select values it is plus V DC by 2 sometime or it is minus V DC by 2 sometime let me just write it down. So, if I say V AO as such is either plus V DC by 2 or it is minus V DC by 2 what I can do is I

can define some capital V_{AO} as average pole voltage which is I take this V_{AO} instantaneous V_{AO} integrated with respect to time oh what interval all the way from 0 to T_s and I divided by T_s this is what you get. So, this is your average pole voltage. So, now, this is V_P average is that clear. Now, this is your average pole voltage how; how can we use this idea of average pole voltage what is really inherent here now do you use this then the switching cycle time.

What I say is T_s or this is sometimes called sub cycle or you know half carrier cycle in as we go a little further this T_s is much much smaller than your period T your line cycle where this T corresponds to your line cycle this kind of thing is your average pole voltage. Now once again if you take an inverter if you look at it can either the V_{AO} or V_{BO} as we said before. So, what we can say is this V_{AO} is sometimes equal to plus V_{DC} by 2 and sometimes it is equal to minus V_{DC} by 2 and let us say it is plus V_{DC} by 2 when it is plus V_{DC} by 2 it is plus V_{DC} by 2 whenever the top device is on let us call that time as T_{ON} and when it is minus V_{DC} by 2 when the bottom device is on let us call that time as T_{OFF} .

So, this is this whole thing divided by T_{ON} plus T_{OFF} is your average pole voltage, let us check if you are doing it correctly. So, the instantaneous pole voltage can be either plus V_{DC} by 2 or minus V_{DC} by 2 it is plus V_{DC} by 2 for certain amount of time which we call as T_{ON} and it is minus V_{DC} by 2 for certain time that we call as T_{OFF} now then this is the average pole voltage that you really get now. So, you can see that once again you come to some expression here if you still define your duty ratio the same way as we define before duty ratio being T_{ON} upon T_{ON} plus T_{OFF} then you have your average pole voltage as this is V_{DC} by 2 multiplied by your duty ratio D and this is minus V_{DC} by 2 multiplied by one minus plus T_{ON} plus T_{OFF} add to your overall switching cycle time T_s and.

Therefore you call this is one minus V_{DC} V_{DC} by 2 times one minus t . So, you see that once again you are able to relate D 2. So, if I if I simplify this I would take V_{DC} by 2 then there is D minus of D , then you have $2D$ minus 1. So, you see that there is a relationship simpler relationship between the duty ratio D and V_{AO} . So, the average pole voltage once again you can define it in terms of the duty ratio D how do we normally do that.

(Refer Slide Time: 26:12)

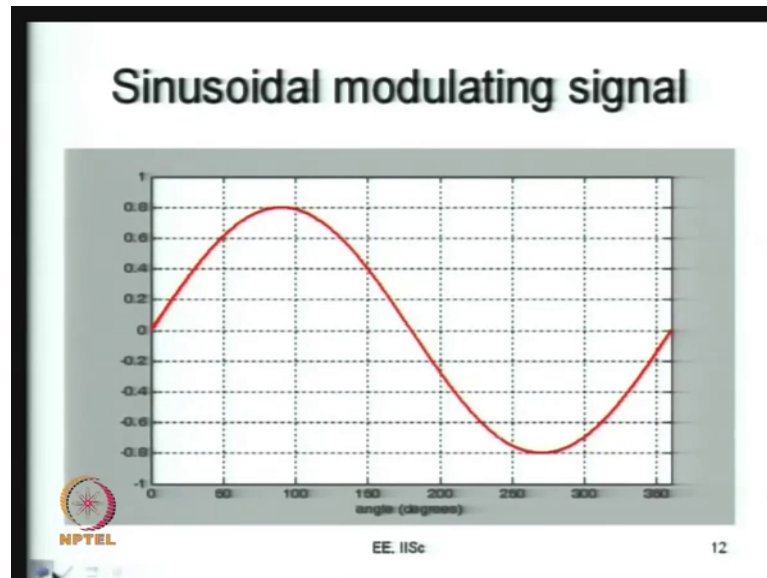

This V_{AO} in the case of a single I mean in the case of a chopper is a fixed DC quantity is a fixed DC quantity the pole voltage, but now this pole voltage is a variable quantity, it varies how does it vary; it varies in a sinusoidal fashion as illustrated here. So, this V_{AO} varies in a sinusoidal fashion here this is the average pole voltage, we want the average pole voltage to vary in a sinusoidal fashion as shown here.

(Refer Slide Time: 26:55)

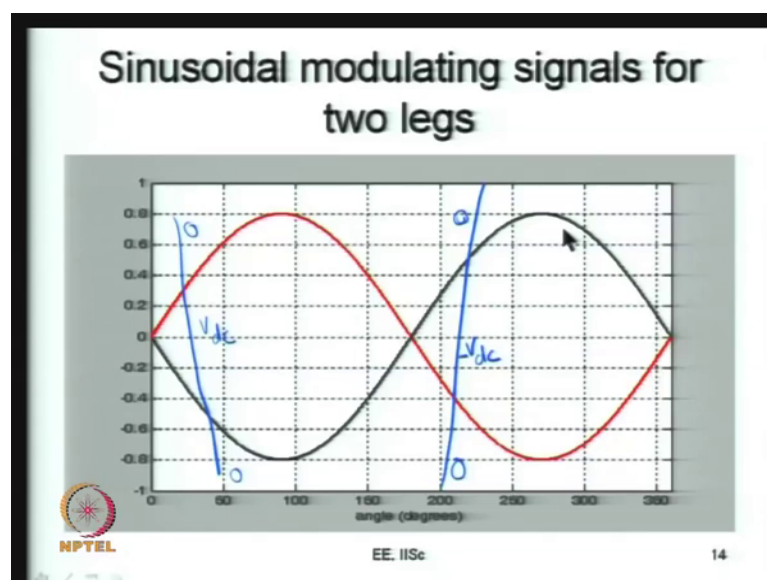

How about V_{BO} we would want the V_{BO} to once again vary in an average sinusoidal fashion, but having the negative value of this. Therefore, your V_{AB} average will be V

AO average minus V BO average are the difference between these 2 and you can see that that will be a sine wave whose amplitude is twice of this sine red or the black sine that is indicated here now. So, what do you do with the individual sine or a how do you enforce this produce such kind of average pole voltage you consider such a sinusoidal signal which you call as a modulating signal.

(Refer Slide Time: 27:31)

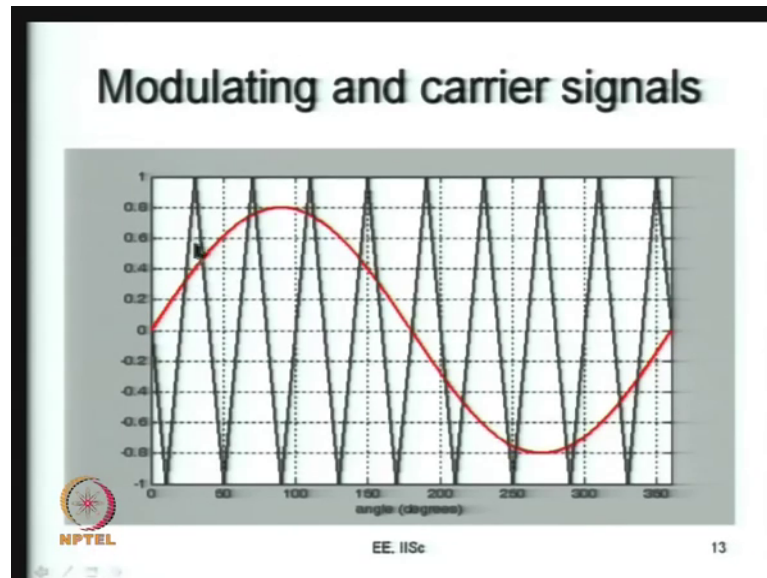

And you compare this signal with a high frequency a triangular carrier which is shown in the black colour here, it is going up and down I have shown a frequency of nine times here, it is could be several times higher than what is shown here is indicative. So, what you do is you compare this sign on the triangle and whenever sine is greater than the triangle you have like here you have the top device on now you see the small interval here in this interval the triangle is greater than the sine you keep the bottom device on this is for leg A similarly you do for leg B.

Once again, if you see here the top device is on within the small interval the bottom device is on the top device is on bottom device is on the top is on bottom is on. So, when you come here you find that the top is on for a shorter time the bottom is one for a longer time. So, in other words, the duty ratio is very high here the duty ratio reaches a maximum here the time for which the fraction of the time for which the top device is on is very high here the fraction of the time for which the bottom device is on is very high or the duty ratio is very low and.

If you take somewhere between 0 around 0 crossing off the sine wave you will see that the time for which the top device is on and the time for which the bottom view is on are more or less equal. So, the duty ratio is around point 5 whenever the modulating signal is close to 0 and the duty ratio is at its maximum when the modulating signal is at its maximum and the duty ratio is at its minimum whenever the modulating signal is at its minimum, the only difference is the modulating signal here is represented as a bipolar signal and the carrier is also represented as a bipolar signal whereas, the duty ratio is a unipolar number. So, it varies above a mean of 0.5; it can go all the way up to one and it can go all the way up to down to 0, in this case what you have is it is about a mean of 0.5, it could go all the way up to 1.

The sine wave can go all the way up to 1 in that case the duty ratio will touch one here, but our sine is not going and touching one instead it is only going to 0.8. So, what you will have is 0.5 plus point for the duty ratio maximum duty ratio seen in such a case only point nine and the maximum the minimum duty ratio seen in this this kind of a case will be 0.5 minus point 4 that will be equal to point one that is the kind of duty ratio you will see here that will be your D maximum and be minimum that is the duty ratio the average pole voltage varies to vary the average pole voltage in a sinusoidal fashion you take a modulating signal which varies in a sinusoidal fashion and you compare it with a triangle like this and you switch the inverter leg.

Whenever the sine is greater than that carrier the top is on whenever the sine is less than the carrier the bottom is on this ensures that you effectively get an average pole voltage like this in this kind of a situation the duty ratio also varies in a sinusoidal fashion, but it varies around a mean of 0.5 that is what I would like to tell you now. So, correspondingly if you look at the B phase also you can for phase you have a sine wave for B phase you have the sine inverted wave this is only 180 degrees they are phase shifted from one another and you can compare them with the same triangle as indicated above. So, whenever the triangle carrier is like the here. So, that is it is greater than both r phase and B phase it is greater than both r phase and B phase in such kind of situation.

What you are going to do is both the cases the bottom devices will be on and similarly when your triangle is here below the negative sign. So, both the sine waves are greater than the triangular carrier then what is going to do happen both the bottom devices are going to be on; so in these 2 cases here when the when the carrier is here the positive

both the part toper when the carrier is here both the bottom are on. So, in these 2 cases the load voltage will be 0 whereas, when the carrier is between this what you will see is let me just draw the carrier on that to get a feel for that. So, let me draw a carrier like this this is a high frequency carrier. So, in this region both the top are on and in this region both the bottom are on.

So, that load voltage is 0 here and the load voltage is also 0 here , but in this region between these 2 intervals you will have the load voltage to be plus V DC similarly you consider a carrier which really goes from here to here you see now you are considering a situation where this B phase modulating signal is greater than the a phase modulating signal in this region you have this as 0, because the carrier is greater than both the sine waves saying both the legs the bottom device is on. And in this case in both the legs the top device is on. So, in both cases it is 0, but in between the voltage applied is V DC minus V DC because here what happens is the B phase is top device is on and here the a phase the bottom device is on. So, you get minus V DC.

So, what if you really do a sine triangle comparison here and you see that in one half carrier cycle in in one half carrier cycle in this kind of a situation you will get the 0 voltage you look at the line you will look at the output voltage you will get 0 and then you will get a pulse of V DC the pulse starting from this instant and ending at this instant. And once again after that you will get 0 and the same thing will repeat in the other direction on the other hand if you look at here you get 0 and you get minus V DC there is a pulse there is a negative pulse of minus V DC and be under you will get 0 once again if you look at the next half carrier cycle will be 0 minus V DC and 0.

So, called a positive half cycle your line voltage will be 0 plus V DC 0 once again plus V DC 0 and so on in the negative half cycle the line voltages will be 0 minus V DC 0, once again minus V DC 0 minus V DC 0 and so on.

(Refer Slide Time: 33:39)

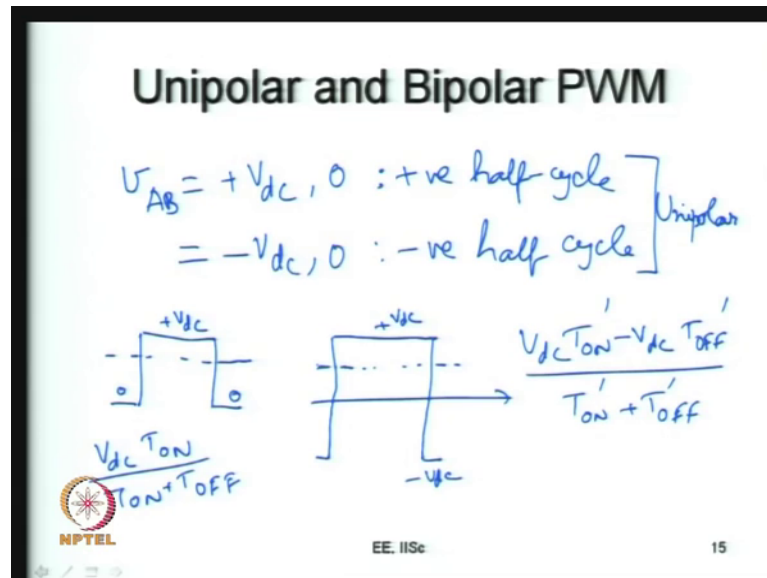

So, this would give you what is called as unipolar PWM that is the output if I write that the instantaneous values that it would take or the instantaneous values V_{AB} can take will be equal to plus or minus V_{DC} and it is not equal to I mean V_{AB} , I mean I would say I am sorry. So, plus V_{DC} I take this off it is either plus V_{DC} or 0 in the positive half cycle in the positive half cycle of the load voltage this is equal to minus V_{DC} or 0 in the negative half cycle. So, this is called unipolar PWM this is called unipolar PWM. So, what are you doing here if you just consider the positive half cycle?

You may apply a voltage pulse like this; this is plus V_{DC} this is 0 this is 0 and the average value is somewhere like this it also possible to get this kind of an average by applying negative voltage also. So, let me say; in the same average voltage you may realize by this is plus V_{DC} and this is minus V_{DC} . So, the average can be somewhere like this and this is the 0 line. So, the same average can be realized either as plus V_{DC} and 0 if I write this down mathematically I call the time as T_{ON} . So, here what you get is the average voltage is V_{DC} times T_{ON} upon $T_{ON} + T_{OFF}$ here it is V_{DC} times some T_{ON} dash and it is minus V_{DC} times some off dash divided by T_{ON} dash plus T_{OFF} dash.

So, whatever is the average voltage I can produce it as a time by time averaging V_{DC} and 0 as shown in the first waveform or I can also do it by time averaging plus V_{DC} and minus V_{DC} as shown in the second example.

(Refer Slide Time: 36:16)

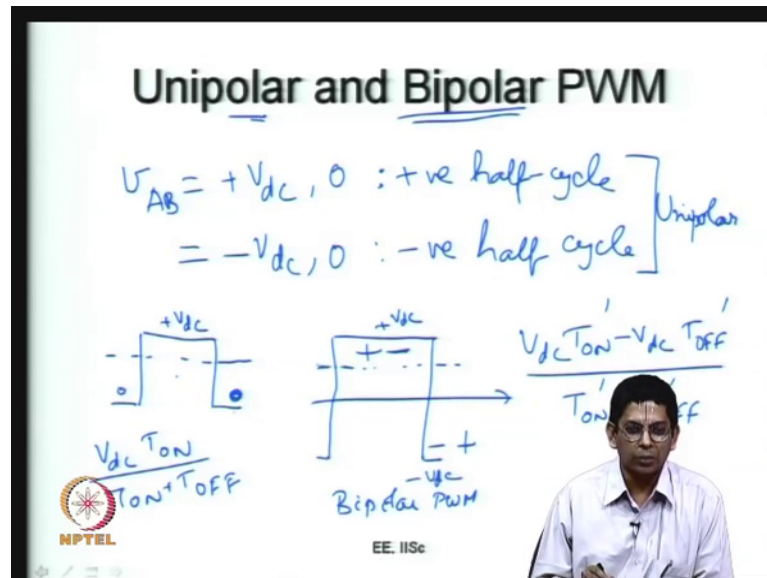

So, this first is called unipolar PWM and the second is called the bipolar PWM because in a bipolar PWM in the so called a positive half cycle of the load you the instantaneous load voltage may be positive or negative whereas, in the case of unipolar PWM in the. So, called positive half cycle of the load cycle the instantaneous load voltage is only positive or 0, it is never negative whereas, if you take the other case of bipolar PWM in the. So, called positive half cycle of the load voltage.

The instantaneous load voltage is either positive or negative it is negative at sometimes, it is positive at some times and hence you go by the term bipolar PWM. So, bipolar PWM anyway is going to give you a worse harmonic discussion which you can very easily see from here how. Now this is dashed line is the average voltage that you want to apply this dashed is the average voltage you want to apply and your actual voltages you are applying a plus V DC and 0 there is an error between what you desire that is this fellow this average value and what you actually apply you cannot you know wish this away because you are trying to synthesize AC using dc. So, you cannot wish this away you do not get have the exact voltages to apply.

So, you have 0 and V DC, but time averaging is synthesizing this in the same way you are here you are trying to do, but here again you are trying to using plus V DC and minus V DC here again this is what you want and what you apply is either minus V DC plus V DC, but as you can really see the error between what you want and what you apply is

lower here and the error between what you want and what you are play is higher here. For example, if this is what you want your supply apply minus V_{DC} . So, the error between the 2 is high in this can tell you that the distortion in the current is going to be higher you can intuitively say if you go for bipolar PWM even without going through lots of analysis it you can say that instantaneously the actual voltage deviates from the desired voltage much more for that what it does here.

So, therefore, bipolar PWM is going to be resulting in a greater amount of distortion, but bipolar PWM is simpler why because in bipolar PWM whenever you apply only plus V_{DC} or minus V_{DC} and whenever you want to apply plus V_{DC} what you are doing is your inverter state is like this A phase positive a phase top device is on and here the B phase bottom device is on otherwise it is minus in plus A phase bottom is on and B phase top is on. So, it is only the diagonally opposite switches are switching. So, it is like only a single control now. So, A top and B bottom are controlled together with the same gating signal similarly B top and a bottom are controlled together.

So, it is very very easy to control. So, it is like controlling only a single switch now, whereas, in this case the 2 legs have to be controlled in the case of unipolar the 2 legs have to be controlled independently. So, bipolar gives you certain advantage in terms of controlling where control circuitry needs to be extremely simple and where discussion does not matter you can probably used bipolar PWM otherwise unipolar PWM is better for your harmonic performance now. So, this already showed you some things on redundancy now for example, when you have this 0, you have this 0, here I am overwriting on this this 0 can be realized through 2 different ways one is both the top devices may be on are both the bottom devices may be on like what we said here if you look at the 0 here.

In this case both the bottom devices are on and if you look at this 0 the la the lower one both the top devices are on. So, this is what I would call as a redundancy in a single phase inverter that is if you look at the output voltages.

(Refer Slide Time: 40:01)

Redundancies in a 1-phase inverter

$V_{AB} = +V_{dc} : A\text{-TOP} \& B\text{-BOTTOM} : ON$

$V_{AB} = -V_{dc} : A\text{-BOT} \& B\text{-TOP} : ON$

$V_{AB} = 0 : A\text{-TOP} \& B\text{-TOP} : ON$
 $A\text{-BOT} \& B\text{-BOT} : ON$

NPTEL
EE, IISc

If you want $v_{ay B}$ to be equal to plus V_{DC} then a top and B bottom these should be on the top device in the a leg and bottom device in the B should be on. Similarly if you have your V_{AB} to be equal to minus V_{DC} you will need a bottom and B top is on this is what we have the what do we do other than that the other voltage is V_{AB} equal to 0 here, we have a redundancy how both A top and B top are on this can give you 0 output voltage, similarly A bottom and B bottom can both be on this will also give you 0 output voltage.

This is what I would call as redundancy we will see more of this particularly we will emphasis this in the three-phase inverter and this is what leads to a lot of pulse width modulation techniques. So, we first in any way we will stop and take a look at here. So, the redundancy if you really look at these are 2 sine waves, these are 2 different sine waves I am sorry, let me this is one, this is one. So, what determines the voltage applied on the load is actually the difference between this waveform and this waveform and not this or this part the lower part it is the difference between the a phase sine waveform and the B phase sine wave form. So, as long as this difference between the 2 is preserved the output is unaffected that is a can be increased slightly higher and B also can be increase in slightly higher.

But in no case a should go beyond one we are taking the peak of our carrier to be one and B also and again B I mean the negative should also not go beyond minus one within

that to a small shift you make such that the difference between the a phase sine and the B phase sine are the modulating signals do not change its still going to work we will see such examples a little later. So, this is what is based on the redundancy of this. So, we let us just note that if you want to apply plus V DC or minus V DC on the load you have no redundancy you have to apply your there is are specific switches which have to be on if you want to apply 0, then there are 2 possibilities both the top devices can be on both the bottom devices can be on, this does not make any difference to the load because the VO load voltage is 0.

But it makes certain difference to the inverter because in this case the top devices are conducting and they are suffering conduction loss they are getting heated up and in this case the bottom devices are on they are suffering loss due to conduction. So, it makes some difference to the devices and it does not make much difference to the load output really speaking. So, this is something that we have to bear in mind we will discuss this later as we go further now.

(Refer Slide Time: 43:18)

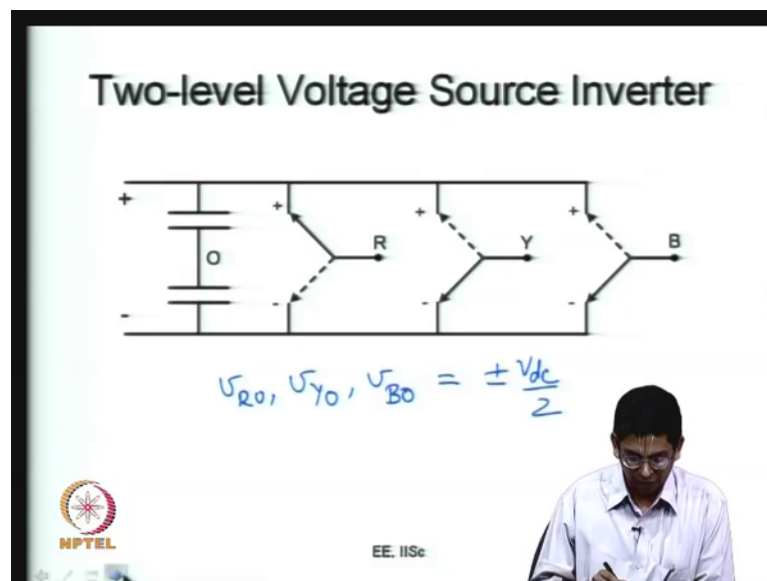

So, here if you look at a 2 level voltage source inverter you extreme that in it is from a single phase you have three-phases a Y and B and you have the DC bus midpoint O you have pole voltages of VRO, VYO and V BO; VRO, VYO and V BO and these can take values of plus minus V DC by 2.

This can take values of plus minus V_{DC} by 2 this is all we have now next step you move on to what.

(Refer Slide Time: 43:58)

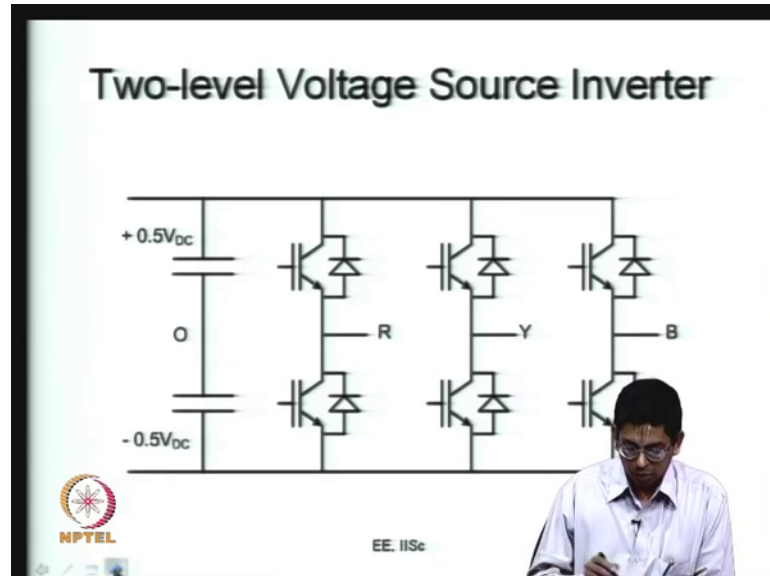

So, this is similar to what we have before you have the switches realized as by directional conducting switches with unipolar voltage blocking capability this is the three-phase inverter in terms of IGBTs and diodes we have already seen this before.

(Refer Slide Time: 44:10)

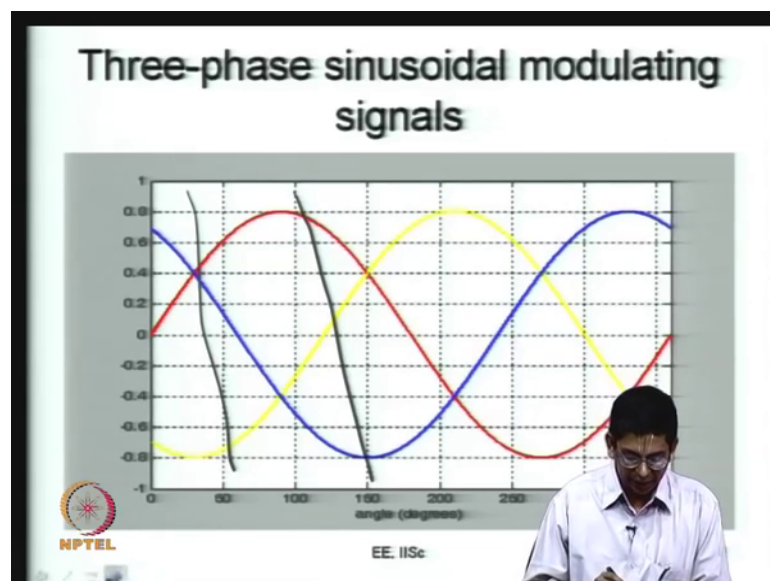

If you are going to modulate how are you going to modulate like in the case of a single phase inverter with unipolar PWM you use 2 sine waves which are of equal amplitude,

but phase shifted by 180 degree that is 360 by 2, here you will have 3 sine waves as shown here, you have this is the red phase this is the yellow phase and this is the blue phase you have 3 sine waves all of equal amplitude and they all have the same frequency this is the output frequency that you want and they have phase shifted by 120 degrees 120 degree is equal to 360 by 3.

So, they have phase shifted like this and what do you do you once again compare them with the triangular carrier with a calm and triangular carrier which goes up and down up and down up and down up and down on this whenever the same logic applies you consider the r phase leg whenever the r phase sine is greater than the triangle let me also draw a rough triangle here, let me say this triangle please ignore my drawing inconsistency there. So, whenever the triangle is higher than the r phase sine the r phase bottom device is on and subsequently whenever the triangle is greater than I mean the sine is greater than the triangle the bottom device is on. And if you look at some other you know that the same kind of logic holds good for y phase and B phase and all other phases.

So, if I draw; if I consider a triangle or carrier like this, this is exaggerated the carrier may not be. So, long I am just exaggerating it here you find a small interval first at the top of the carrier during which the carrier is greater than all the 3 all the three-phase sins. So, during this time all the bottom devices are on similarly you come to the bottom end all the 3 sine waves are greater than this triangular carrier therefore, all the 3 top devices are on here all 3 bottom devices are on all the top devices are on. So, all the line cline voltages are 0 here, here also all the line cline voltages are 0 in between you have certain line cline voltage.

If you look at this interval r top is on and y bottom is on. So, between VRY you will have a positive voltage applied here in this interval. Similarly you find y phase to be greater than B phase here and in this interval why top is and B bottom is on and during this interval VYB you have again plus V DC. So, during the entire interval from here to here your VBR will be equal to minus V DC. So, that is how the voltage pulses will appear if you look at this interval you will find VRY you will get a positive pulse sorry again you look at this interval VOIB you will get a positive pulse and this whole interval starting from this instant to this instant you will have your VBR equal to minus V DC, this is how

you will get your pulses now and here also in the positive half cycle of let us say r phase or RY, VRY if you take.

It has its positive half cycle in the positive half cycle of VRY you will only get positive pulses and 0, you will not have negative pulses. Similarly in the negative half cycle of VRY you will only get negative pulses, you will not get positive pulses. So, this is what it ensures now and this is three-phase sine triangle pulse width modulation now and once again.

(Refer Slide Time: 47:40)

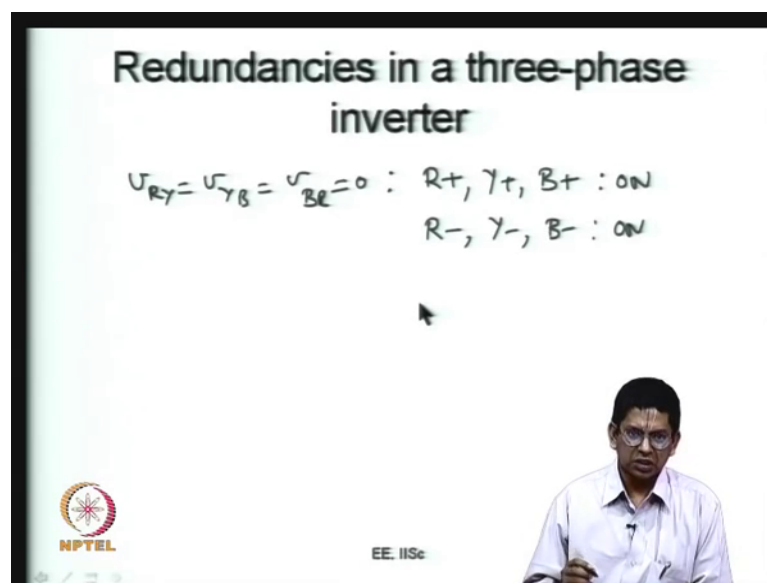

As I indicated earlier there are redundancies there are redundancies what are those redundancies just as we looked at here during this short interval all the bottom devices are on the output voltage is 0 here all the top devices are on and the output voltage is 0. So, for the output voltage to be 0 the output voltage to be 0 that is let me take any of this case VRY is equal to 0 VYB and VBR is equal to 0 in such cases I am sorry.

So, you have situations like VRY equals VYB equals VBR equal to 0, this is possible with all the top devices on that is r plus y plus and B plus by plus I you mean the top devices these are on you can get the same thing if all the bottom devices are also on. So, there are 2 different ways in which you can apply 0 voltage on the load the three-phase load is shorted in both these cases the three-phase load in is shorted, but in one case it is shorted by the top 3 devices. In the other case it is shorted by the bottom 3 devices. So, this state again does not make much of a difference to the load, but it makes quite an

amount of difference to the converter. So, in the first case if you look at all the top devices are on. So, they are getting heated up because of the on account of their conduction in the second case the bottom devices are on.

So, they are getting heated an account of their conduction there. So, you have to use both of them sensibly by and large what we do is we divide this whenever we want to short the load we sometimes short it this way and we sometimes short it the other way most of the PWM methods ensure that the devices their losses are all more or less equal that is how the PWM design is taken care of these redundancies are then what I want to point out is there are redundancies like this and why is that redundancy where is the redundancy in a 2 level inverter the redundancy is in application of what is called a 0 state as we will define a little later where all day 3 that the load a single phase and three-phase load is shorted and you can use this redundancy to design PWM methods.

But how do you do you normally have to design your PWM methods in such a fashion that the different devices do not get heated up to different extents. So for example, you just cannot use this state all the time that is whenever you want to short the load always keep the top on that do not mean that the top devices would get heated up very much and similarly you cannot keep all the bottom on. So, sometimes you have to do this way sometimes you have to use the second option you have to use the 2 in a mixed fashion such that the average loss suffered in any device over a cycle is equal I mean all the 3 legs and the top as well as the bottom devices. So, all the six devices I would say should suffer more or less equal losses how you would design a PWM method now.

(Refer Slide Time: 50:38)

Modulation methods for single-phase inverter

- Bipolar PWM
- Unipolar PWM
- Bus-clamping PWM +V_{dc} 0 -V_{dc} 0
(+-) (++), (-+), (-+)
(+-), (-+), (+-), (-+)
- Even-harmonic injection

$$V_{AB} = V_{A0} - V_{B0}$$

$$V_{AB,av} = V_{A0,av} - V_{B0,av}$$

NPTEL

EE, IISc

so with this background we can really launch on to further modulation methods for signal phase inverter now what are these further modulation methods for single phase we have already seen bipolar PWM in case of bipolar PWM the output load voltage is sometimes plus V_{AB} and it is I mean plus V_{DC} and it is minus V_{DC} and its average value is equal to the desired value.

And in case of unipolar PWM you get your output voltage across the inverter. I mean, we across the load that is V_{AB} will be plus V_{DC} or 0 in the positive half cycle and the average will be as decide in the negative half cycle here it will be minus V_{DC} or 0 and the average will be as decide. So, these are 2 things we considered now and this unipolar PWM is what you get by using 2 sine waves one corresponding to a leg and the other corresponding to B leg these sins are of equal amplitude, but out of phase and compare them with the same triangular carrier now.

You can also going for what is called as bus clamping which is much more popular in the case of a 3 three-phase inverter in which we will discuss in greater detail in three-phase now what do you mean by bus clamping is it is possible that you can keep one of the phases clamped you can keep one of the phase is clamp for example, I have an option if I want to produce plus V_{DC} and 0 what I can do is I plus minus this notation basically means a phase top device is on and B phase bottom device is on this will give me plus V_{DC} and I want 0 I can apply plus plus. So, this is going to give me plus V_{DC} this is

going to give me 0 once again I can go to plus minus and I can go to plus plus. So, this is plus V DC this is 0. So, you see in this case the B leg is switching from minus plus minus plus whereas, the r is not switching at all so over certain interval of time within a fundamental cycle or so.

It is possible for you to get your a leg I mean the first of the 2 legs a leg fixed to the positive DC bus similarly you can also have do it the other way let me you write it with a different color ink now you can start with plus minus minus minus plus minus minus minus. So, this is also possible. So, what do you do here in this case it is also you have its going to produce 0 voltage here. So, here you find that the B leg is not switching at all it is clamped to the negative bus. So, you can do this when you are looking at the V AB positive cycle of half cycle of V AB it may be possible for you to clamp the a leg to the positive bus or clamp the B leg to the negative bus this is bus clamping whether it has any advantages or not we have to see.

But in case of three-phase inverter this has certainly very good advantages now and this bus clamping is more trying out of what is called as even harmonic injection now that is you can inject you can add certain amount of common mode voltage to the 2 sine waves that is the issue. Now we go back to the old 2 sine waves which we had seen here these are the 2 sine waves one corresponding to a leg and another corresponding to B leg. Let us say I add some signal such that r is shifted up I mean the red signal is shifted up little and the black signal is also shifted up by the same extent the difference between the 2 do not change this is what I would mean as common mode injection this does not affect the average output voltage now.

So, what you can do is you can add such kind of common mode and that common mode has to be an even harmonic here why because what you going to do is $V_{AO} - V_{BO}$ your V_{AB} , V_{AB} equals $V_{AO} - V_{BO}$ and even if you take the average is voltages this is average V_{AB} average is equal to V_{AO} average minus V_{BO} average. So, if there is a even harmonic in V_{AO} and I am shifting it by 180 degrees to produce my V_{BO} . So, the even harmonics are the same in both V_{AO} and V_{BO} both in V_{AO} and V_{BO} they will get subtracted and they will not appear in V_{AB} this is whether I consider the instantaneous. So more when look at the average voltages let us say my V_{AO} average is not a sinusoidal waveform, but it is sine plus some small amount of second harmonics

some small amplitude of second harmonic added and I shift it by 180 degree to get my V_{BO} average.

So, it will have the same fundamental, but phase shifted by 180 and the same amount of second harmonic and the second harmonic will be in phase in these 2 a V_{AO} and V_{BO} because I am V_{BO} I am shifting by 180 degree and 180 degree is what one complete cycle for a second harmonic, when I subtract this and that the second harmonic will vanish from here. So, it is possible to add even harmonics this is even harmonic, but it is not particularly advantageous it is particularly in the case of three-phase inverter we will see we can add triple end frequency harmonic we can add third harmonic and that has specific advantages here it is not so much now so, but nevertheless it is interesting to see this.

(Refer Slide Time: 56:02)

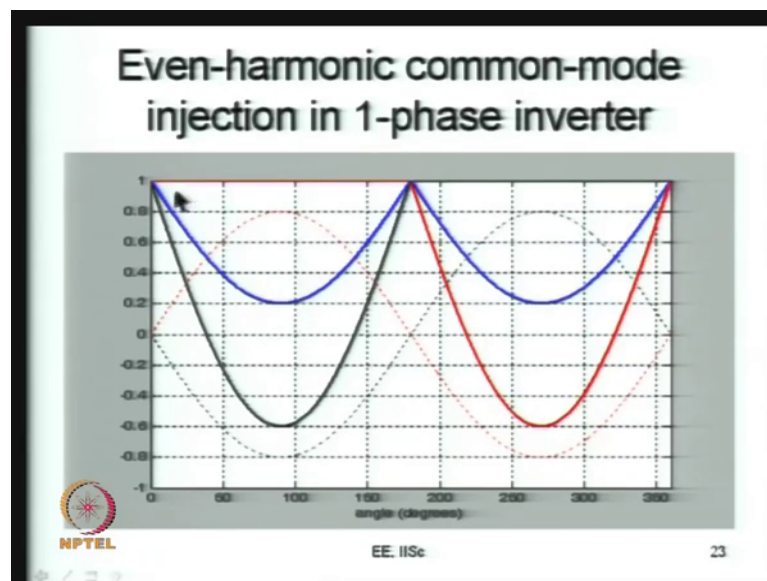

One thing is it can also result in bus clamping that is you can let the device switch only for a shorter cycle now what I have done if you look at here I have taken the same r phase.

I mean a leg signal and I am taken taking the same B leg signal I am just showing them in dotted line now I am looking at a common mode signal which is this blue signal; how did I get this I am actually getting this by subtracting one minus the red signal in the first half and similarly the other difference here in the second half. So, this is my common mode signal and as you can see the common mode signal if you look at the blue

waveform the blue waveform has a periodicity equal to a 180 degrees say it is second this as definitely you know even harmonic signal it has certain average value and it has certain even harmonic second fourth and all these harmonics you would expect for this blue wave form now this common mode blue is signal you add to the red signal in the first half.

So, what happens the red plus blue in the first half becomes equal to this one. So, in this first half a leg does not switch at all it is connected all the time to the top that mean the top is always on and there is no switching here the top may have a continuous conduction loss, but there is no switching loss in the device, whereas the same leg in the other half cycle is switching.

So, effectively the switching frequency of the leg is reduced to half because in one half it is not switching and in the other half it is switching. Similarly you take the other leg this black waveform the same common mode is added that results in a waveform this thick black waveform shown here in this case the B leg does not switch in the second half cycle, whereas it switches in the first half cycle. So, once again you are able to save on the switching. And therefore, it reduces switching loss.

(Refer Slide Time: 58:17)

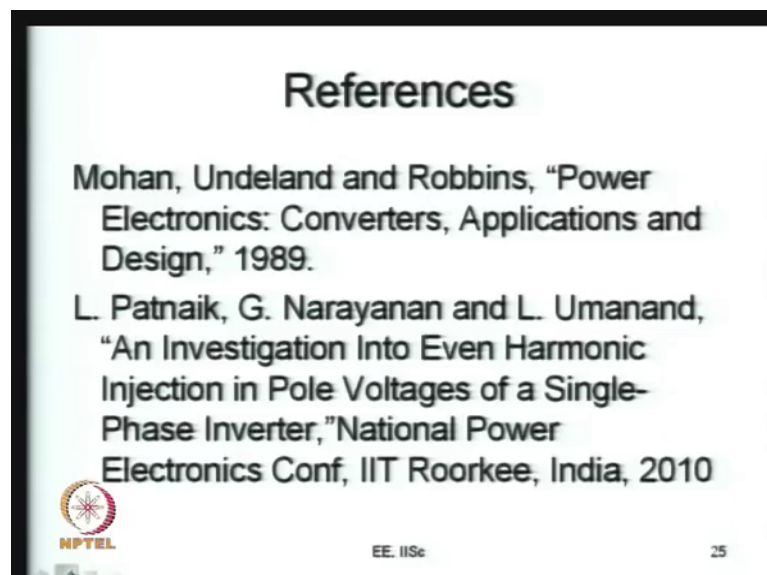

So, we will be able to see more of this in the subsequent lectures where I am I will just illustrate more such examples and these are some useful references for you. And I hope to see you again in the next class, and we will discuss this further.

Thank you very much.