

Pulsewidth Modulation for Power Electronic Converters
Prof. G. Narayanan
Department of Electrical Engineering
Indian Institute of Science, Bangalore

Lecture - 01
Electronic Switches

Greetings, I welcome you to this video course on Pulsewidth Modulation for Power Electronic Converters. My name is G. Narayanan; I am an associate professor in the Department of Electrical Engineering, Indian Institute of Science. So, I work in the area of power electronics, and we offer a course titled the PWM converters and applications or pulsewidth modulated converters and applications here in the department of electrical engineering.

This course, video course sponsored by NPTEL on pulsewidth modulation for power electronic converters is basically an adaptation of the PWM converters and applications course that we offer here now. So, I would expect you know there is some basic amount of familiarity that any student might have with linear circuits and electronic circuits and power electronic circuits, would help somebody follow this course here. So now we get on to our title of this course and you know today I will try presenting an overview or an introduction to what this course is going to be about.

So, the title you find 2 terms: one is pulsewidth modulation, and the other term that you find is power electronic converters. These power electronic converters you know, you should have heard about several converters such as DC to DC converters, right; goes that go by the name my step-down choppers or step up choppers to, and voltage source inverters current source inverters, all these are various kinds of power electronic converters. You use them to convert let us say DC into AC or AC into DC or TC of one voltage level into another voltage level, or you know AC of one frequency to be rectified into DC converted back into AC of another frequency. For all such purposes you need power electronic converters.

So, this pulsewidth modulation is required for operating these power electronic converters. So, this power electronic converter as we will see essentially has several switches. And you need to turn those switches on and off appropriately, and that is what is being done by pulsewidth modulation. You work on pulsewidth modulation, and you

design good methods of pulsewidth modulation to achieve whatever is you know the best possible performance of this power electronic converters. You want to get the best out of power electronic converters that is how why you need pulsewidth modulation. We will be dealing with pulsewidth modulation for most part of this course particularly in the later lectures. But in the initial few lectures we will be focusing on power electronic converters. We will try to see different topologies of power electronic converters, particularly DC to DC converters and DC to AC converters now.

So, this term power electronic converters have this objective power electronic. So, let us try and understand what we mean by this term power electronics. So, in the term power electronics, you essentially have 2 words, power and you have electronics.

(Refer Slide Time: 03:14)

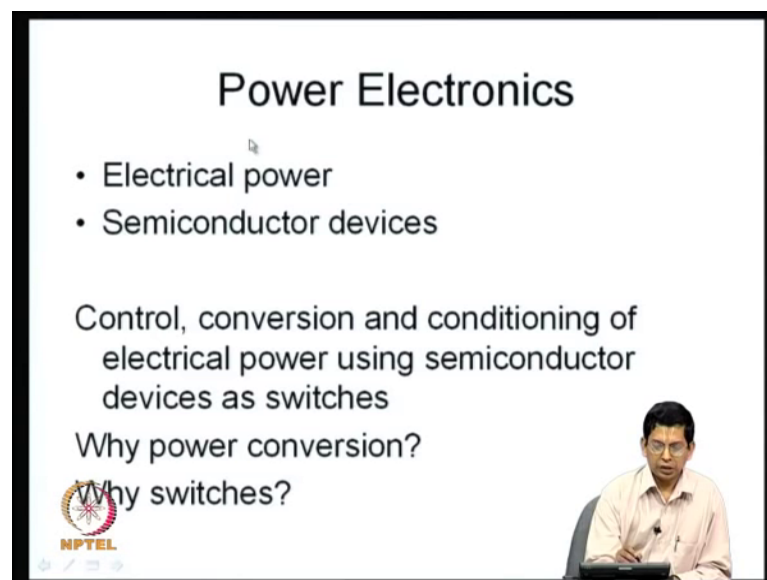

The slide is titled "Power Electronics" and contains the following text:

- Electrical power
- Semiconductor devices

Control, conversion and conditioning of electrical power using semiconductor devices as switches

Why power conversion?
Why switches?

The NPTEL logo is visible in the bottom left corner. A presenter is visible in the bottom right corner of the slide frame.

So, the power here refers to electrical power. And the term electronics refers to semiconductor devices. So, what in essence you do is, you try to control or convert electrical power using semiconductor devices. So, control conversion and conditioning of electrical power using semiconductor devices or switches is one simple way to define what power electronics is. Of course, there are other courses available under this NPTEL which are exclusively on power electronics. Such courses might give you a much better and a deeper understanding of what we mean by power electronics, but this such a working definition should suffice for the purpose of this course now.

So, here when we define this we say there are two things. One is we say this term conversion or power conversion. The other one is we say switches. So, the questions are, firstly you know why do you need power conversion; that is the basic motivation. And why do you need switches to affect that such power conversion. So, these are two questions that somebody made, or what is the connection between switches and power conversion. So, these are two questions that you might you know have on your minds. So, let us first focus on why at all we require power conversion; which is basically the motivation of this whole exercise, so right.

(Refer Slide Time: 04:42)

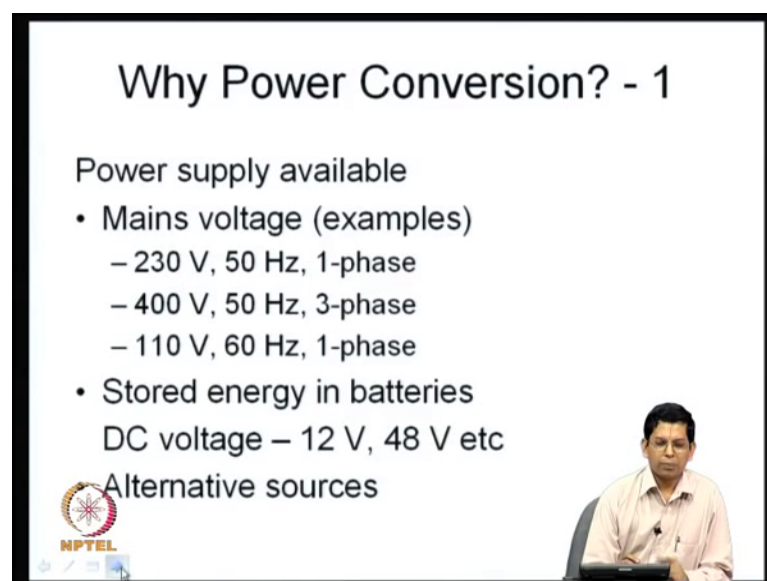

The slide is titled "Why Power Conversion? - 1". It lists the following information:

- Power supply available
 - Mains voltage (examples)
 - 230 V, 50 Hz, 1-phase
 - 400 V, 50 Hz, 3-phase
 - 110 V, 60 Hz, 1-phase
 - Stored energy in batteries
 - DC voltage – 12 V, 48 V etc
- Alternative sources

The slide also features the NPTEL logo in the bottom left corner and a small inset image of a man in a light-colored shirt sitting at a desk in the bottom right corner.

So, why power conversion? See you have electrical power that is supplied to you by utilities. Generally, you know it is supplied in the form of an ac. So, in India, you have 230-volt 50 hertz single phase AC, which is what is commonly available for you. Then you also have 400-volt 50 hertz and 3 phase available. So, depending on whether you have 3 phase loads or single-phase loads, you can either use this 400-volt 3 phase or 230-volt single phase here.

Now, in some other countries and some other parts of the world, you have different kinds of power supplies. You may have 110-volt 60 hertz in some places. You may have 2 naught 8 volts, you have several kinds of voltages. Sometimes it is not 50 hertz, it is 400 hertz. So, a various kinds of power supplies are available from the means. Now this is one source of power for us. Another source of power is often the stored energy in

batteries. So, we have batteries, and you know which store electrical energy. And these batteries provide us with DC voltage are not easy. You connect several of those batteries in series and parallel depending upon your requirements. And you may get you know from a set of batteries you may get up an output like 12 volts or 48 volts of course, with certain amount of regulation and so on.

So, this is what you will get sometimes. So, sometimes you may have AC that is available from the mains, sometimes you may have stored energy. And certain other times you may be relying on alternative sources. By alternative sources, I mean sources such as solar cells for example, or fuel cells and such kind of alternative sources of energy. There you know a solar cell might be giving you a particular amount of DC output, and that is what you have as the power that is available. The form of power in which it is available to you will be some DC there.

(Refer Slide Time: 06:38)

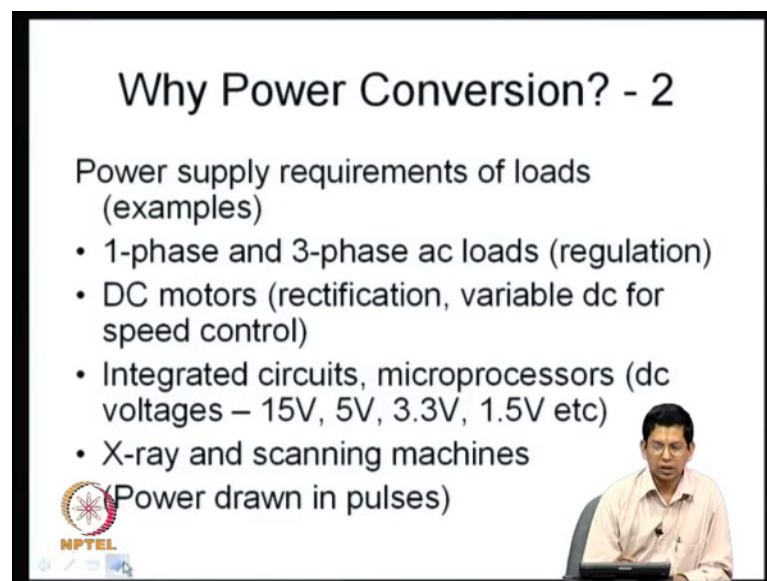



Why Power Conversion? - 2

Power supply requirements of loads
(examples)

- 1-phase and 3-phase ac loads (regulation)
- DC motors (rectification, variable dc for speed control)
- Integrated circuits, microprocessors (dc voltages – 15V, 5V, 3.3V, 1.5V etc)
- X-ray and scanning machines

(Power drawn in pulses)

The slide features a black border and a white background. In the bottom right corner, there is a small inset image of a man in a light-colored shirt sitting at a desk with a laptop. The NPTEL logo is located in the bottom left corner of the slide content area.

Now, you have your loads, the loads have their own requirements. We have many single phase and 3 phase AC loads. Examples of single phase loads are 2 many. If you just look around wherever you are sitting you will find many single-phase AC loads. The bulbs, the electric fan and so on. They are all single-phase loads. Certain higher power ones like you know induction motors for pumps etcetera, you will find that they are 3 phase AC loads. So, the single-phase AC and 3 phase AC loads can more or less be directly connected to the main supply that is available.

Except that some loads may be very, very sensitive to the voltage that is available to them. Quite often in the mains voltage, you know the mains voltage need not be so well regulated. You may say it is 230 volts, but it could be higher than 230 volts for a short duration of time. Or it could be less than that for a short, but considerable length of time. So, these are things that you may call as voltage swell or voltage sag, when you know the line voltage is a little higher than what it is expected or it is a little lower than what it is expected. So many of these loads they do not pose a serious issue except for regulation. You need to regulate the voltage available and feed them if they are very sensitive loads. That is not more or less not an issue now. Of course, regulation is part of what power electronics tries to achieve. It is some kind of conditioning of electrical power.

Now, you say let us say DC motors as loads available. Several machines, you know like lathes etcetera might be using DC motors. And DC motors require DC whereas, what you have is AC that is available from the utility. So, you need to rectify, but also you may have you may rectify it, and let us say a particular value of DC might be available for you. Let me say 110 volts, but this DC motor itself might require a variable DC voltage if you want to for example, you know control you know, operate it at different speeds or whatever.

So, you might sometimes need a variable DC for a DC motor; which is power electronics is something that helps you achieve this too. Now DC motor is one kind of a load. You can have several kinds of loads you know, small integrated circuits on micro process. These typically require DC voltages, they are in a wide range there are several IC's like operational amplifiers etcetera that need some power supply voltage of 15 volts you know, or 12 volts plus minus 15 plus minus 12 and so on. Several other IC's might need a 5-volt supply.

There are also IC's you know the modern IC's and particularly the processes etcetera, they are moving towards lower and lower supply voltages. Today you have a number of IC's, and processes etcetera which operate on a 3.3-volt DC or 1.5-volt DC kind of a power supply now. So, you may have 110 volt available, but you have certain loads which may want 1.5 volt or which may require 5 volts or which may require 12 volts. So, how do you do that? So, the loads requirement is different from what is available. And let us take yet another example. This is a little different. These are x ray and scanning machines.

Let us say in x ray machine, these are examples of cases where you know power is drawn in kind of pulses. There are what I am trying to say is; there are loads which continually draw power and more or less at the same rate. For example, if you have a lamp and if you ignore certain variations with the temperature and time etcetera, it more or less draw continuous power at the same rate. Sometimes the power drawn might vary, but there are certain equipment which draw power in a pulsed fashion and x ray machine is one example of such a thing now, right.

So, this draws power it may be DC. It may be certain amount of voltage, but again the supply you know the current will be drawn in pulses. So, this is; so, there are such kind of loads too, and you can actually go on listing varied kinds of loads and various requirements. And these are just a few examples for us to realize that we have different kinds of loads which have varied power supply requirements now.

(Refer Slide Time: 10:43)

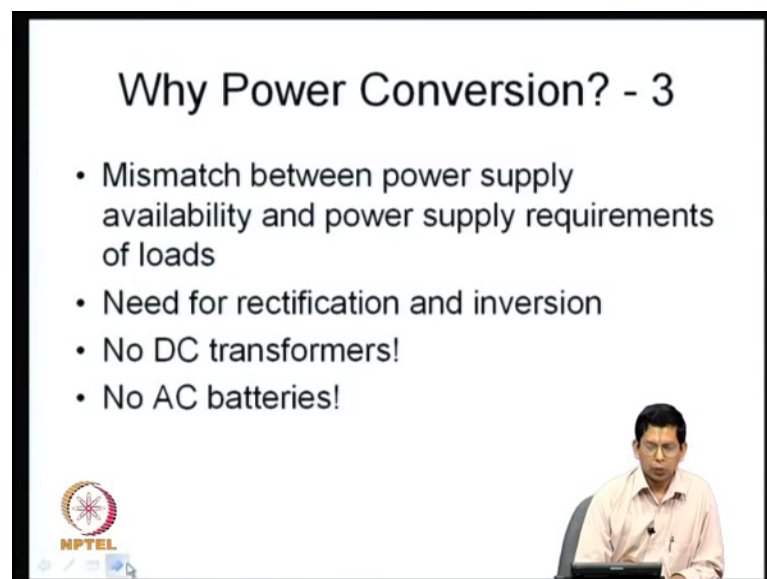

Why Power Conversion? - 3

- Mismatch between power supply availability and power supply requirements of loads
- Need for rectification and inversion
- No DC transformers!
- No AC batteries!

The slide includes the NPTEL logo in the bottom left corner and a video inset in the bottom right corner showing a man in a light-colored shirt sitting at a desk with a laptop, speaking into a microphone.

So, what we have? We have some kind of power supply availability, and we have certain power supply requirements. And there is quite often a mismatch between power supply that is available and power supply requirements of the load now. So many a times, let us say you have AC available, but your load needs DC. So, what you need is certainly rectification. Sometimes you may have DC available with you, like batteries. That is often you know when your mains power fails, your ups provides you power based on you know whatever is stored in the battery. So, in such case what is available is energy

stored in the battery. So, that is in the form of DC. That needs to be inverted to feed your loads, which are all essentially AC loads. So, you need rectification. So, you know quite often you have a need for you know either rectification or inversion or both.

Now, the interesting aspect is; you may rectify and you may have 110 volt or you know some other 200 volt or 200 and 20-volt DC at the 48-volt DC something available. But you may require DC voltages of various levels for your different loads. Now you see we do not have TC transformers. If you have AC of one voltage level, let us say 230 volts, and you expect some 110 volt out of that, you can have a step-down transformer. But there are no such transformers in in the context of DC.

Similarly, again on the lighter side in the lighter vein you have no AC batteries. So, you may have stored energy. And the stored energy is stored in and you know it is available for you in the form of DC. If you have loads which require AC, you know you will need actual AC batteries which are not available now. So, to quote one of my colleagues you know, in one particular reason why you need power electronics is, you do not have DC transformers and AC batteries. So, in a crude sense you can say, one thing that power electronics tries to do is, to make up for the non-availability of DC transformers and AC batteries. It is done very, very differently.

The way a power converter achieves a reduction in DC voltage or an increase in the DC voltage or what is called as you know bucking, boosting or stepping down, stepping up is quite different from the way a transformer works. There is no magnetic circuit, here we use electronic devices. And it is already done through switching action. So, it is quite different, but nevertheless power electronics does help us to step down or step up DC voltages. So, that is a point that I would like to make now.

So, you need power conversion because essentially there is a mismatch between power supply as it is available, and power supply as it is required by loads.

(Refer Slide Time: 13:29)

Types of power conversion

- DC-DC buck conversion (step-down)
- DC-DC boost conversion (step-up)
- DC-AC conversion - voltage source and current source inverters
- AC-DC conversion - uncontrolled rectifiers, phase controlled / thyristor rectifiers, active PWM rectifiers

Power flow – unidirectional or bidirectional



NPTEL

So, there are power there is power conversion we need power conversion. Let us try to list down certain important types of power conversion that we will often require, or kind of classify them in some sense. So, you might have DC that is available, and what you would need may be a DC of a different voltage. And also, your input DC may be unregulated, but you want a well-regulated DC output.

So, you have a DC to DC buck conversion, basically a stepping down you want to get a lower DC voltage from a higher DC voltage. But the lower voltage DC voltage is probably expected to be tightly regulated. Now similarly you may have a DC voltage, and you would want a higher value of DC than what is available. Let us say 100 volt is available, and you need 200 volts. So, what you need is basically a boost conversion or a step-up operation. So, you have DC to DC boost conversion or step up, there is another kind of power conversion that we would often need now.

Then DC may be available and you need AC as I was pointing out earlier. So, you need DC to AC conversion too, and you have these voltage source inverter and current source inverter, these are all power electronic circuits or power electronic converters which try to give you a DC to AC conversion which. Make available an AC voltage or current for your loads as they require. Now there is also AC to DC conversion, which is often called rectification. And the most traditional rectifiers are the uncontrolled rectifiers basically which use diodes. You can use a single diode for a half wave rectifier 2 diodes for a full

wave and you know center tapped transformer. You can use a complete bridge rectifier. And all these I think most of you should be really familiar with uncontrolled rectifiers. Now these uncontrolled rectifiers give you a fairly fixed value of DC. Except for certain amount of regulation, due to loading they give a fixed value of DC voltage for a given line side voltage.

Now, if you want to vary your DC voltage available, what you do is you go for phase controlled rectifiers which are thyristor based rectifiers instead of using diodes here you try using thyristors. Now with thyristors you can control the phase angle you know what is called as the firing angle, and you can control you can achieve different values of DC voltage level. So, you can vary your DC that is available with a fixed value of AC using such converters now. There are another there is another category of AC to DC converter which are actually called active PWM rectifiers, and we will be dealing with them a little later.

So now, these can actually do a rectification, you know drawing almost a sinusoidal current from the mains. These uncontrolled rectifiers will draw pulsating current from the mains. Again, the thyristor rectifiers do not draw a really a sinusoidal current you know, it could be a square wave kind of a current etcetera drawn from the mains, particularly if it is so called continuous conduction or whatever still it is not sinusoidal. These active PWM rectifiers can draw currents which are almost sinusoidal nature now. We will be dealing with this a little later.

Now, the point of caution, that I would like to say is when you say DC to AC conversion or AC to DC conversion, it does not necessarily mean that power only flows from one direction together say DC to AC. It does not mean that power only flows in one direction, because we have some convert converters you know which are unidirectional power flow converters or ones which are bidirectional power flow converters. So, in unidirectional power flow converters, power will be flowing in only one envisage direction, whereas in bidirectional power flow converters power could actually flow in both the directions.

This is the case in some voltage source inverters you know, there is some current reversal you can do this now and active PWM rectifiers. There are certain configurations of

active PWM rectifiers, where you can actually make power flow in both the directions too. So, we have seen a few types of power conversion that we will need now.

(Refer Slide Time: 17:18)

The slide is titled "DC-DC Buck Conversion - A Simple Example". It contains a bulleted list of requirements:

- DC supply of 10V available
- A coil (load) requires 5V dc
- Pulsed waveform across load
- Average voltage = 5V

Below the list is a graph of a pulsed waveform. The vertical axis is labeled "10 V" and "0". The horizontal axis is labeled "t (ms)" with markers at "0.5" and "1.0". The waveform is a square wave that is high at 10V for the first 0.5 ms of each 1.0 ms period and low at 0V for the next 0.5 ms. A handwritten "5V" with an arrow points to the average value of the waveform. In the bottom left corner of the slide is the NPTEL logo. In the bottom right corner, there is a small video inset of a man in a light-colored shirt sitting at a desk.

Let us just look at some examples of how do these. You see these examples are not very, very rigorous examples. These are examples which are meant to give us an intuitive and a qualitative understanding of how we achieve power conversion now.

So, example that we are now taking up is a simple DC to DC buck conversion. Let us say you have a voltage now. Now that is available. Now I have taken it as about 10 volts here. This is just for us to develop a some kind of an understanding of this problem of power conversion. Let us say you have 10-volt DC available. And you have a load which requires 5-volt DC. Now how do you do that? Well, one thing you can always do this, you can have a potential divider and 50 percent of the voltage can be dropped and 50 percent could be applied, but the potential divider has resistances and there is going to be considerable power that is dissipated in the resistors.

We are actually looking for a method of converting power with a very high conversion efficiency. That is the bottom line of power electronics. So, you not only that you need power conversion. You need power conversion with a very high efficiency, that is power electronics right. So, what we are going to do is, we are going to think of certain option how we can possibly achieve this. Now let us consider this.

Let us say I have a load that needs 5 volts. And what I have is 10 volts. One thing that I can certainly do is, I can apply such a pulsed waveform this waveform actually goes on. This 10 volt is applied for half a millisecond, and 0 applied for another half a millisecond. So, in 1 millisecond you have 10 volts applied for half the time, and 0 applied for the remaining time and this cycle goes on. So now, what does it give? You it actually gives you an average voltage of 5 volts here.

(Refer Slide Time: 19:19)

The slide is titled "DC-AC Conversion - A Simple Example". It contains a bulleted list of five points: "DC supply is available", "A load requires 50-Hz ac", "Square waveform across load", "Fourier series expansion", and "Fundamental component". Below the list is a graph showing a square wave voltage V over time t (ms). The voltage is positive for the first half of the cycle (0 to 10 ms) and negative for the second half (10 to 20 ms). The graph is overlaid with a sine wave representing the fundamental component. The NPTEL logo is visible in the bottom left corner of the slide.

So, let me just highlight this to show that. So, this is the average value. And this average value is equal to 5 volts. This is what you can get now. So, you have not been able to get 5 volts continuously, but you are able to get 5 volts in at least in an average sense. So, this remaining whatever is called as voltage ripple, you know it can be filtered out, or it can even be tolerated depending on what your application is in you know to the extent of filtering that might be needed now.

So, what happens you 5 volt you get across the load what happens to the remaining 5 volts. It is dropped where it is dropped across some switch basically. And that switch does not dissipate any power. Let us come to it a little later. Let us first try and understand how we can manage this waveform, what is the square waveform. What I am doing basically is; I have a load. I have the 2 terminals of the load now. What I am going to do is; I am connecting the 2 terminals of my load directly across the supply for 0.5 millisecond. Then what do I do? I kind of short the load for remaining 0.5 millisecond. I

connect it across the supply I short the load. So, whenever I connect the load across the supply I get 10 volts here, and whenever I short the load to itself I get 0. So, I get this kind of thing. So, what do I essentially do? What do we need to do this? I actually need a set of switches, to be able to connect my load to the power supply and also to be able to short the load whenever it is required now.

So, what you basically require is a network of switches. So, that is one reason why you need switch. And let us look at another simple example. This example pertains to what? It pertains to DC to AC conversion we take the same kind of a situation where some DC supply is available. But we take a slightly different situation as far as the load is concerned let us say the load requires 50 hertz AC, but what you have is just DC. So, one simple way to do this is; what you can do this, you can apply a kind of a square waveform which is equal to plus v for 10 milliseconds, and minus v for remaining 10 milliseconds, and this cycle goes on.

So, what are you doing here essentially, you are having a load, and you are connecting the load to 10 volts. Or mean or whatever is the DC voltage directly for 10 milliseconds, then what are you doing; your reverse connecting and for another 10 milliseconds. You really cannot do this and please do not try doing it yourself. This is just only an imagination, and we are just trying to get an understanding of this problem. You connect the load directly across the power supply, and you reverse connect reverse connect. This is what you go on doing, and you get a such a square wave.

This square wave is alternating. No doubt, is it sinusoidal, no it is not sinusoidal, but nevertheless it is a periodic waveform, as we know that any periodic waveform can be expanded into it is Fourier series, and this Fourier series you know expansion tells you that you in this case there is no average, this has 0 average. So, it has a fundamental component of 50 hertz or 20 millisecond periodicity. This square waveform also has components which are 150 hertz, 250 hertz, 350 hertz, and so on. So, such components also exist, but we can choose to ignore them, or we can filter them whatever may be necessary, that my as it might be needed.

Now what I want to focus on is, the fact that it has a fundamental sinusoidal component like this; which I am drawing on this here. So, I am trying to indicate a kind of a sine wave here, which indicates the fundamental component of this waveform. So, you have

started off with your problem of producing AC out of DC. Such an inverter is typically called a square wave inverter. It just produces a square wave out of this thing. So, you can call it a square wave inverter.

Well, is this the best you can do no it is only a starting point and we are just trying to see you know find our way through this problem of producing AC using DC. Which is what we will be doing for a over several lectures in this class now. So, let us say you have a square wave and you want to do better than that. What possibly could be better?

(Refer Slide Time: 23:33)

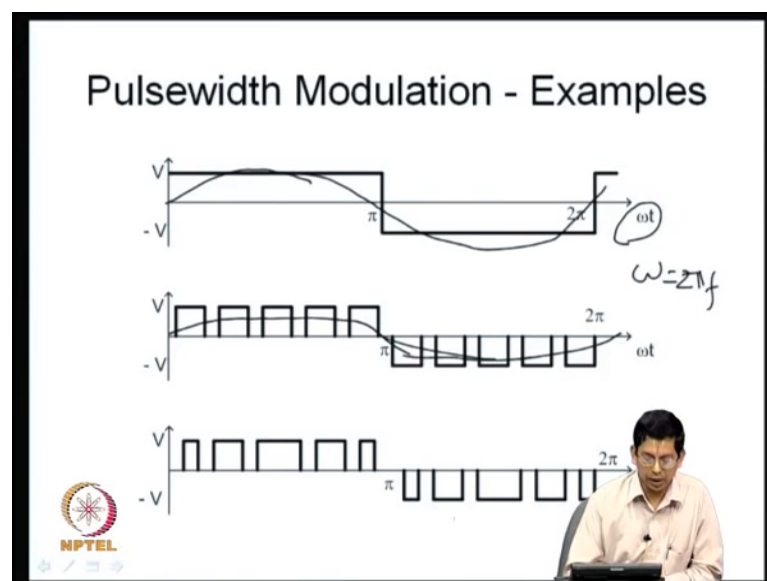

Now, I have given this now. Here once again I have indicated a square wave. This is what we saw last time. Except that I am not indicating in terms of time the horizontal axis instead of time it is omega t that is the fundamental angle, where omega is equal to 2 pi f. So, where f is your fundamental frequency, if f is 50 hertz it is 2 into pi into 50, something like 150 7 point one radians per second is what you will have. And this is omega t is the fundamental angle now. So now, I am indicating a square wave from between 0 to pi it is positive and pi to 2 pi it is negative and it goes on now. So, this square wave does have a fundamental component as I have said before. I am just drawing this fundamental component roughly like this.

Now, this fundamental component has a fixed amplitude. If you want to vary the amplitude what should you do? You must vary this is whatever is available as v the DC voltage. So, that is what used to be done earlier you know, you we used to vary the DC

voltage and then use a square wave inverter to get whatever fundamental voltage you want. But in this course more or less we are going to be talking of fixed DC voltage, we want to invert we want to produce AC using fixed DC voltage. So, the amplitude of AC cannot be modulated, cannot be changed though.

So, what do you do one simple option is actually you know, you can just apply pulses like this. There are several options available; I am just indicating one of them. What you can do is you can apply pulses like this, I have just indicated 5 pulses. It is just indicative. It could be as many as you wish. There is some limit on this because you know it also depends on how fast your devices can switch, you know you have what is called as switching frequency, but now let us say I have indicated with 5. There are 5 positive pulses and 5 negative pulses. In the second waveform I have indicated 5 positive and 5 negative pulses all of equal width.

So, these again produce a fundamental component, but this fundamental components amplitude is a little lower than the amplitude of the first case right. The square wave gives the highest possible amplitude. Now this is pulsewidth modulated. So, you have you know these are 0s also applied; this is a little lower by varying these widths of these pulses. You can vary the AC voltage that is available. This is one way. So, we are just trying to get better it is possible for you to control the AC side voltage available. You can actually do better as shown in this waveform. In this waveform the last waveform you see that there are also 5 pulses, but their widths are different.

And in this case the width is you know broadest at the center and the pulses are narrowest towards the end, which is kind of roughly sinusoidal in fashion the width themselves. So, what you do here is you apply DC pulses right. All these are applied at DC pulses in the so called positive of cycle you apply positive DC pulses, and in the so called negative of cycle you apply negative DC pulses, just an example.

Now, these are widths these pulses are widths and these widths are modulated. And this is you know what you call as pulsewidth modulation. This is a simple example. These are some simple examples of how you achieve a variation in the AC voltage or what is pulsewidth modulation just for us to get a feel for pulsewidth modulation, now. So, it is obvious to the second question, we have post two questions why do we need power

conversion? We had an answer. Because the power supply requirement is something, and the load power supply available is something the road requirement is something else.

And therefore, to bridge the mismatch you need power conversion and what how do you achieve this power conversion using switches. For example, if you want this positive pulse what do you do? You only see 3 voltage levels in the waveform. It is either positive pulse plus v or minus v or 0. So, if you want plus v you should be able to connect your load directly across the DC voltage available. If you want minus v , you should be able to reverse connect the load. Either connected directly will give you plus v you reverse connect you will get minus v . If you want 0 you should be able to simply short the load.

You remember that the load might be inductive typically it is inductive, and it may have stored energy. So, you need to provide a closed path and you know you short that. So, you need a network of switches which can connect the load directly to the DC voltage, and reverse connect to the DC voltage and simply short the load you I mean. This is to let you get a feel for what is necessary. How this network is going to look like is something we will see in the next lecture. So now, this tells you why switches are required. And the interesting part as I pointed out a little earlier was this. See these switches give you an average voltage of 5 volts.

And what happens to the remaining 5 volts? It is dropped across one of the switches, but this drop is without any loss of power. There is a voltage drop certain voltage average voltage of 5 volts is been dropped, but there is no energy lost, why? Switches are either in the on state or in the off state. In the on state their drop is 0. In the off state their current is 0. Therefore, the power dissipated in a switch is always 0. Therefore, you are able to achieve in a drop of 5 volts of an average voltage of 5 volts is dropped, without really suffering you know loss of energy real loss of energy.

So, we need switches and switches help you convert power. And they also help you to convert power efficiently; that is the point that we need to remember.

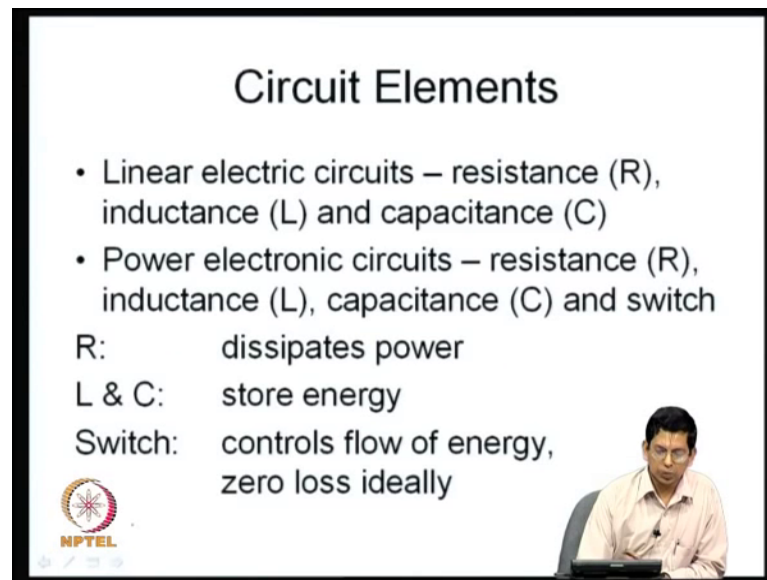

(Refer Slide Time: 29:16)



Circuit Elements

- Linear electric circuits – resistance (R), inductance (L) and capacitance (C)
- Power electronic circuits – resistance (R), inductance (L), capacitance (C) and switch

R: dissipates power
L & C: store energy
Switch: controls flow of energy,
 zero loss ideally

Now, let us say, we go into the question of what we call as power electronic circuits. We are very, very familiar with these linear electric circuits. From this point of linear electric circuits, we would like to understand; what is a power electronic circuit and how it is different. One way to do look at is just look at the circuit elements. A linear electric circuit, what are the circuit elements it has? It could have resistances R. This is another circuit element could be the inductance, denoted by L, and capacitance C. How about a power electronic circuit? A power electronic circuit also has resistance, inductance, capacitance, but just one additional element. What is that additional element? Switch. So, linear electric circuit can have RLC as circuit elements whereas, a power electronic circuit has RLC and switch.

This resistance dissipates power. The inductance and capacitance they store energy. Inductance stores energy as an electromagnetic field, well capacitance stores energy as an electrostatic field. And what does switch do? It actually neither dissipates nor stores. It controls the flow of energy. And it has 0 loss ideally as I just mentioned a while in earlier. Why 0 loss? The switch has only 2 states on straight or off state. During on state it conducts there is some current flowing through that, but ideally the voltage drop across the switch is 0. Therefore, the power dissipated by the switch during it is on state is 0, by virtue of it is voltage being 0.

Again, ideally when the switch is off, there is no current flowing. Through that though there may be a voltage across the switch there is no current flowing through the switch. So, once again ideally the power dissipated or the product of voltage and current is once again 0. So, the loss across a switch is 0 either in the on state or off state ideally. So, you know switches help you convert power with very high degree of efficiency.

(Refer Slide Time: 31:18)

The slide, titled "Power Semiconductor Devices - 1", displays three semiconductor symbols. The Diode symbol has terminals A (Anode) and K (Cathode) with a red arrow pointing from A to K. The Thyristor (SCR) symbol has terminals A, K, and G (Gate) with a red arrow pointing to G. The Power Transistor (BJT) symbol has terminals C (Collector), B (Base), and E (Emitter) with a red arrow pointing to B. Below the symbols is a bulleted list: "Diode is an uncontrolled switch", "Thyristor turned on by triggering its gate terminal", and "Power bipolar junction transistor (BJT) controlled by its base current". The NPTEL logo is in the bottom left, and a video frame of a presenter is in the bottom right.

Now, we have been talking of these switches, where do they come from? Or what are they actually where are they available? These switches are nothing but you know semiconductor devices which we are already aware of. The application could be a little different here from what you know the way you would have dealt within a course on electronics, diode. It is a non-linear element. You would see a diode here, and this diode is a non-linear element. So, what does this diode do? It conducts current in only one direction, and it does not conduct in the opposite direction. So, let me just indicate that way. So, it can conduct only in this direction.

Now when does this conduct? If the diode has been forward biased, then it connects. That depends on the external circuit. If it is forward bias it conducts in this direction. Let us say the diode is reverse biased, what happens? The voltage across the switch is as indicated in red ink here. The cathode is positive with respect to the anode, and it does not conduct. So, the diode is a switch it conducts or it does not connect, but what is the cause? You know what makes it conductor does not conduct is basically, the voltage that

is applied by the external circuit on the diode. So, it is called an uncontrolled switch. It does not have any control terminal of its own. Between this anode and cathode, it can be regarded as a switch, in as much as it connects or it blocks potential, but it is an uncontrolled switch as I have indicated here.

Now, how about a thyristor? Well, it is you know easier to see that when it will be in its off state. When the cathode is positive with respect to the anode, the thyristor does not conduct and cannot conduct. Now not only that may be the anode is positive with respect to the cathode. That is the other possibility. Even in that scenario, as long as the gate has not been fired, the thyristor will not conduct. So, this thyristor can actually keep blocking voltage in either polarity. If it is reverse bias it can block, if it is forward biased it can block as long as gate does not been fired on.

And thyristor is essentially controlled by or rather its turn on is controlled through this gate terminal. And how about turn off? It has to be what is called as natural commutation. The current has to flow below what is called as holding current as you would have studied in other courses, and otherwise you have to use some kind of a forced commutation which will you know apply a negative voltage across the thyristor or make the current force to 0 whichever way it may be. So, the thyristor typically needs either natural commutation or a forced commutation circuit to turn off now, but turning on is controlled through its gate.

Now, you have a BJT: a bipolar junction transistor which is now designed to handle high amount of power. So, I am calling this as a power transistor. Now it has 3 terminals base collector and emitter. Between the collector and emitter, it is a switch. And base is the controlling terminal. You can inject current through the base. You can inject current through the base, to make it conduct. And that conduction is going to be typically in this direction. If there is no current injection through the gate, the thyristor I mean a transistor will not conduct.

So, this is also a switch now. It is a little different, you know in amplifier circuits. You make the transistor operate in the so called linear and active region as it is called. Whereas, in power electronics, you use this transistor, such that the base current is substantially high that is it is driven into saturation or it is in the on state. Otherwise there

is no base current so that it is in the off state. You make you know you make yourself it as a switch now.

(Refer Slide Time: 35:32)

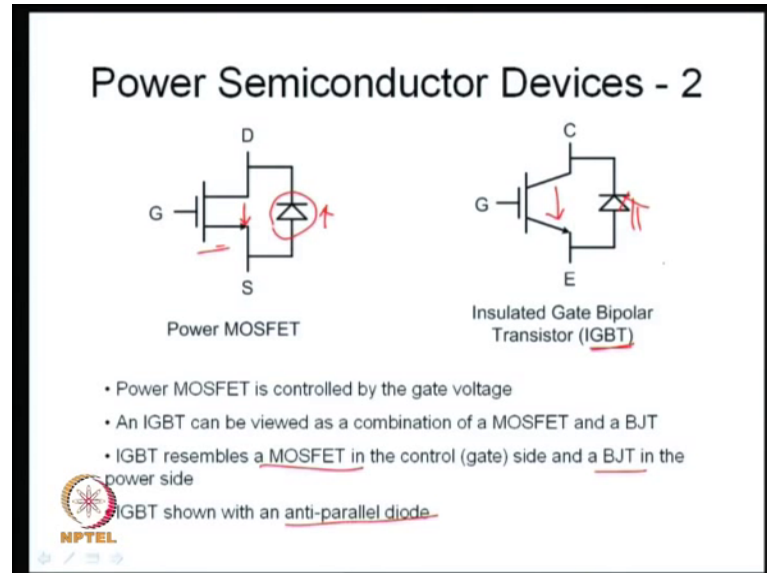

So, these are some important kinds of power semiconductor devices now. Going on to the other kinds of semiconductor device, let us say this is a power MOSFET. A MOSFET stands for metal oxide silicon field effect transistor. So, you have what you have here is a MOSFET now. This is a MOSFET. And typically, a MOSFET has the so-called body diode across it is source and drain. The MOSFET terminals are drain and source, these are it is power terminals and gate is the control terminal. And you can turn it on by applying a positive voltage at the gate above it is threshold; well above it is threshold rather. You can turn it off by applying a voltage which is well below the threshold or this voltage could even be negative.

So, this MOSFET is again a controlled switch which is controlled through it is gate source voltage V_{GS} . And MOSFET typically has a body diode between it is source and drain there is a diode as shown here is formed here. So, this is a complete MOSFET that you normally get for power applications. So, it is a power MOSFET it has a MOSFET and a diode. And you know what you can call as an anti-parallel connection. Because the typical direction of conduction of the MOSFET is this, and the typical direction of conduction of the diode is this. These 2 have been connected in parallel, but you know

their directions of conduction are different. So, you use the term anti parallel to indicate this. So, this is a power MOSFET now. It is controlled by the gate voltage.

Now, you have what is called as an insulated gate bipolar transistor or IGBT. So, what do you do with this IGBT? It is again you know another kind of switch. This IGBT looks like a MOSFET from the gate terminals. But it looks like a BJT from its control power side, now why? So, if you look at a MOSFET, this MOSFET when it is on you know we would ideally expect it to have a 0 voltage, but there is always some voltage drop across any real switch. And the MOSFET behaves like a resistance, and what is typically called as $R_{DS(on)}$.

So, when the current through the MOSFET increases the voltage drop across the MOSFET also increases. And the power is a product of the 2. And therefore, the power dissipated when the MOSFET is on or the so-called conduction loss is proportional to the square of the current that it carries. So, at higher currents MOSFET supports a greater amount of conduction loss. So, if you want you know use a device on higher current applications. What you typically do is; you wish that the device kind of you know behave more as a BJT. Because BJT has what is called as a fixed saturation voltage. So, this is a combination of these 2. MOSFET is very easy to be driven on and off, through it is controlled voltage this gate voltage.

So, you use this. So, BJT is IGBT is a combination of the 2. It has you know it can be easily driven on and off like a MOSFET. And on the power side it has a lower power drop, at you know fairly high ratings if you compare it will have a fairly low drop as BJT you would have now. So, it is basically a combination of these 2. And here I have indicated this IGBT with an anti-parallel diode. Here again the IGBT typically conducts in this direction, and the diode conducts in the opposite direction. This is what you really call as an anti-parallel connection now. So, I have shown an IGBT with an anti-parallel diode here now. So, these are again some other semiconductor devices like, diode thyristor, transistor, MOSFET and IGBT.

(Refer Slide Time: 38:53)

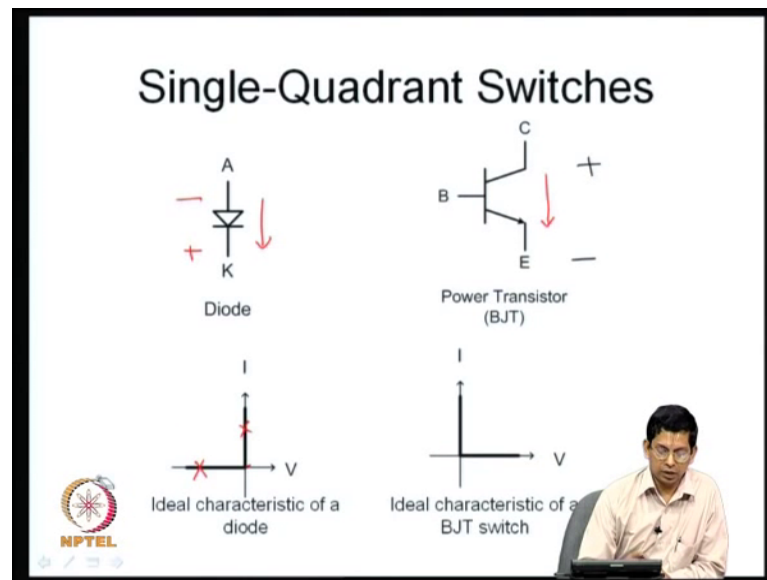

Now, let us look at some more details, on how they operate or what they do. When you say switch, let us say a mechanical switch a switch that you use to control you know to turn on and turn off or a fan or an electric lamp. You know, it is a mechanical switch you press it on and press it off. So, what essentially you have is internally you have a contact and that contact it is just metallic contact or so of a conductor. It makes a contactor opens. So, metallic contact can actually conduct in both the direction, but many of the semiconductor devices or electronic switches may not be able to conduct in both the directions one very good example is our friend diode. He can only conduct in this direction. From this anode to cathode and he cannot conduct in the opposite direction.

So, you have a switch, and when it is on it is conducting, but it can conduct in only one specific direction, and it cannot conduct in the opposite direction. And similarly, this diode, if it is off it can only block with the potential as indicated here. The cathode has to be positive with respect to the anode, otherwise the diode is forward biased it is going to start conducting. So, I have indicated the iv characteristic the current to voltage characteristic of a diode acting as a switch. This is nothing but the idealized characteristic of diode that you are aware of. The actual characteristic you will have a small exponential current going on here.

That is a very small value and you know the voltage drop you really ignore that for voltage drop you get such idealized characteristic. When the diode is on it could be

carrying certain amount of current, I am indicating that current by some point marked on the vertical axis. When it is blocking it could be in when it is not conducting it could be blocking a potential I am marking it by another point here. So, this is really the operating characteristic the idealized characteristic of a diode. And the diode is what is called as a single quadrant switch, because it can only conduct in one direction and it can only block voltages of one polarity.

Now, how about a power transistor? The transistor is also meant to conduct current in only one direction that is from the collector to emitter that is true for all transistors. Now if you have make it conduct like this. Now when it is in the blocking stage, how do you do that? Let me just take a different color to indicate the blocking stage. If it is blocking, that is when there is no base drive it is going to be blocking something of a polarity plus minus like this.

So, it is once again a single quadrant switch, it can block voltage of one particular polarity when it is off, it conducts current in one direction when it is on. If you actually see you know you would have seen the BJT characteristic to be something like this. This is basically when you draw at the collector current versus the V_{CE} , collector emitter voltage for a given i_b or etcetera you will get a characteristic like (Refer Time: 41:43) etcetera like this now. So, you know this is the place where you are going to be operating, that is a small V_{CE} sat. When it is on it is going to have some small voltage, if we ignore that voltage it is the voltage is basically 0. That is the idealized characteristic that I had originally shown.

So, let me erase of this. So, this was the idealized characteristic that I had already shown. And we can regard these switches to be really ideal, for many of our purposes for you know till we reach certain distance. When we start worrying about the losses in the devices and so on so forth long. So, these are single quadrant switches now. So, can we have switches conducting in both directions? Yes, we can do one simple thing.

(Refer Slide Time: 42:31)

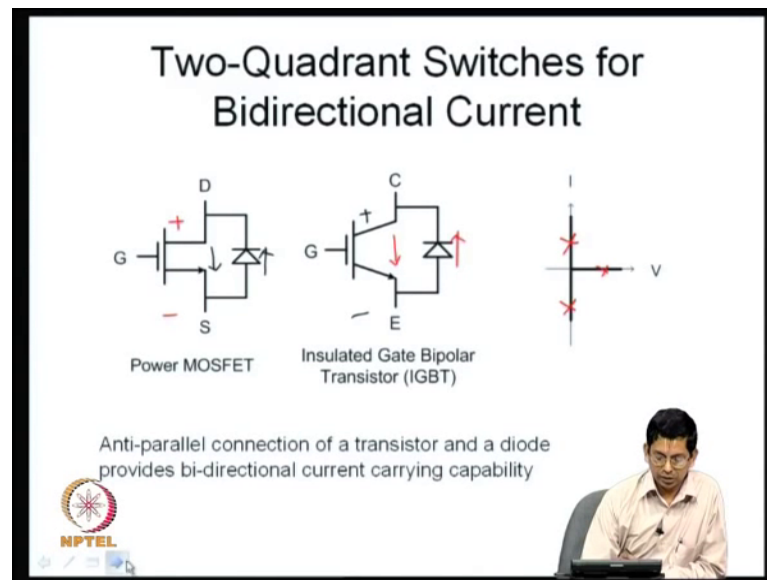

Let us say I have a MOSFET. MOSFET already has a body diode. So, what does it do? You know, once again let me say when it is conducting as I already mentioned it can conduct in this direction, and the diode can conduct in the opposite direction. So, you find that it can conduct in either direction, but how about voltage blocking? It can block voltages with one particular polarity. This is how the way it would be typically connected it will be blocking voltage of this polarity when it is off now.

So, what you have is; it is capable of blocking voltage of one particular polarity, but can conduct in both the directions. So, this is a two-quadrant switch, capable of bidirectional current. Now let us say you have an IGBT, which is almost like a BJT. Now you once again you have an anti-parallel diode connected here. So, the IGBT itself can conduct in this direction, and the anti-parallel diode in the opposite direction. Once again you have a bi-directional current carrying capability, but it is only a unidirectional voltage blocking capability. When it is off, it is going to be a voltage block like this.

So, when it is conducting right. Let me say it could be that it can be carrying a current, if the transistor is conducting. If let us say the diode is conducting it can be a current and this could be the operating point. If it is blocking the operating point could be something like this. So, this is the idealized character characteristic once again of this switch which is an anti-parallel combination of IGBT and a diode now. How do you achieve this? You

achieve this by an anti-parallel connection of a transistor and a diode you have to get bidirectional current carrying capability.

(Refer Slide Time: 44:25)

The slide is titled "Two-Quadrant Switches for Bidirectional Voltage". It features two circuit diagrams on the left. The first diagram shows a transistor and a diode connected in an anti-series configuration. The second diagram shows a transistor and a diode connected in an anti-parallel configuration. In the center is a graph of current (I) versus voltage (V) showing a bidirectional characteristic with a red arrow pointing into the first quadrant. On the right is a schematic of a thyristor. Below the diagrams, the text reads: "Anti-series" connection of a transistor and a diode provides bidirectional voltage blocking capability. Thyristor is a natural option for bidirectional voltage blocking and unidirectional conduction. The NPTEL logo is in the bottom left corner, and a small video inset of a man is in the bottom right corner.

Now, how about the voltage that is something we can look at in the next slide. Now if you add anti parallel connection there, this is something what I call as anti-series connection. I have indicated this anti series within codes because it is not so commonly used a term as anti-parallel is. Therefore, I have put it under codes now. So, what am I doing here? You know it is in some sense I have connected transistor and diode, in such a fashion that they conduct in the same direction, but when you look at their voltage blocking abilities. Transistor will be blocking with this polarity, and the diode will be blocking with an opposite polarity.

So, there are 2 switches, now there are 2 basic semiconductor devices which can actually block in different polarities and the output them in series. So, this is how you can achieve now a bi polar voltage blocking capability now. If the voltage could be of either polarity across the total switch we can call this as a composite switch. Because a transistor by itself is a switch and diode by itself is a switch, when you are realizing you know a switch using more than one switch you can probably call it a composite switch. These composites which has an IV characteristic; idealized iv characteristic as shown here. So, when it is off it could be blocking a potential of either polarity.

And when it is on, it could be conducting certain amount of current as I indicated there. So, this is what you come by combination. There is one device that can naturally give you such an IV characteristic. What is that? That is out front thyristor. So, thyristor is a natural option for bidirectional voltage blocking. As I mentioned while I was talking about thyristor can block a potential when it is reverse biased. Even when it is forward biased, it can continue to block as long as the firing pulse has not been given. Once the firing pulse is given, and as long as the current is above the holding current, it goes above the latching it turns into conduction it is high enough now. High above the holding current or let us say not to complicate things let us say the thyristor is in conduction.

When the thyristor is in conduction, it will continue to conduct in this direction. So, it is unidirectional conduction and a bipolar voltage blocking capability it has, and it has this kind of a characteristic now. You actually tend to use such kind of devices in what are called as current source inverters, and let the ones that we previously saw in voltage source inverter is, we will discuss this a little later. So now, we have two-quadrant switches. Two kinds of two-quadrant switches: one of them has a bidirectional current carrying capability, the other one has a bidirectional voltage blocking capability, when they are in the off state.

Now we want a four-quadrant switch our an AC switch. Now let us say there is a switch, which is used to turn off your fan your ceiling fan, it is an AC switch. Because when the switch is on, it conducts in both the directions right. In the positive cycle of current will flowing one direction, in the negative half cycle of current it will flowing the other direction. And let us say you have kept it off. Then in the positive half cycle of the voltage it will be blocking a positive potential in the negative half cycle of the voltage it will be blocking a negative potential.

So, an AC switch blocks voltages of either polarity when it is off or it conducts current in either direction when it is on. So, how do we get a four-quadrant switch are on AC switch?

(Refer Slide Time: 48:01)

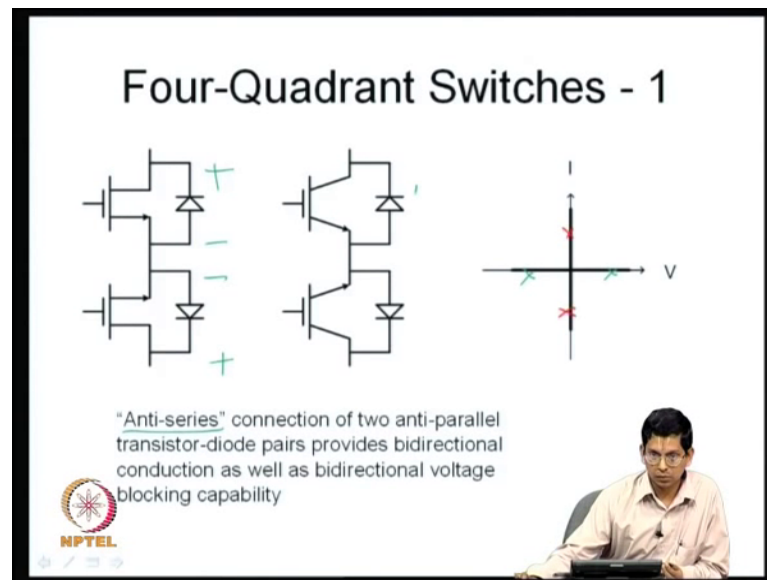

One simple way is; you already have an anti-parallel combination of a transistor and a diode to give you a bidirectional current carrying capability. So now, it has a unidirectional voltage blocking capability. Now you have to take another one, flip it around and connect it in series. And once again what I call as an anti-series, connection just you know it is a question of terminology to have an effective communication. Let us call the anti-series.

So, you go in for an anti-series connection of 2 anti-parallel transistor diode pairs. So, that gives you a four-quadrant switch, you can see it here. So, when it is conducting or when it is blocking, the potential could be either here or here. Somewhere and it could be one point could be either on the negative side of the horizontal axis or the positive side of the horizontal axis. Let us say when it is conducting; it could be conducting a current in the positive direction or negative direction. I am just giving some indicative operating points you know, it could be like that.

So, this you know with the MOSFET is an anti-parallel diode or IGBT with an anti-parallel diode you can do this like as I have indicated here. This also has a similar, it can also take it into the positive and negative and then negative and positive and you can go about doing it the same way. So, this is four-quadrant switches, but is this only way to realize a four-quadrant switch, no. There could be certainly other ways. Now let me go into this. What would be the other way to do that?

(Refer Slide Time: 49:54)

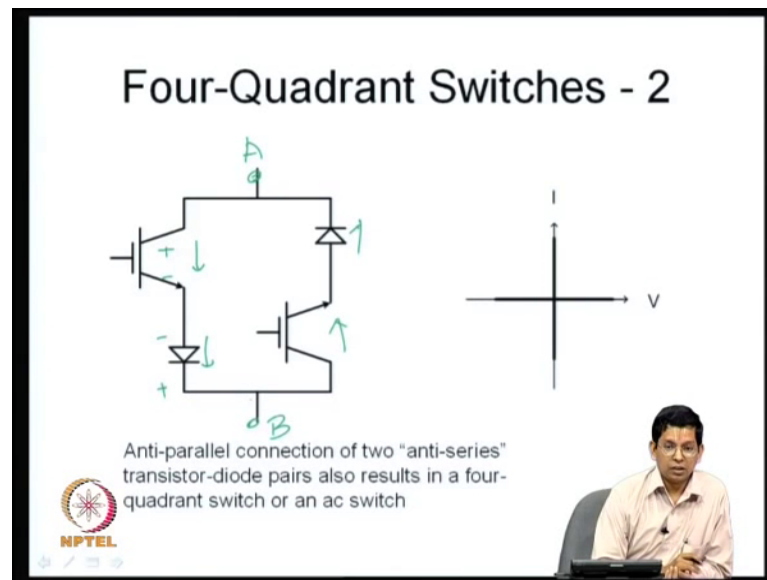

So, this is another way. What I have essentially done is; I have gone for a pair of transistor and a diode which can conduct in a given direction, but can block voltages of bidirectional quality. This is already an anti-series like we have talked about. Again, this is a two-quadrant switch, but a two-quadrant switch more in terms of the voltage not in terms of current unidirectional current, but bidirectional voltage blocking. What I am going to do is; I am going to connect this in an anti-parallel sense with a similar composite switch. So, this is going to give me, you know a capability to conduct both the directions and capability to block potentials in both the directions. So, we once again have an IV characteristic, which is you know which indicates a four-quadrant operation.

So, when it is on the current could be positive or negative when it is off the switch between let us say these 2 terminals can be either positive or negative. It does not mean let me call these points A and B between these 2 points A and B, it is a switch when it is a four-quadrant switch, this is yet another realization of a four-quadrant switch now.

(Refer Slide Time: 51:04)

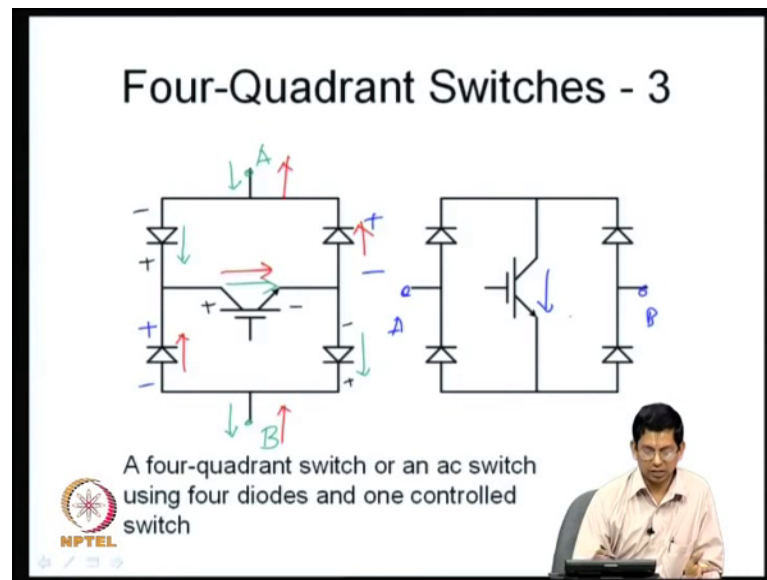

Let us say this is a little more than that, just another realization of how exactly you go about doing it now. What I have try to do is I have used 4 diodes under single transistor or a single control device; four uncontrolled devices and a single control device. Let me call these points as A and B, now these are the terminals of the switch. Now is this a four-quadrant switch yes, let us say you have current flowing in then current flowing out like this. If current is flowing in like it would it can not flow through this diode, but it can flow through this diode. This is the path it is going take. Once again at this node you can see that this is blocked. And this is not going to conduct, this is going to conduct like this. And it is going to find it is path through this diode. So, this is going to be the path of flow the current, when you know the current is in this direction.

Now, let us say the current is in the opposite direction; that is like this. So now, what is the path would be taken by the current? It will be through this diode, and through this transistor once again through this diode. So, you see that the transistor conducts for either direction of the current. And the direction of current is always from the left to right as we have indicated in this figure now right. So, what we are doing is; we are using 4 diodes and one transistor to this now.

There are certain differences when you consider the non-idealities for example, drops. So, this is a case where you know 3 of them conduct at any point of time. So, the conduction loss could be a little higher, whereas, in certain other switches it may be only

2 of them conducting. So, it depends on how you choose I am not going to get into the question of how exactly you are going to choose these switches now. We are more interested in how you can realize these switches now.

So, you can see that this is one way you can go about realizing. So, when it is on it is conducting in both the directions and when it is off it should be able to block in both the directions. So, let us say you know this can block this polarity. So, this diode can block with this polarity, similarly here. So, along this path you see that here is a bidirectional voltage blocking capability. Similarly let me just use a different ink to highlight that. So, this one can actually block with this potential now. So, it can block in both the directions voltages of either polarity, thus, you can release this.

So, what I have drawn here is I have essentially drawn the same thing with a different kind of an orientation where the terminals A and B are here. This is just for us to you know sometimes, we tend to understand better when it is oriented in a particular fashion. So, I just try to give an alternative orientation. So, if you see that the collector point is connected to one, cathode I mean 2 cathodes here you can also see the characters connected 2 cathodes. Here the emitter is connected to the 2 anodes and you can see that the emitter is connected to both the anodes here.

You know, so it is basically the same thing that I have drawn here. The transistor is always going to be conducting in this direction, depending on whether the current flows from our left to right that is a to b or b to a, either these 2 diodes will conduct or the other 2 diodes will conduct. So, what is that? It is actually like a diode bridge. It is a diode bridge with a transistor connected across it is DC terminals. So, this is one way of you know, another possible four-quadrant switch. We extensively use these four-quadrant switches in what are called as matrix converters which are AC to AC converters you need AC switches.

There AC switches of four-quadrant switches. And so, you know these kinds of switches are commonly used, I mean these where you commonly use them where as in voltage source and currents source inverters which we will be dealing with most part of this course we will be using more of two-quadrant switches. So now, I am going to pose a question. In the previous 1 we realized a four-quadrant switch using 4 uncontrolled devices diodes and a single control device or a transistor.

(Refer Slide Time: 55:04)

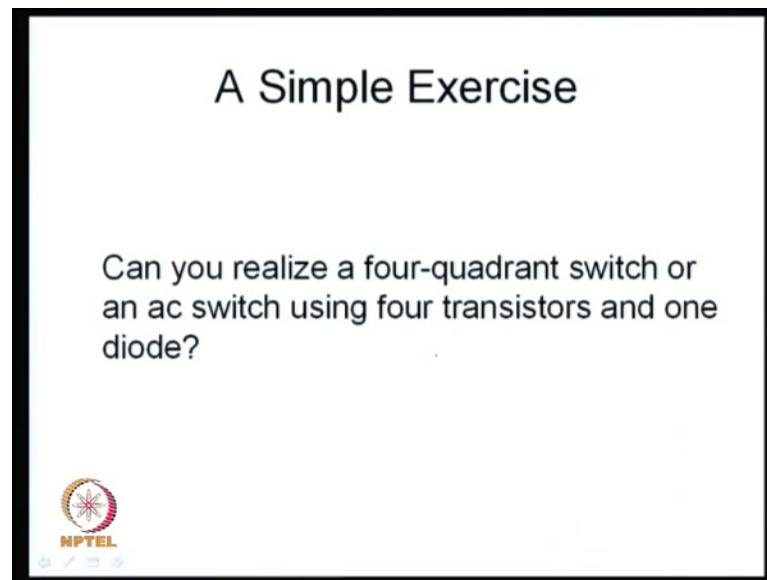

Now, can we just flip it around, can you realize the four-quadrant switch or an AC switch using four transistors and one diode?

I mean that should be possible and maybe it could be obvious to many of you. So, I mean I just request you to in case it is not obvious I mean I would just request you to try and get it now. So, I would just leave you with this simple piece of an exercise. And this is actually the end of our overview, and discussion on electronic switches which is part of our the larger discussion on the power electronic converters, which we will be discussing over about 5 lectures.

Now to recollect what we have been talking of this course is on pulsewidth modulation for power electronic converters, and our initial emphasis in the first 4 5 lectures would be on power electronic converters. And why do you need power conversion this is something that we saw. We have power supply that could be either the mains voltage or it could be battery, or it could be alternative sources, and you have loads and loads of their own requirements. Many loads cannot take the mains voltage or some battery voltage directly you need certain amount of power conversion there. And not only that you may need conditioning to some of this equipment are very, very sensitive to their input voltages now. So, it has to be you know the voltage has to be shaped appropriately they should not be a sag or a swell and things like that and it has to be within a very small band acceptable band of quality. Therefore, you know you need this kind of conversion

that is the reason why you need conversion. And how are you going to achieve conversion? As I said you are going to achieve conversion using switches.

So, switches connect the load to the available source in different fashions. You have a network of switches to do this. So, power electronics is partly about you know power converters if you look at partly about how you connect switches, or how not to connect switches that is what we will be discussing in the next few classes. And pulsewidth modulation is about getting the best out of a given power electronic converter. The power electronic converter that we will be emphasizing will be a 3-phase voltage source converter; that is that has DC on one side and has produces the 3 phase AC voltage on the other that is the converter which we will be looking at most part of the time. Anyway, we will be looking at a range of power electronic converters over the next few classes.

So, with this I thank you for your attention and your time, and you know have a wonderful day. And I certainly hope that this lecture was of some use to you. And I do certainly hope that the remaining lectures will also be helpful to you, and we will have a fruitful course now. Thank you very much, and thank you NPTL for giving this opportunity to give you a lecture.

Thank you very much.