

Power Electronics
Prof. B.G. Fernandes
Department of Electrical Engineering
Indian Institute of Technology, Bombay
Lecture - 19

In the last class we discussed the application of a fully controlled bridge. One of the applications is in dual converter, used for drive application and second application could be in high voltage DC transmission - HVDC transmission. Generally, it is preferred for bulk power transmission.

(Refer Slide Time: 1:09)

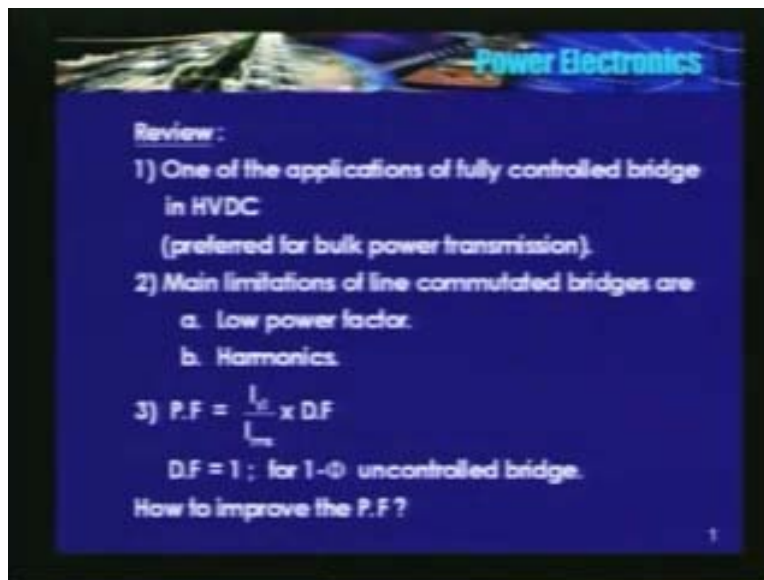

Second point that we discussed was the limitations of line commutated converters. We found that power factor deteriorates as we increase alpha. Second major limitation is source current has harmonics. So, the power factor is given by I_{S1} into I_{rms} multiplied by the displacement factor. So, if I have to improve the power factor, I need to reduce the harmonic content. In other words, I_{S1} should be approximately equal to I_{rms} itself and second one should be displacement factor should be unity.

In other words, conduction should start at the positive 0 crossing. Now, let us see how to improve the power factor? Before discussing this, we will find out the effect of harmonics in the power transmissions or on various equipments. Consider this single line diagram.

(Refer Slide Time: 2:30)

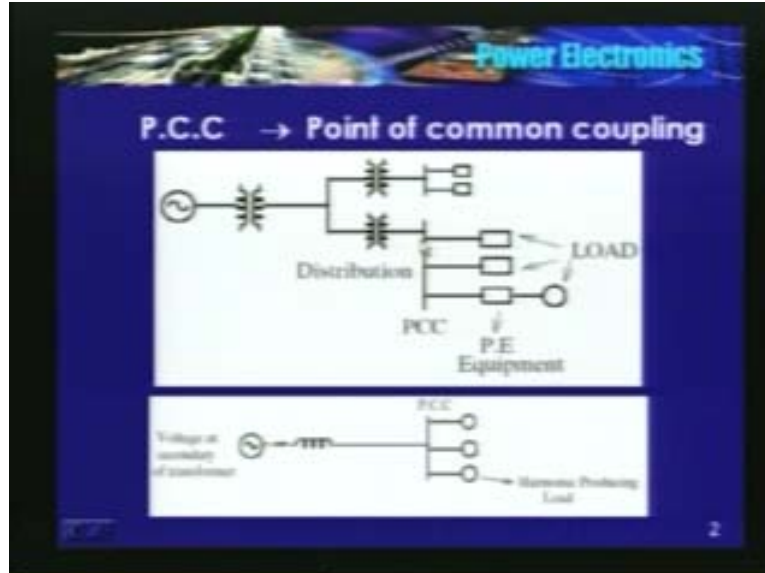

Power that is generated at relatively a low voltage or I can say, it has a medium voltage. It could be of the order of 16 KV or 11 KV. It is stepped out to a very high voltage either 220 KV or 440 KV. Power that is power is generated at medium voltage, transmitted at high voltage. It is received at the receiving station. Voltage is reduced here using a step down transformer and it could be further reduced before distributing to other loads.

So, you may have more than 1 transformer. Consider the high power loads being fed from a medium voltage. All this loads are connected to somewhere at the common bus or this point is known as point of common coupling. One of the loads is being fed from power electronic equipment. So, if I draw a single line diagram starting from distribution system to the load, here it looks like this.

I am considering voltage at the secondary of the transformer is a pure sinusoid. This is the system impedance, could be the including, the leakage, resistance of the leakage, impedance of the transformer and here are the loads, this one being a harmonic producing load. The moment I am feeding it through a power electronic equipment, there are going to be harmonic. Now, what happens? Current that is drawn by this harmonic producing load flows through the system impedance. Even if I assume this to be a sinusoid, because of this system impedance, voltage at this point gets distorted because current is non sinusoidal now.

So, voltage drop across this impedance is going to be a non sinusoidal. Voltage at PCC is difference between this and this voltage. So, this is going to be a non sinusoid. Mind you, all our assumption so far is that input voltage to the bridge is a sinusoid. Now, we found that because of the system impedance, the input voltage to the bridge itself may be a non sinusoid.

(Refer Slide Time: 5:25)

Power Electronics

Current drawn by the load fed from P.E. equipment flows through system impedance.
Voltage at P.C.C is non-sinusoidal
(We had assumed that 'V' is sinusoidal).

3

Here is the 3 phase bridge, pure sinusoid. I have neglected the resistance here. I am assuming load current should be constant and ripple free. So, each device conducts for 120 degrees, source supplies power for 240 degrees. If I assume I_0 to be constant and ripple free, source current is going to be a square wave.

(Refer Slide Time: 6:16)

Power Electronics

$$i_s = \frac{2\sqrt{3}}{\pi} I_0 \left[\sin \omega t - \frac{1}{5} \sin 5\omega t + \frac{1}{7} \sin 7\omega t - \dots \right]$$

= 4N + 1, Harmonics
 -> Line Commutated converter -> causes notches in the source voltage waveform.
 -> Source current has harmonics.

4

I have shown here, it is going to be an instantaneous rise because of the source inductance it may not rise instantaneously. Let us not bother about it. The harmonic spectrum of the source current is given by this equation. I said 3 phase 3 wire system, we can have only 6 and plus or minus 1

harmonics. In other words, fundamental fifth, seventh, eleventh, thirteenth. You cannot have triplet harmonics, you cannot have DC also in a 3 phase 3 wire balance system.

So, since there is going to be a $\frac{di}{dt}$, see, this current is flowing through the inductance. So, there is no $\frac{di}{dt}$, whereas, here there is going to be a $\frac{di}{dt}$. There is going to be a $\frac{di}{dt}$ here. So, because of this, the input voltage to the bridge is going to be a non sinusoidal one. In other words, it has notches. So, these are the notches because of $\frac{di}{dt}$ at this instant. These are the notches. So, source voltage has notches, source current has harmonics.

(Refer Slide Time: 7:44)

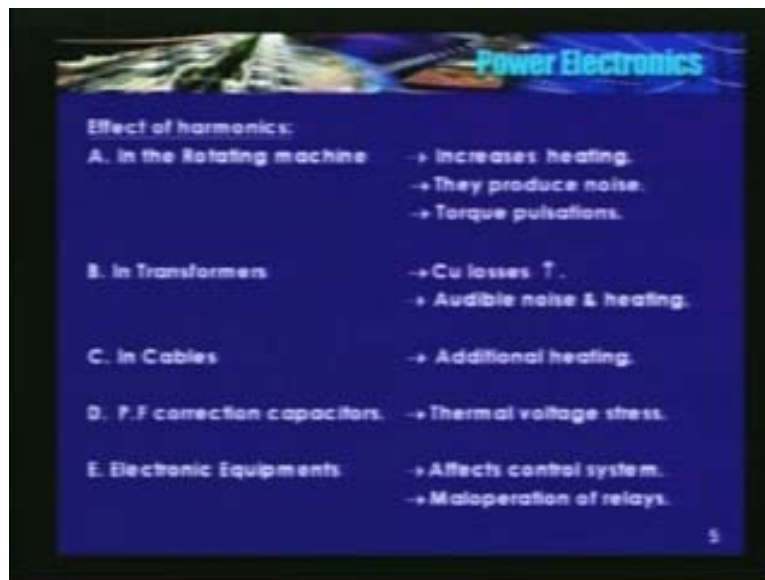

What are the effects of harmonics on other equipments that are connected to the power system? I told you that only the sinusoidal or fundamental component of current and voltage are responsible for power transfer. Other components gives rise to additional I^2R losses, only heating. These currents will flow through all the 3 phase motors. They produce their own rotating magnetic field. They produce their own rotating magnetic field. Hence, they produce a torque which is going to be a pulsating in nature.

So, torque pulsates. If torque pulsates, speed also may pulsate. In addition, they produce noise. What happens in transformer that I connected in the pulse system? Additional noise, high frequency noise and heating because harmonics are flowing, I^2R losses are increasing, therefore heat. Now, I need to cool the system, my cooling requirements also increases.

What happens in cables? That current has to flow through cables. In all the metropolitan cities, power is being fed through cables or in an industry, power is the Me motor, the medium voltage motor may be fed from a 6.6 KV switch gear. It will be located at, inside the turbine building and motor may be located few 100's of meters away. Now, cable has to carry the harmonic current. It gives rise to additional heating.

What happens in a power factor correcting capacitors? I will tell you, power factor correcting capacitors, they are supposed to carry only the fundamental component or a reactive component of the supply current. The frequency is same as that of the supply voltage and ideal capacitor exists only in the text books or in the black board. In reality, you cannot have an ideal capacitor or ideal inductor. So, how do I represent a non ideal capacitor?

(Refer Slide Time: 10:35)

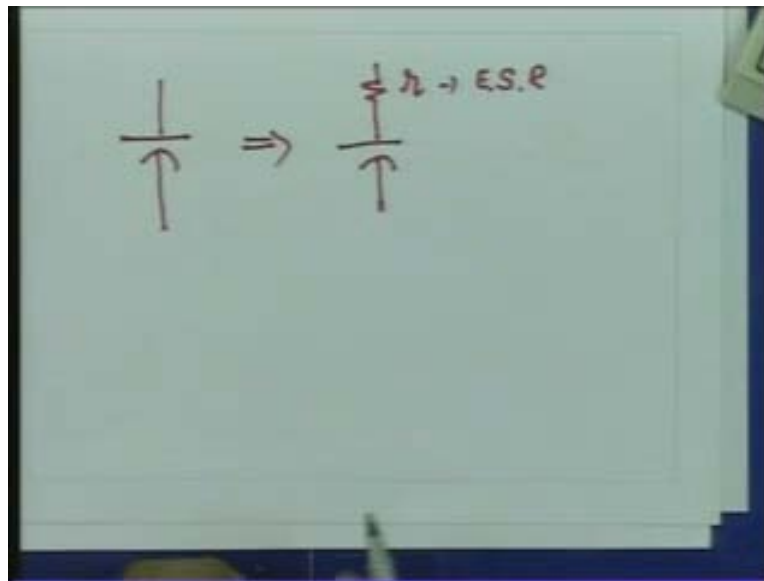

A non ideal capacitor can be represented by an ideal capacitor in series with the small resistance what is known as effective series resistance, R is very small. Another way is to connect a very high resistance across the capacitor. Now, for this case, we will represent a small resistor in series with an ideal capacitor.

This ESR or effective series resistance represents the dielectric loss, the contact resistance and other losses and we all know that dielectric material is a very poor conductor of heat. The high frequency current that are flowing through the line will face a low impedance path through the capacitor. In other words, it is better with the system because the high harmonic currents, since as the frequency increases, capacitor offers a low impedance. So, this current will flow through the capacitor.

In other words, it is better for the system. But then, what happens to the capacitor? In addition to the fundamental component, the reactive component, now it has to carry the high frequency current. Therefore, RMS value of the current that is flowing increases. If RMS value of the current that is increases, $I^2 R$ losses also will increase where R is the effective resistance. So, loss increases, dielectric material is the very poor conductor of heat. It does not radiate the heat very effectively. So, temperature rise and therefore, power factor capacitors may fail.

The last one is electronic equipments. We found that the source voltage itself has notches. Now, your control circuit may sense that this is the 0 crossing, this may be 0 crossing. Actually, there is one 0 crossing here and if the notches, if the system impedance is high, it may become 0 here.

Instantaneous value may become 0 and your control system says that it is another 0 crossing and it takes some other actions.

So therefore, your control circuit may maloperate as well as relays also connected to the system may maloperate. These are the effects of harmonics. Let me tell you one thing, there are various agencies or IEEE, plus IEC - International Electro Technical Commissions. They impose specific limits on the level of current harmonics and voltage notches.

(Refer Slide Time: 13:55)

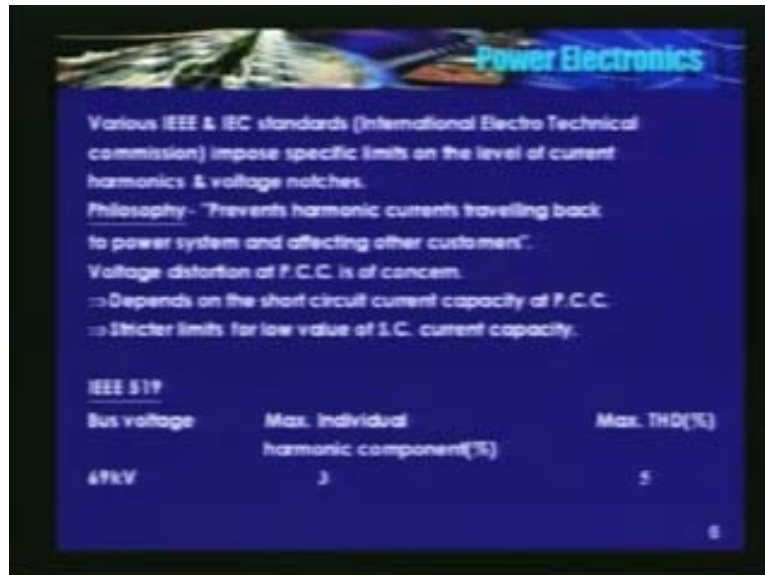

We have gone are the days, like know, I will design a system and I will use it, what happens to the system is not my headache. Those were the good old days. Now, there are various agencies will enforce certain norms. The philosophy is if you are generating harmonics, you do not transmit them to the back to the source and affect the other loads. You better take care of the harmonics that you have produced, that is the philosophy.

In other words, voltage at the point of common coupling should not get distorted. Now, then see, if you see in the equivalent circuit, if I have a very stiff system, in other words, this impedance is very small or in other words, if it is 0, I can allow any amount of harmonics because impedance itself is 0, voltage at this point is been is still going to be sinusoid.

(Refer Slide Time: 14:49)

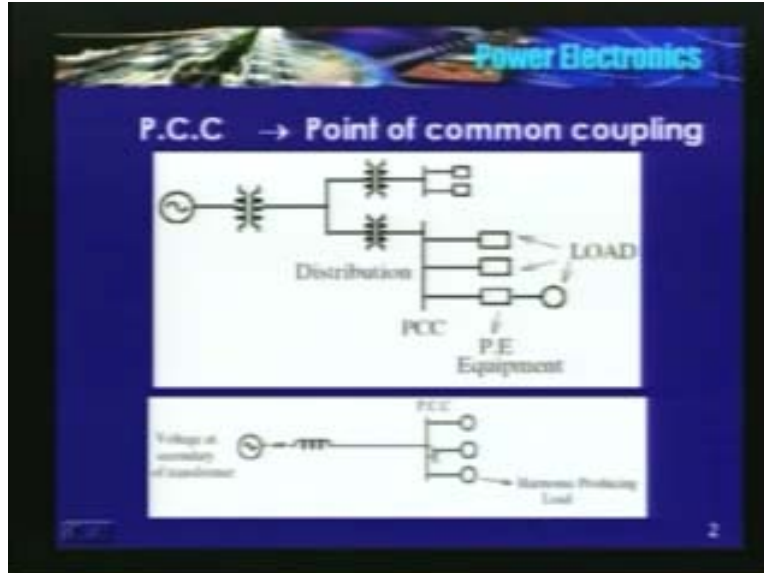

So, as the impedance increases, the current harmonics, magnitude of harmonics also reduces. So, in other words, the harmonic content that **you can**, your load can dump to the system depends on the short circuit capability of the source. So, if the system is stiff, harmonic content can go up. So, basically, this power quality or the harmonic content of various standards is a subject by itself.

I will just give an example. Say, IEEE 419, it is similar to IS - Indian standards, IEEE 519. What it says is if the bus level is 69 KV, the maximum individual harmonic content should be less than 3% and maximum total harmonic distortion is 5%.

So, if you have a 6 pulse converter feeding a load whose current is constant and ripple free and if it is fed from a medium voltage or if it is brought from a 6, 9 bus, you cannot be able to energize your bridge because we found that in a 6 pulse converter, the current is constant and ripple free. THD is of the order of 48%.

(Refer Slide Time: 17:01)

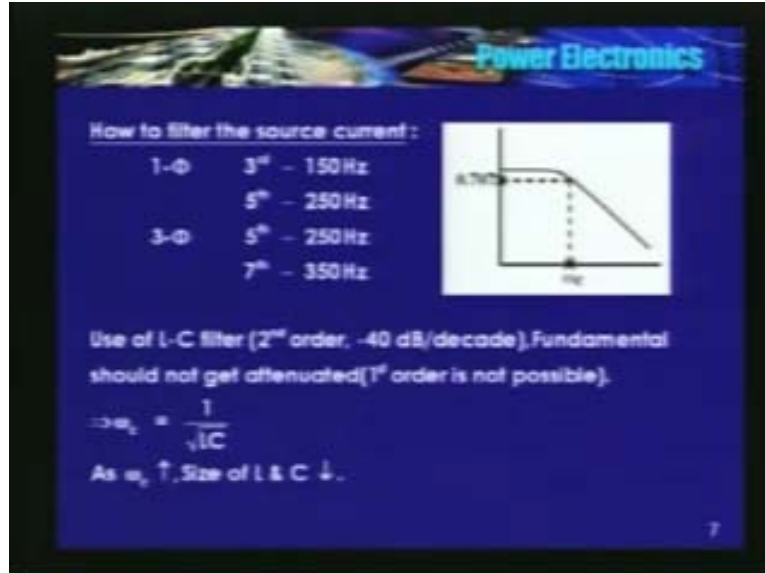

But then now, how do I reduce the harmonics? **because I have to**, my application requires an AC to DC power conversion. In the sense, voltage has to be varied over a wide range. Suppose, my DC motor has to be fed from a power electronic converter, voltage has to vary over a wide range to vary the speed. So, I have to introduce alpha, harmonics will be there. What is the solution?

Now, we will start from using the low pass filters or using the passive components. Can I use the low pass first order filter? You cannot use it. Why? A low pass filter, if I use a first order low pass filter is nothing but a RC, R comes in series with the line or R comes in the path of main power flow and capacitor connects in parallel. You cannot connect a resistor in the path of the power flow because it is going to be an additional $I^2 R$ losses.

So, first order filter is ruled out. Can I use the second order filter, a LC filter? By the way, what is the response of or frequency response of a second order filter? Gain is approximately constant till the cut off frequency or in other words, at cut off frequency, gain falls to 70 volts 70 times and above ω_c the **response is** frequency response is or gain falls at the rate of 40 dB per decade. So, here is the **response of**, frequency response of a second order filter, LC filter. Gain starts falling. It is 70 times ω_c and is minus 40 dB per decade.

So, in a **3** single phase system, predominant harmonic is third. So therefore, the frequency of the third harmonic is 150. Next is fifth, may be, 250, whereas, in 3 phase 3 wire system I have fifth and the seventh, these are the 2 major. Afterwards, eleventh and thirteenth, they are higher frequencies. So, I need to filter, in a 3 phase case, a 250 hertz harmonic and a 300 hertz harmonic. These filters should provide a low impedance path for only these harmonics and should not attenuate the fundamental.

In other words, gain at 50 hertz should be 1 and gain should be 0 at 250 hertz and for another filter, it is 350 hertz. I will repeat; the filter should not attenuate the fundamental component and

it should block completely the fifth harmonic, the seventh harmonic, eleventh harmonic, thirteenth harmonic and so on.

So, is it possible if I use a, if I use a second order filter? Or even if it is possible, what happens to L and C? ωC is given by $1/\omega L$, so, as ωC increases size of L and C decreases. In other words, size of the passive components that are required to filter the fifth, seventh or third are very high, size is very high. In other words, the system will become very bulky. Therefore, bulky occupies large space, cause and what not.

Another thing, I just asked you a question. Blocking completely 50 hertz? Sorry, I will repeat; blocking completely the 250 hertz component and supplying 50 hertz component without getting attenuated a second order filter. I request you to go back to your room and check or see here is it. The gain should be 1, gain should be 1 for 50 hertz, somewhere here and for 250 hertz, it should be 0.

Is it possible? In other words, it may not be possible. So, in order to make the system less bulky or in order to reduce the size of L and C, somehow I need to or I should increase the frequency of the harmonic that has to be filtered. How do I do that?

(Refer Slide Time: 22:49)

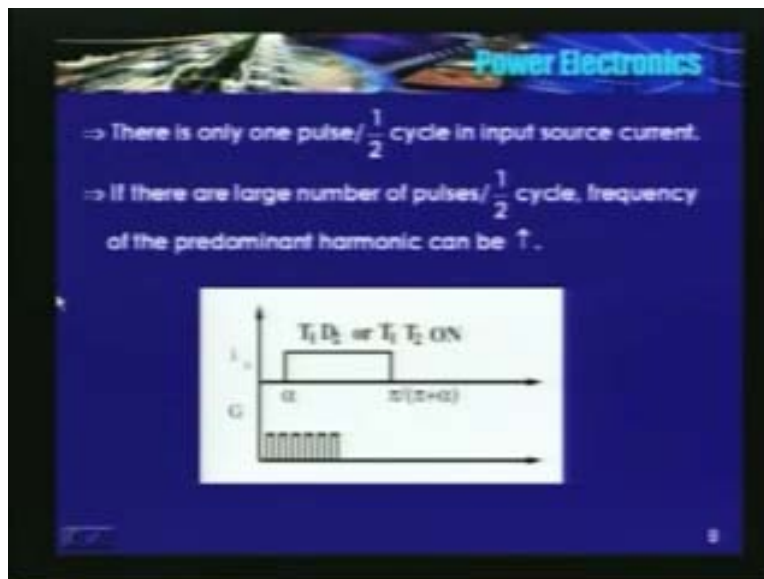

By the way, how many pulses are there per half cycle in all the converters that we studied so far? There is only 1 pulse in 180 degrees. There is only 1 pulse. So, there is an important result which I am not going to prove is that if there are large number of pulses per half a cycle, the frequency of the predominant harmonic can be increased. This is a very important result.

What it says is as you increase the number of pulses in half a cycle, your frequency, the predominant harmonic that is present in the line decreases. This could be proved using bezel functions. If you have time, you derive it. You go and find out. If you not have time, you just accept it. So, this is for a line commutated half controlled bridge, alpha to pi and if it is a fully

controlled bridge, α to $\pi + \alpha$. So, instead of having only 1 pulse, I will chop it into large number of pulses. I will have large number of pulses here. So, I can reduce the harmonic content.

In other words, I can improve the harmonic spectrum or I can increase the frequency of the predominant harmonic. Also, see here, conduction starts at α . So, displacement factor might be proportional to or is a function of α . For $\alpha = 0$, for half controlled and it is α for fully controlled bridge. So, if I have to improve the power factor, I need to make this α is equal to 0. Conduction should start at the positive 0 crossing.

I am reducing the harmonic content. In other words, I am reducing the THD. So, in other words it implies that my fundamental component is same as I_{rms} , I am improving the power factor. So, may be, killing 2 birds using 1 stone may be, because I am starting the conduction at the positive 0 crossing. Displacement factor becomes infinity, I have large number of pulses. So, in other words, the total distortion comes down. If the total distortion comes down, power factor improves. So, at what cost are we doing this? Harmonic content are also reduced, power factor is improved. At what cost? Nothing comes for free. At what cost are we doing this or what modifications, do I need to make in a very rugged half controlled or fully controlled bridge? SCRs are very rugged. **What to** what modifications do I need to make to achieve this?

By the way, I said **number of pulses**, as the number of pulses increases, frequency of the predominant harmonic increases. But, I never spoke about the magnitude of the predominant harmonic. It so happens that the magnitude of the predominant harmonic also gets amplified. But then filtering a high frequency component becomes easier. I told you, because size of the passive components that are required to filter the high frequency component reduces. ωC is 1 over root LC. As ω increases, LC should come down.

Now, coming to the question, how to achieve this? Have a large number of pulses, how do I achieve or what modification I need to make in a fully controlled bridge or half controlled bridge.

(Refer Slide Time: 27:18)

Power Electronics

→ To have large number of pulses / $\frac{1}{2}$ cycle
Devices should be turned ON/OFF
several times / $\frac{1}{2}$ cycle.

→ In the +ve half having triggered T_1 & T_2 .
They cannot be turned off by triggering
 T_3 & T_4 till at $-\pi$
(T_1 & T_2 cannot be turned ON).

A half controlled or fully controlled bridge T_1 and T_2 are triggered in positive half, T_3 and T_4 are triggered in the negative half. **I** the conducting thyristor is turned off by triggering the incoming thyristor. Let me tell one thing, when T_1 was conducting, triggering T_3 in the negative half will apply a negative voltage across a conducting thyristor T_1 and T_1 turns off. We called it as **the line commutation, sorry**. See in this figure, in the positive half you have triggered T_1 and T_2 , potential of A is higher than potential of B in the positive half. So, when T_1 is conducting, cathode potential of T_3 is same as potential of A and negative voltage appears across T_3 in the positive half.

So, having triggered T_1 in the positive half, you cannot trigger T_3 to turn off T_1 . See, I told you, you need to have a large number of pulses here. Definitely, it looks like a device is turned on at this point and device is turned off at this point. There are large numbers of pulses. 0 current implies devices are off or source current is 0. It implies that **power** source does not supply power. Current may be freewheeling in the load that is all.

So, device must be turned off at this point when the current becomes 0. So, in this bridge, in the positive half, T_1 and T_2 were triggered. Now, I have to turn off these 2, but then I cannot turn off these 2 in the positive half by triggering T_3 . In other words, I cannot even trigger T_3 . So, forget about the question of turning off T_1 . So, looks like, I cannot use force thyristors in a line commutated bridge or line commutated bridge cannot be used as it is, to have large number of pulses.

By the way, instead of applying a line voltage itself to the conducting thyristors, I can have additional circuitry which is having LC and may be a voltage source. So, whenever I want to, whenever I want to turn off the thyristor, the conducting thyristor, I will analyze the separate circuit that so called the absolutely circuit that will apply a negative voltage to the conducting thyristor and it turns off. This commutation is known as the force commutation.

We may not discuss the force commutation because those all are out dated topics. Now, there are better methods, better devices are available. The problem with SCR is you cannot turn it off using gate. But then there are devices which can be turned off using gate. They are known as self commutating devices like GTO, BJT, IGBT, IGCT.

(Refer Slide Time: 31:34)

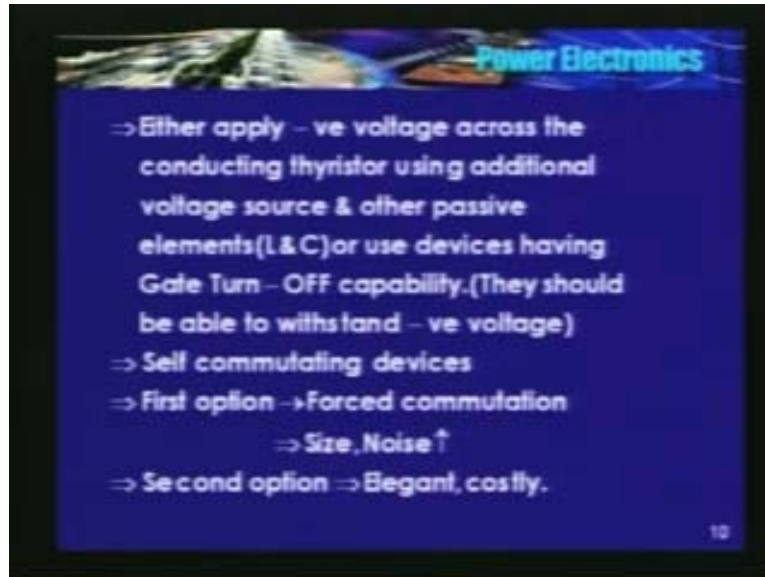

So, to have large number of pulses per half cycle, I need to use the devices which have gate turn off capability. In other words, I have to use the self commutating devices. This option is bit elegant compared to using an external circuitry to put of the conducting thyristor. This is elegant and may be bit expensive. The first one is since, I have to use an auxiliary circuit, my size increases, cost increases and it is noisy.

So, the present day, the trend is to use the second option, using the self commutating devices. Mind you, **there is**, you just cannot use the self commutating device directly in AC supply. They should be able to withstand the negative voltage. I told you that you know, say, 1000 volts BJT may be able to withstand 1000 volts but then it may not be able to withstand 1000 volts in the reverse direction because base emitter junction is highly doped. So, it breaks down faster.

So, if it is 1000 volts in the forward direction, negative may be of the order of 25 to 50 volts or so. So, the device that has to be used in AC should withstand or should be able to withstand the negative voltage because at every half cycle the input reverses. I have been saying that we should have large number of pulses per half cycle so that the frequency of the harmonic increases or THD improves.

But I never said or I never told you anything about the width of the pulse; whether the pulses should be of equal width or when to turn them off, when to turn on the device and when to turn it off, I never told. Or in other words, how do I determine what should be the number of pulses or what is the criteria to determine the number of pulses? When to turn the device on or when to turn it off? The device turning on or off can be determined using what is known as pulse width

modulation techniques. I will repeat, pulse width modulation techniques PWM - pulse width modulation techniques.

There are large numbers of pulse width modulation techniques have been reported in the literature, very large number. The very simple method is the sinusoidal PWM technique, sinusoidal PWM technique.

(Refer Slide Time: 34:58)

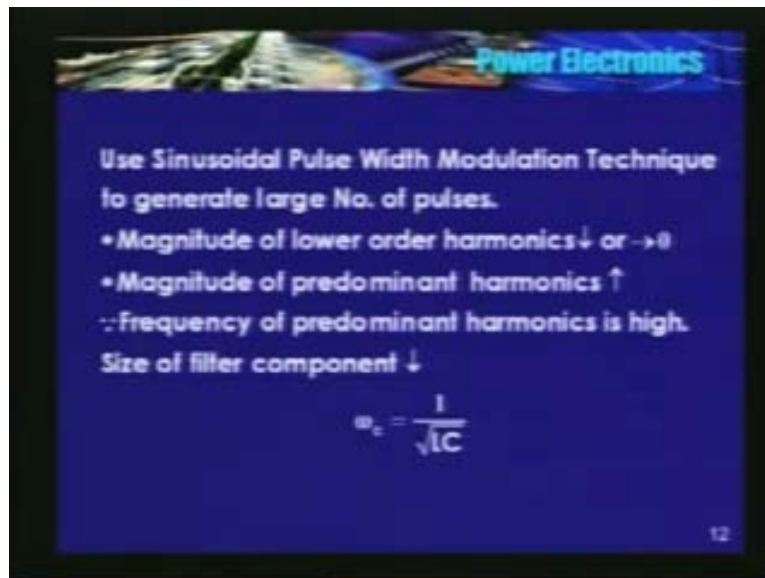

What the technique says, if there are N number of pulses, the frequency of the predominant harmonic is going to be N plus 1 into the supply frequency. In a sinusoidal PWM technique, if there are N number of cycles per half a cycle, remember, N number of pulses per half a cycle, frequency of the predominant harmonic is N plus 1 times the supply frequency.

So, as a number N increases, the magnitude of the load harmonic reduces. In some case it may become 0. I said magnitude of the predominant harmonic may increase, it will increase but then that can be filtered out easily because now the ω_c or the frequency that is harmonic, the frequency of the harmonic that has to be eliminated is very high. So, I need to have a very small size of passive components.

(Refer Slide Time: 36:13)

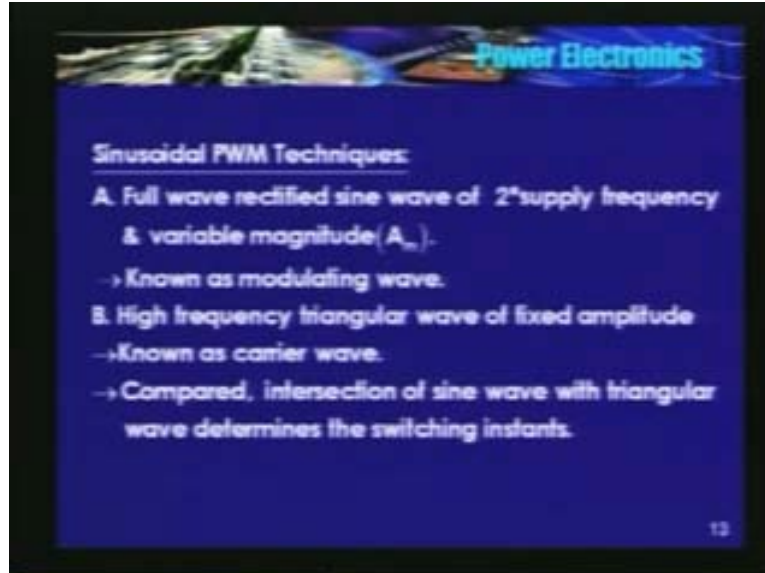

So, in sinusoidal PWM technique, I need to have 2 waveforms. One is a full wave rectified sine wave whose frequency is same as that of the supply wave. In other words, the input supply should be rectified in a full wave rectified. So, this wave form is known as the modulating wave. What is the modulating wave? It is a full wave rectified sine wave having same frequency as that of the supply but then magnitude changing. You can get this wave form by just by rectifying, stepping down and rectifying using a diode bridge.

Second is a high frequency triangular wave, high frequency triangular wave of fixed amplitude and fixed frequency. So, triangular wave with a magnitude is also fixed, frequency is also fixed. This frequency is much higher compared to that of the supply frequency. How high is that high, we will see some time later, whereas, the modulating wave frequency is same as that of that of the supply wave, magnitude controllable.

These 2 wave forms are compared using a simple op amp. Intersection of the sine wave with the triangular wave will give you the triggering instant or the switching instant. Intersection of the modulating wave with the high frequency triangle will give the switching instants. See here.

(Refer Slide Time: 38:31)

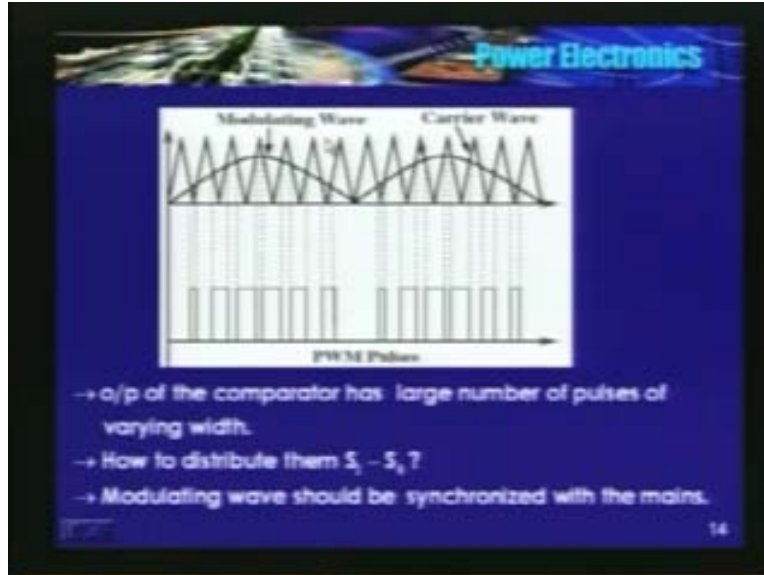

I have rectified a step down version of the supply voltage which is known as the modulating wave. Amplitude is continuously changing or magnitude should be variable. Why? We will see later.

High frequency triangle, both magnitude as well as frequency is the same. Intersection will determine the large switching instant. By comparing a sine wave and a triangular wave, I got a large number of pulses. How do I distribute these pulses to S_1 to S_4 ?

Now, I am calling the bridge as S_1 to S_4 , so far I called, T_1 to T_4 . S_1 implies a controllable switch or self commutating switch, self commutating switch. By the way, we know that alpha is measured with respect to the positive 0 crossing. In other words, this modulating wave should be synchronized with the supply voltage itself.

So, there are various ways to generate this sine wave. If you are using a step down version and rectifying it then there is no problem. The problem starts if you use other means to generate a sine wave. You cannot just take an arbitrary sine wave of same frequency. Say, you can say that supply voltage is 50 hertz, so, here is a signal generator. It will generate 50 hertz, I will take this sine wave and compare it and these are the switching instances, fine. But then what is the relationship between this sine wave which is generated by the signal generator with the supply frequency? In other words, they have to be synchronized, if you synchronize them, it is fine.

(Refer Slide Time: 40:42)

Power Electronics

In the +ve half of input supply if S_1 & S_2 are ON, source supplies power to the load.

- Current is established in the load.
- Assume load current is constant & ripple free

Alternative path for the load current should be provided while opening S_1 & S_2 .

- Either have a freewheeling diode across the load

OR

- Open S_1 only & close S_2
- Load 'I' freewheels through S_2 - S_1 .

In a bridge, in the positive half, if I trigger T_1 and T_2 , source supplies power to the load. In the positive half, T_1 and T_2 on, source supplies power to the load. So, if I keep S_1 and S_2 on, current is being established in the load. So, at this instant, I will **turn it**, turn S_1 and S_2 on assuming that this is a positive half cycle.

For this duration, S_1 S_2 should be on. Source supplies power to the load depending upon the load, current starts flowing and current may build up. At this instant, now the PWM technique says, you turn it off.

Can I straight away withdraw the gate signals to the self commutating switches so that they turn off? You may be able to do this, provided, there is a freewheeling diode, there is a freewheeling diode because having established the current in the bridge or in the load, you just cannot open S_1 and S_2 .

(Refer Slide Time: 44:32)

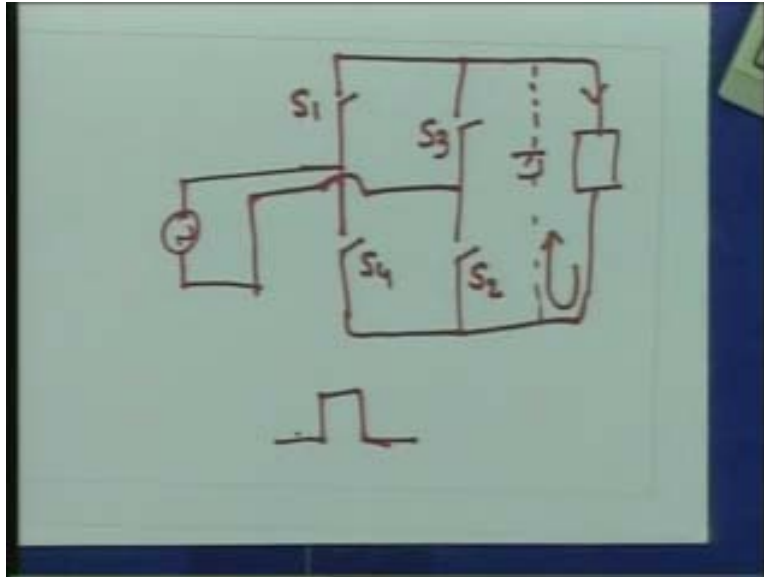

Say, S_1 and S_2 , something like this; had closed S_1 and S_2 , source supplied some power to the load, I established the current. I just cannot open S_1 and S_2 . If I do this, I am breaking an inductive circuit here because I assume that current to be constant and the ripple free, same assumptions that we made for the SCR bridge or fully controlled bridge.

So, if I am opening S_1 and S_2 , I have to provide an additional path for the current to flow. But the control scheme or the switching technique says that open S_1 and S_2 now. So, if I open S_1 and S_2 , either have a freewheeling diode across the load because the moment I open S_1 and S_2 , current freewheels to the load. It was flowing in this fashion, now it will flow through the diode what is known as the freewheeling path or what I will do is I will not open S_2 . I will open S_1 and close S_3 .

What I will do is, in this instant when device is to be turned off, when the device is to be turned off, what I will do is I will open only S_1 and I will keep S_2 closed and while opening S_1 , I will close S_3 . So, current will freewheel through S_2 and S_3 .

So, in the positive half what I will do is I will permanently close S_2 . Whenever I want to supply the power to the load or whenever the control circuit says that supply power to the load, I will close S_1 and when the device has to be turned off, I will open S_1 only and I will close S_3 .

So, trigger pulse sequence for S_1 and S_3 should be complementary in nature. The pulses for S_1 and S_3 in the positive half should be complementary in nature and S_2 is closed for 180 radians, entire positive half. Why entire positive? Why? Why only positive half? because first thing is **I have to**, the conduction should start at the positive 0 crossing.

In other words, T_1 and T_2 should start conduction in the positive half or S_1 and S_2 should start in the positive half. So S_2 , I will close it for entire pi radians. In that case, now what will happen?

Displacement angle becomes 0, displacement factor unity. So, there are large numbers of pulses. S_1 should be turned off now. I will open S_1 , close S_3 . So, this has to be complementary.

What will happen in the negative half? Same thing, in the negative half, S_3 S_4 should be on. S_3 S_4 should be on, only then source supplies power to the load. I just cannot open S_4 S_3 . Now, what I will do is I will close S_4 permanently for 180 radians. So, whenever I want to open S_3 , I will close S_1 , open S_3 . So now, the current freewheels through load S_4 S_1 , S_4 S_1 . So, this is the control strategy.

(Refer Slide Time: 47:20)

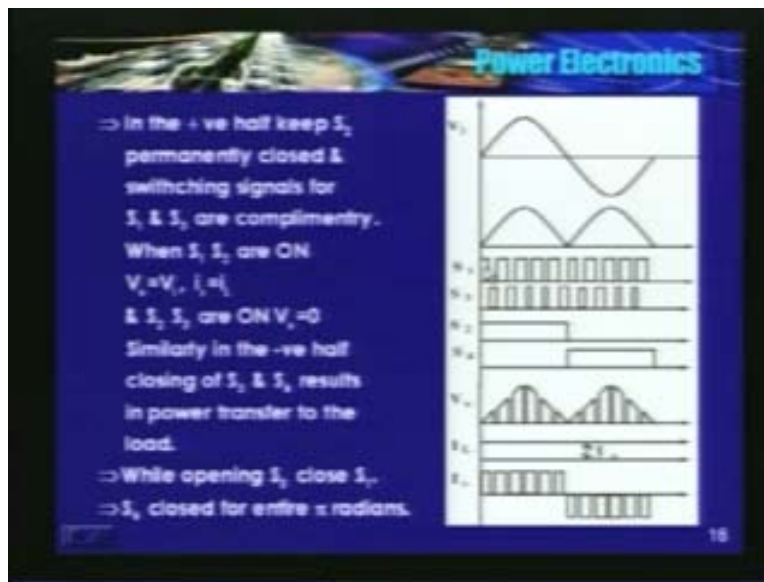

So, here are the waveforms. Input voltage V_1 , I have rectified it. This waveform, I compared with the high frequency triangular, had a large number of pulses. Somehow in the positive half, S_1 and S_2 should be on to supply the power. So, I kept S_2 on for π radians, triggered on and off several times. This depends on the pulse width strategy. So, whenever I am closing S_1 , S_3 is off and whenever I am opening S_1 , S_3 is on. Same thing is happening in the negative half or from π to 2π .

How does an output voltage look like? Whenever S_1 and S_2 are on in the positive half, output voltage is same as input voltage. So, when S_1 is opened and S_2 S_3 are on, load voltage is 0, freewheeling period, waveform is very simple.

When S_1 and S_2 are on in the positive half, input voltage is same as the output voltage and when S_1 off, S_2 S_3 on, load voltage is 0. So it is nothing but a sinusoid, chopped sinusoid. S_1 S_2 on, this is the freewheeling period, S_2 S_3 , again S_1 S_2 on or in this period somewhere here S_1 S_2 may be, so on.

So, output voltage is chopped sinusoid. This instant is freewheeling period, this is the powering period. Same thing happens in a, from π to 2π here S_4 S_3 on and in this region S_1 S_4 on. How does the source current look like? Same philosophy, I assumed current to be constant and ripple

free. So, when S_1S_2 on, load current is same as the source current and during freewheeling period, source current is 0. Current freewheels through S_1 and S_4 in the negative half or from π to 2π , S_1 and S_4 and from π to 0 to π , 0 to π , it is S_2S_3 . So, this is freewheeling power, current is 0 here. So, source current is also having large numbers of pulses. Mind you, these pulses are continuously changing because if you see, these pulses are continuously changing here.

(Refer Slide Time: 50:41)

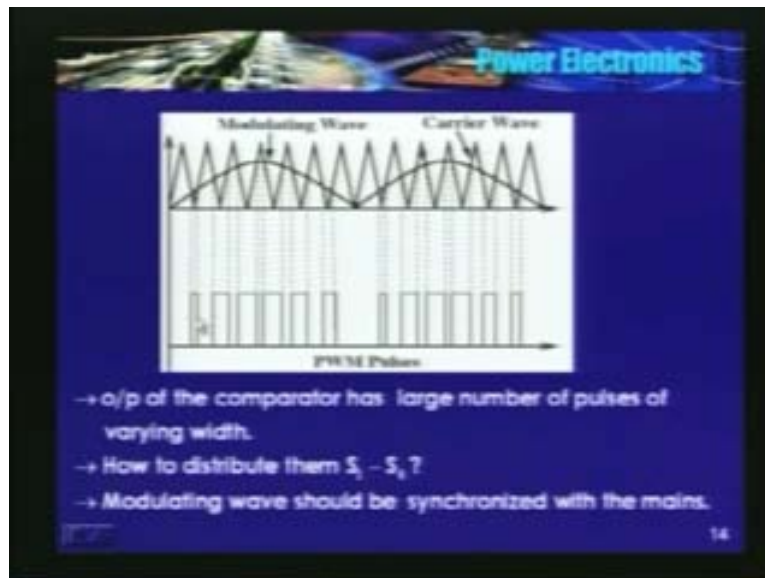

We have at somewhere near the 0 crossing, I have a very narrow pulse. As ωT increases, this pulse width increases. So, pulses are sinusoidally changing, pulses are sinusoidally changing. Mind you, this should be symmetrical. Hence, the name pulse width modulation technique, pulses are continuously changing.

(Refer Slide Time: 51:13)

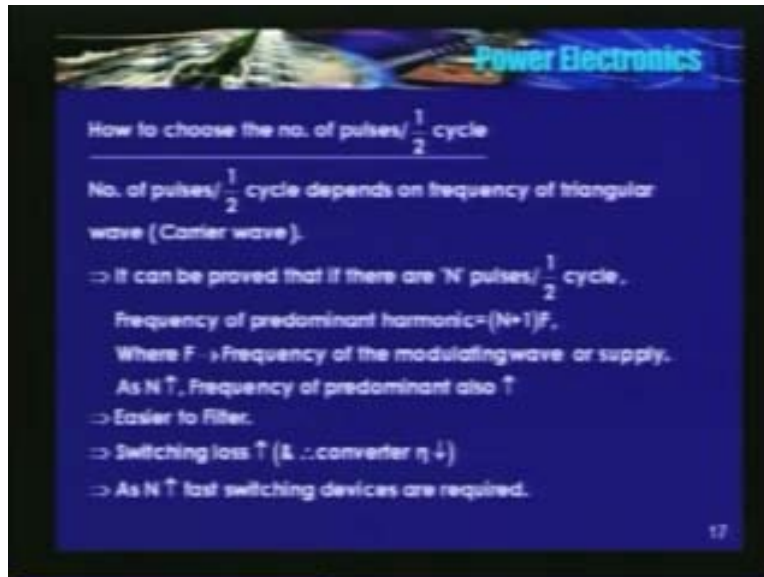

Now, how to choose the number of pulses per cycle? How to choose the number of pulses per cycle? Number of pulses per cycles depends on the frequency of the carrier or frequency of the high frequency triangular which is also known as switching frequency. The devices are switched at the frequency which is equal to the carrier frequency, remember.

In pulse width modulator inverter or converter, the devices are switched at a frequency which is equal to a carrier frequency if I use a sinusoidal PWM technique. I told you that if there are N numbers of pulses for half a cycle, frequency of the predominant harmonic is N plus 1 into the supply frequency.

So therefore, as N increases, frequency of the predominant also increases, **easier to filter**. But then as N increases, N implies the number of switching - so many times I have to turn on and off the switches. So, as N increases I have a large number of pulses. So, I need to have a really a fast switching devices.

Let me tell you one thing, IGBT may be a fast device. But then if I use it for a high power application in a high voltage application, high power, high voltage, high frequency from a device, just not possible. In principal IGBT may be a high frequency devices but then if I am using it in a high voltage circuit to transmit high power, my switching frequency comes down. I cannot operate it at a switching, at a very high frequency. It all depends on the power level, voltage level.

So, 1 criteria is I need to have a faster switching. As I switch the devices, switching losses are taking place or turn on loss and turn off loss. So, the inverter efficiency also comes down. As the loss increase the cooling effect or the heat sink requirement also increases, efficiency comes down.

So, efficiency as well as the power that is the convertor handles will determine the frequencies. In other words, I think the first criteria is the voltage and power that will deter the number of pulses. More about it we will discuss in the next class.

Thank you.