

Fundamentals of Automatic Systems
Prof. C. S. Shankar Ram
Department of Engineering Design
Indian Institute of Technology – Madras

Module No # 05
Lecture No # 22
Fuel Introduction Systems – Part 02

So by and large you know like most gasoline injection gasoline engines or SI engines or petrol engines use a MPFI system an alternative which has come up okay is what is called as gasoline direct injection okay what is called as GDI okay. So what is this Gasoline Direct Injection okay traditionally we started with carburetor then people move to MPFI engines now Gasoline Direct Injection is also popular.

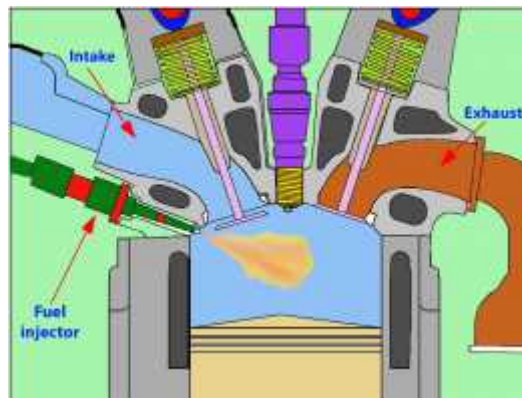

GASOLINE DIRECT INJECTION (GDI)

So what is gasoline direct injection when we compared with port injection I am going in a sequence okay so that we compare one with other. So here in a gasoline direct injections system the operating pressures increase okay now they are in the order of 10 power 2 bars okay hundreds of bars okay so what happens in a gasoline injection system or sorry gasoline direct injection system. So if we compare it with port injection we immediately observe even from the term gasoline direct injection that now the fuel is going to be directly sprayed into the engine cylinder right.

So previously we saw that the fuel was sprayed somewhere here right upstream of the intake valve now the injector is placed such that it will spray gasoline directly into the cylinder right. So that is the what to say concept behind this gasoline direct injection. So fuel is injected directly

into the cylinder when the suction stroke is in progress okay and the piston is let us say near BDC. So it is getting closer to BDC okay so when the suction stroke is progressive why higher injection pressures?

Because please note that now the volume over which the fuel has to penetrate is more see previously in carburetor or port injection it needs to be introduced in a small volume right in port injection we introduce in the intake pipe right of the intake path right. So the fuel will mix with air and go into the cylinder but here now we are injecting directly into this cylinder so the fuel jet should be sprayed like a mist and it should also penetrate into the cylinder right is it not? Because otherwise you know like the fuel will there will be a rich or locally rich pockets of fuel air mixture which will not result in good combustion right.

So higher pressures are required to enable of course compared to port injection see we are comparing to the previous cases since the fuel spray must penetrate the cylinder against the in cylinder pressure. Because previously when we are introducing the port there is already air flowing through the port right that essentially took away the fuel right in a certain sense. Here we need to spray against the in cylinder pressure and also essentially go directly into the cylinder right.

So obviously the advantages are multiple comparatively better atomization and vaporization right when we compare to port injection right and we will see that we remove wall wetting in the intake path or pipe right because we are spraying directly into the cylinder and we can have a shorter injection duration to deliver the same mass of fuel. Because with higher injection pressures the mass flow rate will be more the mass flow rate will be more in order to deliver the same mass you can have a shorter injection time right.

So those are advantages of course what is the main limitation cost and complexity increase right. So if we want these benefits so this is GDI okay gasoline direct injection okay.

So the next one that we are going to look at is the following diesel direct injection so anyway in diesel engines the combustion of the fuel happens due to self-ignition and as we have all seen in a diesel engine the injection of fuel happens towards the end of the compression stroke.

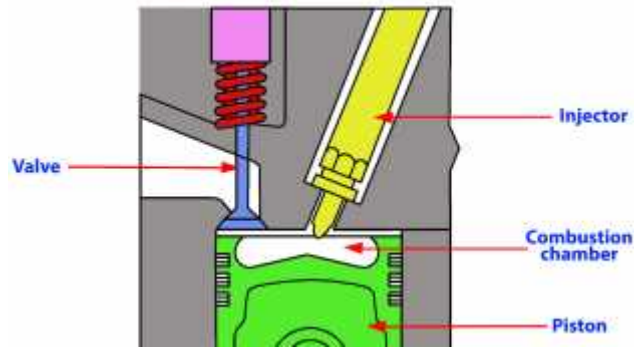

DIRECT DIESEL INJECTION

So the diesel fuel has to be sprayed against a high pressure in the cylinder and not only that it has very little time to atomize, vaporize and the formation of a homogeneous mixture.

So due to all these reasons the operating pressures are very high okay so this can be of the order of thousands of bars in a diesel direct injection engine okay. So how does this work a simple schematic is as follows so we can observe that once again the fuel is directly injected into the engine okay using this injector okay so you can see that the injector directly will spray the fuel at very high pressures please note that although the volume of the combustion chamber of the cylinder is small because the diesel is injected towards the end of compression the pressure is high.

So and the time available for the fuel to vaporize atomize and vaporize and form a combustible homogeneous mixture also small when compared with SI engines. So all these factors should be kept in mind when we design an injection system for a diesel engine right. So that is why the pressures are pretty high okay so we can observe that fuel is injected slightly before TDC as we already discussed in a previous class when we discuss the combustion process in CI engines and we have better vaporization better atomization and vaporization of course okay can use less volatile fuels such as diesel right.

Since the temperatures are also going to be high right diesel engines are going to be higher compression ratio engines okay. So we can use less volatile fuel like diesel okay which can essentially combust which can vaporize and still combust due to the high pressures and

temperatures that exist in the cylinder. So we can use less volatile fuels such as diesel due to higher cylinder pressures okay.

So essentially we have operating pressures in the range of 10 to 30 bars and this insures you know like very good vaporization right and even the rate of delivery of the fuel is also pretty high okay. So that those are the attributes of a diesel direct injection system obviously the cost and complexity are very high. So what people do what the system that is popular today in diesel engines is what is called as a common rail system.

So happens in a common rail system is that the diesel fuel is pressurized to a high pressure in what is called as a common rail okay. So and then from this rail you go to multiple cylinders let us say you have 4 cylinder to cylinder 1, 2, 3 and 4 right. So the fuel is taken to the 4 cylinders so that the pressures are pretty uniform right when we injected at very high pressures and we avoid any major pressure fluctuation right if we use a small channel right directly to pump the diesel fuel.

So this common rail acts like a high pressure local reservoir it is small capacity so that we would take from that common rail and spray it directly into the cylinder okay so that is what is called as common rail system okay use for injecting diesel. So broadly these are the few 4 fuel introduction systems okay the simple carburetor, port injection, gasoline direct injection and diesel direct injection okay so these are the 4 broad categories of the injections systems as we have seen the pressure ranges at which these injection systems operate kept on increasing as we went from one to other okay. There are both pros and cons associated with each okay.

So in order to get an insight on how this air fuel ratio can be regulated let us go and analyze the simple carburetor because as I mention at the beginning once objective of this course is also to use concepts that we have learnt in basic what to say undergraduate engineering courses right what we take in a first year or second year right to analyze various automotive system. So let us go and look at the simple carburetor and let us do an analysis of that okay.

So let us now consider what is called as a simple carburetor a basic carburetor which is used to get the appropriate fuel air mixture so let me first introduce to you the various components of this device and then we would do the analysis.

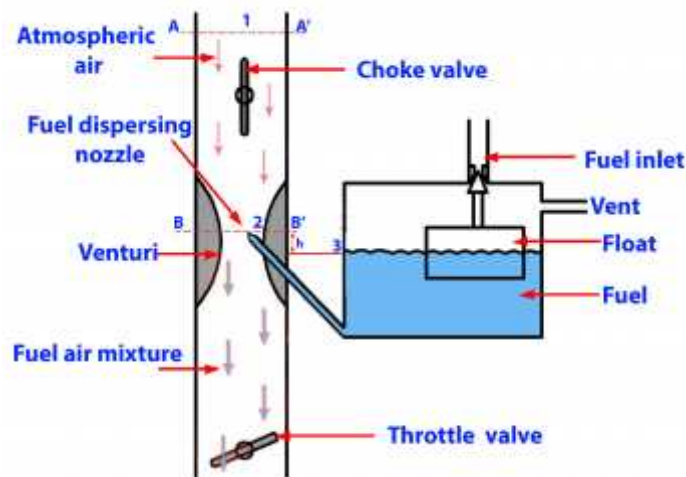

SIMPLE CARBURETOR

So this is a simple schematic of a this carburetor so we can see that air enters a carburetor okay and this is what is called as a choke valve we will come to the choke valve later on okay.

The throttle valve is downstream in the carburetor and we can see that we have a venturi so we can observe that the venturi is a reduction in the cross section of the carburetor and we have what is called as the throat of the venturi right the place where the cross sectional area is the least. Now air is coming into the carburetor and we have this which passes through the venturi as it passes through the venturi because the cross section drops the pressure drops and the speed increases okay and the speed pressure drops becomes highest at the throat section where the speed will be highest okay.

Now at the throat section we can see that what is called as the fuel dispersing nozzle okay so this nozzle tip is placed at the throat okay what is called as the fuel dispersing nozzle or a fuel discharge nozzle so that is placed at the throttle and this pipe is connected to the float chamber which is the local what to say source of fuel for the carburetor. So we see that we have a float which is connected the fuel inlet and that maintains a common sorry constant level of fuel always in the carburetor.

And the carburetor is also vented to the atmosphere okay so that the pressure at the top surface of the fuel in the carburetor is close to atmospheric pressure okay. So we can see that the throttle valve is downstream and the fuel discharge nozzle is placed at point 2 okay in the cross section B-B prime okay. The point 3 corresponds to the top surface of the fuel one can observe that there is a difference in the elevation between point 2 and point 3 you can see that the top surface of the fuel in the carburetor is placed vertically below the fuel discharge nozzle why?

That is because typically the pressure at point 2 is always lower than atmospheric most of the time if they were at the same level what will happen although the elevation is same the pressure is lower at point 2 so the fuel may bleed even when it is not necessary that is the fuel may get into the carburetor and get wasted and it may leak even when it is not required. So the level of the fuel in the float chamber is slightly below the tip of the fuel discharge nozzle to ensure that the fuel is taken from the float chamber only when there is a sufficient flow of air in the carburetor and there is a sufficient pressure drop okay.

This elevation is quantified by this parameter 'h' so this small h is used to quantify the what to say elevation difference okay between these two points okay. So these are the main components of a fuel sorry simple carburetor and this difference in pressure is what is called as carburetor depression so what is carburetor depression? It is the difference in the pressure between the top surface of the float chamber and the venturi throat okay that is what is called as carburetor depression.

Of course this pressure difference keeps on varying right as we operate the carburetor right so it depends on the pressure at point 2 right. So that is going to be what is called as carburetor depression and to avoid over flow of the fuel through the fuel discharge nozzle okay the level of fuel in the float chamber is maintained slightly lower than the tip of the fuel discharge nozzle okay. The fuel dispersing nozzle is called by someone as fuel discharge nozzle okay.

So they are used interchangeable okay so these are some important term what to say concepts okay so once again please note that the air is drawn from the atmosphere through the air intake system and it enters the venturi as it goes through the venturi there is a pressure drop and the speed of air increases due to the pressure drop at the venturi throat fuel is essentially sucked from

the float chamber depending on the amount of pressure drop and the flowing air takes the fuel from the fuel discharge nozzle atomizes it and takes it downstream okay pass the throttle valve to the intake pipe okay.

So that is what happens in this simple carburetor so the main components are this float chamber okay which contains all these subcomponents the venturi section the fuel discharge nozzle the throttle valve and the choke valve. The throttle valve is what is under the control of the driver okay so that can be opened and closed by the driver we will what to say look at how this carburetor functions in more detail in the next class by looking at the throttle valve and the choke valve in closer detail and we will also use simple concepts from thermodynamics and fluid mechanics to analyze this carburetor okay so I will stop here for this class and we continue in next class thank you.